

AccuPyc II

GAS DISPLACEMENT PYCNOMETER SERIES

M I C R O M E R I T I C S



OPERATOR MANUAL

134-42800-01
Rev -
Dec 2014

Trademarks

AccuPyc is a registered trademark of Micromeritics Instrument Corporation.

Micromeritics is a registered trademark of Micromeritics Instrument Corporation.

Scientech is a registered trademark of Scientech, Inc.

Windows is a registered trademark of Microsoft Corporation.

Copyright

The software described in this manual is furnished under a license agreement and may be used or copied only in accordance with the terms of the agreement.

WARRANTY

MICROMERITICS INSTRUMENT CORPORATION warrants for one year from the date of shipment each instrument it manufactures to be free from defects in material and workmanship impairing its usefulness under normal use and service conditions except as noted herein.

Our liability under this warranty is limited to repair, servicing and adjustment, free of charge at our plant, of any instrument or defective parts when returned prepaid to us and which our examination discloses to have been defective. The purchaser is responsible for all transportation charges involving the shipment of materials for warranty repairs. Failure of any instrument or product due to operator error, improper installation, unauthorized repair or alteration, failure of utilities, or environmental contamination will not constitute a warranty claim. The materials of construction used in MICROMERITICS instruments and other products were chosen after extensive testing and experience for their reliability and durability. However, these materials cannot be totally guaranteed against wear and / or decomposition by chemical action (corrosion) as a result of normal use.

Repair parts are warranted to be free from defects in material and workmanship for 90 days from the date of shipment.

No instrument or product shall be returned to MICROMERITICS prior to notification of alleged defect and authorization to return the instrument or product. All repairs or replacements are made subject to factory inspection of returned parts.

MICROMERITICS shall be released from all obligations under its warranty in the event repairs or modifications are made by persons other than its own authorized service personnel unless such work is authorized in writing by MICROMERITICS.

The obligations of this warranty will be limited under the following conditions:

1. Certain products sold by MICROMERITICS are the products of reputable manufacturers, sold under their respective brand names or trade names. We, therefore, make no express or implied warranty as to such products. We shall use our best efforts to obtain from the manufacturer, in accordance with his customary practice, the repair or replacement of such of his products that may prove defective in workmanship or materials. Service charges made by such manufacturer are the responsibility of the ultimate purchaser. This states our entire liability in respect to such products, except as an authorized person of MICROMERITICS may otherwise agree to in writing.
2. If an instrument or product is found defective during the warranty period, replacement parts may, at the discretion of MICROMERITICS, be sent to be installed by the purchaser, e.g., printed circuit boards, check valves, seals, etc.
3. Expendable items, e.g., sample tubes, detector source lamps, indicator lamps, fuses, valve plugs (rotor) and stems, seals and O-rings, ferrules, etc., are excluded from this warranty except for manufacturing defects. Such items which perform satisfactorily during the first 45 days after the date of shipment are assumed to be free of manufacturing defects.

Purchaser agrees to hold MICROMERITICS harmless from any patent infringement action brought against MICROMERITICS if, at the request of the purchaser, MICROMERITICS modifies a standard product or manufactures a special product to the purchaser's specifications.

MICROMERITICS shall not be liable for consequential or other type damages resulting from the use of any of its products other than the liability stated above. This warranty is in lieu of all other warranties, express or implied, including but not limited to, the implied warranties of merchantability or fitness for use.

CONTACT US

Micromeritics Instrument Corporation

4356 Communications Drive

Norcross, GA / USA / 30093-2901

Phone: 1-770-662-3636

Fax: 1-770-662-3696

www.Micromeritics.com

U.S. Inquiries

U.S. Sales Phone: 1-770-662-3636

USSales@Micromeritics.com

Quotes, Orders, and Customer Satisfaction

Customer Service Phone: 1-770-662-3636

Orders@Micromeritics.com

U.S. Instrument Service Department

U.S. Service Department Phone: 1-770-662-3666

ABOUT THIS MANUAL

The following formats are used throughout this manual:



NOTE - Notes contain important information pertinent to the subject matter.



CAUTION - Cautions contain information to help prevent actions that may damage the analyzer or components.



WARNING - Warnings contain information to help prevent actions that may cause personal injury.

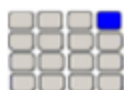

Keypad Function - The keypad icon indicates the section is applicable only when using the keypad.

Field Labels and Screen Titles

Labels and Buttons	Description
Buttons (in the application)	Buttons in the application are represented as bold font and blue letters — such as: Save , Edit , and Replace All .
<i>Field Labels</i>	Field Labels are represented as italicized words — such as: <i>Sample</i> , <i>Automatically Collected</i> , and <i>Analysis Conditions</i> .
Keyboard Commands	Keyboard commands are represented as bold font and black letters — such as: F2 and Alt+F4 .
Menu Instructions	Menu instructions are represented as bold and italicized words — such as: File > New Sample and Reports > Start Report .
<i>Screen Tabs</i>	Screen Tabs are represented as italicized words — such as: <i>Sample Description</i> , <i>Analysis Conditions</i> , and <i>Report Options</i> .
<i>Screen Titles</i>	Screen Titles are represented as italicized words — such as: <i>Analysis Adsorptive Properties</i> , <i>Free Space</i> , and <i>Sample Tube</i> .

Blank Page

Table of Contents

Warranty	<i>i</i>
Contact Us	<i>ii</i>
About this Manual	<i>iii</i>
1 About the AccuPyc II 1340 Pycnometer	<i>1 - 1</i>
About the TEC Module	<i>1 - 2</i>
Asphalt Density Application	<i>1 - 2</i>
About the FoamPyc Module	<i>1 - 3</i>
Instrument Components	<i>1 - 4</i>
Front	<i>1 - 4</i>
Rear	<i>1 - 5</i>
About the Software	<i>1 - 6</i>
Equipment Options	<i>1 - 7</i>
High Pressure Core Pycnometer	<i>1 - 7</i>
Large Volume Core Pycnometer	<i>1 - 7</i>
MultiVolume Inserts	<i>1 - 7</i>
Multigas Option	<i>1 - 7</i>
Configuration Options	<i>1 - 8</i>
Glove Box	<i>1 - 8</i>
Temperature Controlled Module	<i>1 - 9</i>
Specifications	<i>1 - 10</i>
Power the Analyzer On and Off	<i>1 - 12</i>
2 Data Entry with Keypad	<i>2 - 1</i>
About the Display	<i>2 - 1</i>
About the Keypad	<i>2 - 2</i>
Cancel an Analysis	<i>2 - 5</i>
Manual Mode	<i>2 - 5</i>
Transmit	<i>2 - 6</i>
Analysis Parameters	<i>2 - 7</i>

Setup Reports	2 - 9
Review Data	2 - 11
View Data Results	2 - 13
Print a File	2 - 13
3 About the Software	3 - 1
Menu Structure	3 - 1
Common Fields and Buttons	3 - 2
Option Presentation	3 - 5
File Status, Description, Extension, and Location	3 - 6
Application Shortcuts	3 - 7
Menu Shortcuts	3 - 7
Keyboard Shortcuts	3 - 7
Sample Defaults	3 - 8
Edit a Sample Default File	3 - 8
Analyzer Status	3 - 8
Show Instrument Log	3 - 8
Show Instrument Schematic	3 - 9
Show Status	3 - 10
Print, List, or Export Files	3 - 11
Open a File	3 - 12
Uninstall the Software	3 - 13
Installing Analyzer Software Upgrade	3 - 14
4 About Sample Files	4 - 1
Create Sample Files	4 - 2
Create Sample Files using Advanced Presentation Option	4 - 2
Create Sample Files using Basic or Restricted Presentation Option	4 - 4
Sample Cup	4 - 5
Material Parameters	4 - 6
5 About Parameter Files	5 - 1
Parameter Files Directory	5 - 1

Analysis Conditions	5 - 2
FoamPyc Application	5 - 4
Report Options	5 - 5
Collected Data	5 - 7
6 Perform an Analysis	6 - 1
Preparing and Loading Sample	6 - 1
FoamPyc Methods	6 - 1
Standard Method	6 - 1
Start an Analysis	6 - 3
Start an Analysis using the Software	6 - 3
Start an Analysis using the Keypad	6 - 4
QuickStart Analysis	6 - 6
Sequence Analysis	6 - 8
Review Analysis	6 - 9
7 About Reports	7 - 1
Open and Close Reports	7 - 1
Start Reports	7 - 1
SPC Report	7 - 2
Regression Report	7 - 2
Control Chart Report	7 - 5
Report Features and Shortcuts	7 - 9
Report Header Shortcuts	7 - 10
Report Toolbar	7 - 11
Graph Features and Shortcuts	7 - 13
Tabular Report Features and Shortcuts	7 - 19
Graph Overlays	7 - 20
Generating Graph Overlays	7 - 20
Generate Multiple Sample Overlays	7 - 21
Generate Multiple Graph Overlays	7 - 22
Report Examples	7 - 24
Combined Report	7 - 24

Summary Report Example	7 - 25
Tabular Report Example	7 - 26
Graph Report Example	7 - 27
Overlay Report Example	7 - 28
Equilibration Report Example	7 - 29
Sample Log Example	7 - 30
8 Selected Reports	8 - 1
Combined Report	8 - 1
Density and Volume Table	8 - 1
Density vs Cycle Number Trend Plot	8 - 2
Density vs Time Trend Plot	8 - 3
Equilibration Report	8 - 4
Options Report	8 - 5
Pressure and Volume Table	8 - 5
Sample Log Report	8 - 5
Summary Report	8 - 6
Tabular Report	8 - 6
Total Pore Volume vs Temperature	8 - 7
Volume vs Cycle Number Trend Plot	8 - 8
9 Diagnostics using the Software	9 - 1
10 Calibration	10 - 1
Calibrate using the Software	10 - 1
Calibration Report	10 - 1
Calibrate Temperature Offset	10 - 2
Calibrate Zero Cell Volume	10 - 2
Calibrate Zero Pressure	10 - 4
Reset Pressure Calibration	10 - 5
Calibrate Volume Scale	10 - 6
Verify Operation	10 - 10
Load Calibration from File	10 - 12

Save Calibration to File	10 - 13
Calibrate using the Keypad	10 - 14
Calibrate Function	10 - 14
Calibration Data	10 - 14
Calibrate Volume	10 - 15
Reset Pressure Calibration	10 - 16
Review Calibration	10 - 17
Temperature	10 - 19
Zero the Pressure Transducer & Chamber Volume	10 - 19
Load Calibration Data from a USB Stick	10 - 20
Copy Calibration Data to a USB Stick	10 - 20
11 Hardware Components and Accessory Installation	11 - 1
Add Analysis Module to Control Module	11 - 1
Configure an Analytical Balance	11 - 3
Printer Setup	11 - 3
12 Maintenance and Troubleshooting	12 - 1
Chamber Cap O-Ring	12 - 4
Grease the Chamber Cap O-Ring	12 - 4
Replace the Chamber Cap O-Ring	12 - 4
Check the Cell and Expansion Chambers for Leaks	12 - 6
Check for Leaks using the Software	12 - 6
Check for Leaks using the Keypad	12 - 8
Clean the Dust Filter	12 - 9
Clean the Pycnometer	12 - 10
Recover From a Power Failure	12 - 10
Reset the Pycnometer	12 - 11
Guidelines for Connecting Gases	12 - 11
Replace a Gas Cylinder	12 - 12
Set Regulator Pressure	12 - 14
Set Regulator Pressure with the Software	12 - 14
Set Regulator Pressure with the Keypad	12 - 15

13 Parts and Accessories	13 - 1
A Error Messages	A - 1
Error Messages for 1340 AccuPyc Keypad Only	A - 19
B Calculations	B - 1
Analysis	B - 1
10, 100, and 350 cm ³ Units	B - 1
1 cm ³ and 2000 cm ³ Units	B - 1
Calculations for FoamPyc Methods	B - 2
Method A: Computed Open Cell Fraction	B - 2
Method B: Measured Open Cell Fraction	B - 2
Method C: Uncorrected Open Cell Fraction	B - 3
Method D: Compressibility Test	B - 3
Method E: Fracture Test	B - 3
Calibration	B - 4
Volume Offset	B - 4
Volume Scale	B - 4
Geometric Volume and Active Area	B - 5
Cube	B - 5
Cylinder	B - 5
Rectangle	B - 5
Run Precision	B - 6
Total Pore Volume	B - 6
Total Solids Concentration	B - 7
SPC Report Variables	B - 8
Regression Chart	B - 8
Control Chart	B - 9
Resin Volume	B - 10
Percent Porosity	B - 10
Specific Gravity	B - 10
Asphalt Density Calculations	B - 11

C Sample Volume Equation Derivation	C - 1
10, 100, and 350 cm ³ Units	C - 1
1 cm ³ and 2000 cm ³ Units	C - 3
D Transmitted Data	D - 1
Analysis Report	D - 1
Calibration Report	D - 3
E RS-232 Pin Assignment	E - 1
F Temperature Controlled AccuPyc	F - 1
Attach a Circulating Bath	F - 1
Add Analysis Modules to a Temperature Controlled Module	F - 1
G MultiVolume Insert Option	G - 1
Operating Parameters	G - 1
About Inserts and Sample Cups	G - 2
Install and Remove Inserts and Sample Cups	G - 3
Calibrate Insert	G - 5
0.1 cm ³ Insert	G - 5
1, 10, 3.5, 35, 650, and 1300 cm ³ Inserts	G - 6
H TEC Module	H - 1
Set the TEC Temperature	H - 1
Operate the TEC Module	H - 2
Volume Change with Temperature for the 10 cm ³ AccuPyc	H - 2
Volume Change with Temperature for the 100 cm ³ AccuPyc	H - 3
Asphalt Density Measurement	H - 4
I Multigas Option	I - 1
Install the Multigas Assembly	I - 1
Connect Gases	I - 2
Select Gases	I - 2

J Installation Instructions	J - 1
Handling System Components	J - 1
Calibration Standard	J - 1
Sample Chamber Cap	J - 1
Gas Requirements	J - 1
Pycnometer Set up	J - 2
Pycnometer Configuration	J - 2
Set the TEC Temperature	J - 4
Temperature Controlled Module Hardware Setup	J - 5
Chamber Cap O-ring	J - 5
Connect Keyboard	J - 6
Connect an Analytical Balance	J - 6
Gas Connection	J - 6
Connect the Analyzer to the Computer	J - 9
Connect an Ethernet Switch	J - 9
Brightness Control	J - 9
Configure the Pycnometer	J - 10
Configure the Pycnometer using the Keypad	J - 10
Software Installation	J - 15
Start the Application	J - 19
Specify Unit Selections	J - 19
Configure an Analytical Balance	J - 20
Reinstall or Modify the Software	J - 21
Uninstall the Software	J - 22
Index	Index - 1

1 ABOUT THE ACCUPYC II 1340 PYCNOMETER



The AccuPyc II Pycnometer is an easy to use, fully automatic gas displacement pycnometer. It determines density and volume by measuring the pressure change of helium within calibrated volumes. It also reports the chamber temperature at the end of the requested cycles. The AccuPyc II can be operated using the analysis program installed on an attached computer, or if no computer is attached to the pycnometer, the keypad can be used to start and run analyses. The analyzer may be operated in English, French, German, Italian, or Spanish.

The AccuPyc II Pycnometer consists of a control module and an analysis module. When ordering a single unit, the control module is built into the same unit as the analysis module for convenience. The analysis modules are also available in a standalone configuration, allowing multiple analysis modules to be attached to a single controlling unit. A maximum of five analysis modules can be installed to one controller (six total). Each module has its own gas connection. The pycnometer can be controlled by either:

- a Windows interface. The operational status of the pycnometer can be continually monitored in a status window shown on the computer monitor. If the Windows interface is used, the keypad is disabled.
- the keypad if not running the Windows interface. A separate keyboard and printer can be attached to the pycnometer using USB ports.

ABOUT THE TEC MODULE



Density measurements at specific temperatures are required for certain applications. The AccuPyc II Thermo Electric Cooling (TEC) Module maintains an accurate temperature control during analysis using the principle of Peltier cooling.

TEC Modules, also known as Peltier coolers, are solid-state heat pumps that utilize the Peltier effect to move heat. By passing a current through the TEC Module, heat is transferred from one side of the module to the other, typically producing a heat differential of approximately 40° C.

The transferred heat is then removed from the system through the combination of a heat sink and fan, cooling the system to maintain a set temperature for accurate analysis.

TEC systems feature:

- fast dynamic response
- long-life
- no moving parts
- no use of refrigerants or circulated liquids/antifreeze

ASPHALT DENSITY APPLICATION

The AccuPyc II TEC Module can measure asphalt density using disposable cups to limit cross-contamination of samples. See [*"Asphalt Density Measurement" on page H - 4.*](#)

This solution can be closely correlated (<0.15% difference) to results obtained with ASTM Test Method D70-09. The AccuPyc asphalt density measurement is completed much faster than the ASTM method while virtually eliminating operator error. The Peltier thermoelectric cooling control (15 to 36 °C) provides stability for handling of samples.

Performing an asphalt density measurement requires the AccuPyc II Asphalt software and disposable sample cups. Refer to [*"Parts and Accessories" on page 13 - 1*](#) for ordering information.

ABOUT THE FOAMPYC MODULE

A FoamPyc option for measuring open and closed cell foam materials is available for both standard and temperature controlled pycnometers. This unit can be ordered initially with the FoamPyc application installed, or can be upgraded from the standard AccuPyc with a software enhancement via USB media. Configuration options are:

- 100 cm³ nominal cell volume (recommended)
- 10 cm³ nominal cell volume

The FoamPyc option performs analyses on materials such as polystyrene, urethane, and rubber foams using five different methods:

- **Method A.** Measures the closed cell fraction and corrects for the cells damaged while cutting the sample to the necessary size and shape. This is accomplished by using either the average cell diameter or the cell chord length (as defined in ASTM method D-3576) and the measurements of the sample to determine the volume of the cut cells. This volume is deducted from the total volume of the open cells measured by the pycnometer.
- **Method B.** Corrects for the cut cells by using two separate measurements. For the 2nd measurement, the sample is recut to double the amount of cut surface. The observed difference in cut open cell volume is applied as a correction to the initial measured volume. This method offers the distinct advantage that no assumptions are needed about the relative amounts of open and closed cells.
- **Method C.** Does not correct for cut cells. It is used for materials with predominantly open cells where good accuracy can be achieved without correction. The accuracy level deteriorates as the percentage of closed cells increases.
- **Method D.** Is a compressibility test. The fill pressure is increased incrementally over the sample with each repeat of the P1,P2¹⁾ cycle. The apparent variation of the measured sample volume with the average pressure is determined. This test is an approximate indication. It is not intended to be an exact measure of the volume compressibility.
- **Method E.** Is a cell fracture test; a perfectly rigid foam is assumed. First, a P1,P2 cycle is performed at the lower of two specified P1 pressures, and the results stored. A second cycle is performed at a higher specified value of P1, then a third cycle identical to the first cycle is performed. The difference between the volume of the sample on the first measurement and on the third measurement is reported as the volume of fractured cells. It is assumed that cells fracture by exposure to the highest pressure (2nd cycle) so that when the third measurement is made, the measured sample volume has decreased from the first cycle by the amount of the closed cell volume which was fractured.

¹⁾ Where P1 is the initial pressure to which the sample is charged, and P2 the final pressure after expansion.

The 100 cm³ AccuPyc II has been designed and tested to follow the procedure in ASTM Method D 6226 for FoamPyc analyses. The 10 cm³ and 350 cm³ units can be used for some types of foam materials; however, analyses on these AccuPycs will not conform to the ASTM method. The 1 cm³ AccuPyc II cannot be used to perform FoamPyc analyses.

The FoamPyc software also provides the capability to perform analyses in the *Standard* mode of operation. This is especially convenient for users who have upgraded to the FoamPyc method from the standard method. For example, a 100 cm³ AccuPyc on which FoamPyc analyses are performed and a 1 cm³ analysis module attached on which standard analyses are performed.

INSTRUMENT COMPONENTS

FRONT

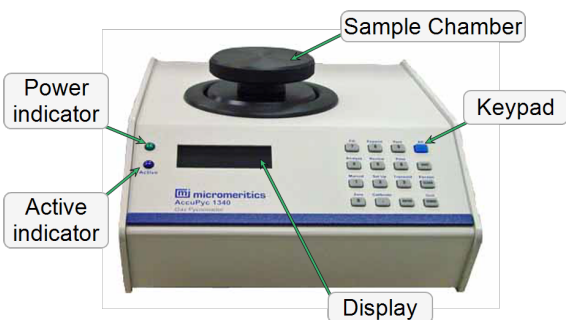

The sample chamber, located on the top panel, is where the sample container is placed for analysis, or the standard for calibration.

The sample chamber should remain capped except when inserting or removing a sample. When left uncapped, water vapor adsorbs on the inner surface of the chamber or the chamber temperature becomes unstable; either condition can affect analysis results. If water vapor accumulates in the chamber, the pycnometer must be purged.

The standalone control module, often used for the Glove Box pycnometer, does not contain a sample chamber.

Component	Description
Active indicator	A blue LED which illuminates when an operation is in progress. It is included on all analysis modules. It is not included on standalone control modules.
Display window	Displays <i>Remote Operation</i> when the Windows application is being used. The AccuPyc can be operated in the keypad mode when the Windows application is closed.
Keypad	Not used with AccuPyc software application.
Power indicator	A green LED which illuminates when the analyzer is powered on.

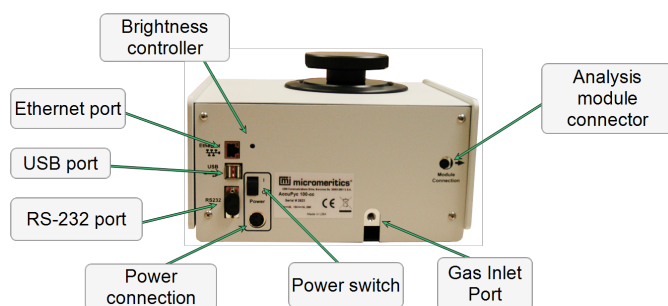
REAR

Component	Description
Analysis module connector	Used to connect up to five analysis modules to the initial control / analysis module. Each module contains analysis module input and output connectors.
Brightness control	Used to adjust the brightness of the display. See "Brightness Control" on page J - 9 .
Dust filter (not shown)	(For 2000 cm ³ units only.) Traps sample dust to protect internal valves.
Ethernet port	Provides for setting up for e-mailing reports, sending data to a web browser, or interfacing with the AccuPyc Windows application.
Gas inlet port	Use to connect the analysis gas; helium is recommended. If multiple analysis modules are attached, each module contains a gas inlet port. Multiple gases can be attached using the Multigas option. See "Multigas Option" on page I - 1 .
On/Off switch	For powering the analyzer on and off.
Power connector	For connecting the power source to the instrument.
RS-232 port	Used to transmit data only when using the keypad function.
USB connectors	Use for connecting a keyboard, printer, or balance to the instrument.

ABOUT THE SOFTWARE

The AccuPyc II Pycnometer's unique *run precision* reports data from five consecutive runs that are within a user-specified tolerance. This feature allows early termination of analyses, thereby decreasing the number of runs needed for accurate results.

Analysis provides the measurement of sample volume, from which density can be derived automatically if the sample mass is entered. The unit comes preprogrammed with default conditions and ready to perform analyses. It can be reprogrammed to meet specific needs. Analyses can be modified by entering the number of purges and purge fill pressure, number of cycles and cycle fill pressure, equilibration rate, and run precision. Modifying these parameters allow control of the primary portions of the analysis; purge and run.

When the PC software is not running, the AccuPyc II can be operated in keypad mode. For example; if the computer is inoperative for some reason, analyses can be performed using the keypad.

If running the FoamPyc module, an option to select a Standard method is available so that analyses on other types of sample materials can be performed.

Hardware and software installation instructions are found in [*"Installation Instructions" on page J - 1.*](#)

EQUIPMENT OPTIONS

HIGH PRESSURE CORE PYCNOMETER

Gas pycnometry is recognized as one of the most reliable techniques for obtaining skeletal volume and density. The fully automatic AccuPyc High Pressure pycnometer provides high speed, high precision volume measurements and density determinations on intact or crushed shale core samples.

The high pressure pycnometer:

- Operates at a pressure of 500 psi to provide a better diffusion of the gas into the rock.
- Has a stainless steel sample chamber with a volume of 100 cm³.
- Has a sample chamber that can accommodate a 48 mm (1.85 in.) diameter core of up to 60 mm (2.40 in.) in length.

LARGE VOLUME CORE PYCNOMETER

The AccuPyc Large Volume pycnometer sample chamber addresses the specific needs of operations that require pore volume knowledge of intact drilling cores. This instrument eliminates the need to break core samples into smaller pieces prior to analysis.

The large volume pycnometer:

- Has a large sample chamber with a volume of approximately 2000 cm³.
- Has a sample chamber that can accommodate a 95 mm (3.74 in.) diameter core of up to 278 mm (10.9 in.) in length.

MULTIVOLUME INSERTS

The MultiVolume option is used to analyze smaller sized samples. Options are:

- 1 cm³ nominal cell volume; contains a 0.1 cm³ cup
- 10 cm³ nominal cell volume; contains 1 cm³ and a 3.5 cm³ cups
- 100 cm³ nominal cell volume; contains 10 cm³ and 35 cm³ cups
- 2000 cm³ nominal cell volume, contains 650 cm³ and 1300 cm³ cups

Each kit includes inserts, reference standards, and sample cups. See ["Parts and Accessories" on page 13 - 1.](#)

MULTIGAS OPTION

The Multigas Option allows connection of up to four gases to one analyzer. See ["Multigas Option" on page I - 1](#) and ["Parts and Accessories" on page 13 - 1.](#)

CONFIGURATION OPTIONS

For best fit with a sample, the AccuPyc II is available in multiple configurations.



All sample chamber volumes are nominal unless otherwise specified.

- 1 cm³ sample chamber
- 10 cm³ sample chamber
- 100 cm³ sample chamber
- 350 cm³ sample chamber
- 2000 cm³ sample chamber

Best fit means the sample nearly fills the sample chamber and, therefore, optimizes the precision of the results.

GLOVE BOX

Provides for analysis of samples in which a controlled environment is required.

Options	Description
Configuration	<ul style="list-style-type: none"> • 1 cm³ sample chamber • 10 cm³ sample chamber • 100 cm³ sample chamber • 350 cm³ sample chamber • 2000 cm³ sample chamber

This unit consists of two separate modules. The controller is placed outside the glove box, while the analysis module is placed inside the glove box. Up to six analysis modules may be placed in the glove box, all controlled by one external control module.

TEMPERATURE CONTROLLED MODULE

Provides for the attachment of an external circulating bath.

Options	Description
Configuration	<ul style="list-style-type: none">• 10 cm³ sample chamber• 100 cm³ sample chamber

The temperature controlled unit is specifically designed for temperature sensitive materials. This unit is ideally suited for laboratories in which ambient temperature varies during normal work hours, or in which subambient cooling is required.

SPECIFICATIONS

Characteristic	Specification
Analysis	
Precision	Reproducibility typically to within $\pm 0.01\%$ of the nominal full scale cell chamber volume. Reproducibility guaranteed to within $\pm 0.02\%$ of the nominal full scale volume on clean, dry, thermally equilibrated samples using helium in the 15° to 35 °C range (15° to 50 °C for temperature controlled models).
Accuracy	Accurate to within 0.03% of reading, plus 0.03% of sample capacity
Electrical	
Voltage	90 to 264 VAC
Power	30 VA
Frequency	50 to 60 Hz
Environment	
Temperature	Stable between 15° and 35 °C (59° to 96 °F) Temperature controlled AccuPyc - temperature stability is dependent upon specifications of the installed circulator. Recommended range: 15° to 50 °C (59° to 122 °F)
Humidity	20 to 80% relative, non-condensing
Gases	
Research grade helium or nitrogen is recommended. If unavailable, use helium with a dew point of -67 °C (-88 °F) or lower. Carbon dioxide, dry air, or argon can also be used for different applications. A multigas option is available for connection of multiple gases.	
Physical	
Analysis Module (1, 10, 100 cm³)	Height. 17.9 cm (7.0 in.) Width. 22.2 cm (8.7 in.) Weight. 7.9 kg (17.4 lbs) Depth. 36.2 cm (14.3 in.)
Analysis Module (350 cm³)	Height. 25.9 cm (10.2 in.) Width. 22.2 cm (8.7 in.) Weight. 10.5 kg (23.2 lbs) Depth. 36.2 cm (14.3 in.)
Analysis Module (2000 cm³)	Height. 43 cm (17 in.) Width. 27 cm (10.6 in.) Weight. 26 kg (57.0 lbs) Depth. 36.2 cm (14.3 in.)

Characteristic	Specification
Control Module	Height. 17.9 cm (7.0 in.) Width. 27.3 cm (10.7 in.) Weight. 3.6 kg (8.0 lbs) Depth. 36.2 cm (14.3 in.)
Control Analysis Module	Height. 17.9 cm (7.0 in.) Width. 27.3 cm (10.7 in.) Weight. 9.3 kg (20.5 lbs) Depth. 36.2 cm (14.3 in.)
TEC Module	Height. 27.3 cm (10.7 in.) Width. 28.7 cm (11.3 in.) Weight. 13.8 kg (30.5 lbs) Depth. 36.1 cm (14.2 in.)
Printers	
Requirements:	<ul style="list-style-type: none"> • must be USB 2.00 (or newer) • must have a printer language supported by one of the printer drivers • cannot be host based
Supported printers	<ul style="list-style-type: none"> • Canon Bubble Jet • Epson ESCP • Epson ESCP Raster • Epson ESCP2 • HP PCL 3 • HP PL 6XL • Postscript
Sample Chamber	
1 cm³ chamber	1.15 cm ID × 1.1 cm Deep (0.45 in. ID × 0.44 in. Deep)
10 cm³ chamber	1.8 cm ID × 3.93 cm Deep (0.72 in. ID × 1.55 in. Deep)
100 cm³ chamber	4.62 cm ID × 6.17 cm Deep (1.82 in. ID × 0.2.43 in. Deep)
350 cm³ chamber	5.84 cm ID × 13.94 cm Deep (2.30 in. ID × 5.49 in. Deep)
2000 cm³ chamber	9.7 cm ID × 26 cm Deep (3.8 in. ID × 10.2 in. Deep)
Computer Requirements	
<p>Windows 7 Professional or higher operating system is recommended for the best user experience. If the computer is to be connected to a network, a second Ethernet port on the computer must be used for that purpose.</p>	
	<p>All users of the application will need Read / Write permission to all directories and subdirectories where the application is installed.</p>
<p><i>In keeping with a policy of ongoing product improvement, specifications are subject to change without notice.</i></p>	

POWER THE ANALYZER ON AND OFF



It is important that a constant temperature be maintained inside the unit because a change in temperature could alter analysis results. We recommend that the pycnometer remain powered on at all times to maintain thermal stability.



Do not turn off the analyzer while initialization is in progress. Doing so may damage the instrument.

When the analyzer is powered on, after a few seconds, the system vents automatically and the green indicator light on the front panel illuminates. Allow approximately 30 minutes for the analyzer to warm before performing analyses. For analyses that require very precise results, allow the analyzer to warm a minimum of two hours. If running the analyzer with a computer:

- **Power ON.** Power on the equipment in the following order:
 - Computer
 - Monitor
 - Printer
 - Analyzer
 - Start software application

- **Power OFF.** Power off the equipment in the following order:
 - Analyzer. Allow any analyses in progress to complete prior to powering off.
 - Software application. Always exit the analysis program before powering off. Failure to do so could result in loss of data.
 - Computer
 - Monitor
 - Printer

If running the analyzer without a computer:

- **Power ON**
 - Analyzer.

- **Power OFF.** Power off the equipment in the following order:
 - Allow any analyses in progress to complete prior to powering off the analyzer.
 - Printer
 - Analyzer

2 DATA ENTRY WITH KEYPAD

Data can be entered into the system using either a:

- **Keypad (or a keyboard).** Used if a computer with the analyzer software installed is not connected to the analyzer. In this case, any section of this manual referring to software can be omitted. All instructions specific to the keypad are designated with the icon specified in the section ["About this Manual" on page iii](#).
- **Computer.** Used if the computer with analysis software is installed and connected to the analysis module. In this case, this section of this manual can be skipped.

ABOUT THE DISPLAY

The display provides information about the analyzer and the current operation. During operations, different types of information are shown in lines two, three, and four. Line one always displays the unit and serial number. If the **Alt** key is pressed, the 3 in 10 cm³ will change to a + (plus sign). This is an example of the display when the analyzer is in an idle state, or the *Reload* prompt.

Unit[n]>	SN 1234>	10 cm ³
	X - X - X	
Reload		
P = (current pressure)		

Line	Description
First	Displays the unit number, serial number, and nominal cell volume of the selected unit. Up to five analysis modules may be attached; though the initial module, containing the keypad and display, will control all units.
Second	At the <i>Reload</i> prompt, manual control, or an automatic operation, this line contains three characters, separated with dashes. The first character represents the <i>Fill</i> valve, the second represents the <i>Expand</i> valve, and the third represents the <i>Vent</i> valve. Valve states: X = Closed, O = Open During user interface, this line shows the command currently in use.
Third	Displays status of the current operation, or <i>Reload</i> when in an idle state. When the <i>Reload</i> prompt is displayed, this line may also contain an asterisk (*), indicating there is a message in the queue. Refer to "Error Messages" on page A - 1 . During certain functions (such as <i>Setup</i>), this line contains a prompt for additional information.

Line	Description
Fourth	<p>At the <i>Reload</i> prompt, shows the current pressure and temperature alternately, where:</p> <ul style="list-style-type: none"> • P = Pressure • T = Temperature <p>This line is also used to choose options, enter information, or provide information about the current operation.</p>

ABOUT THE KEYPAD



A keyboard can be connected to the USB port on the rear panel of the AccuPyc II. Commands can be entered from either the keypad or the keyboard.

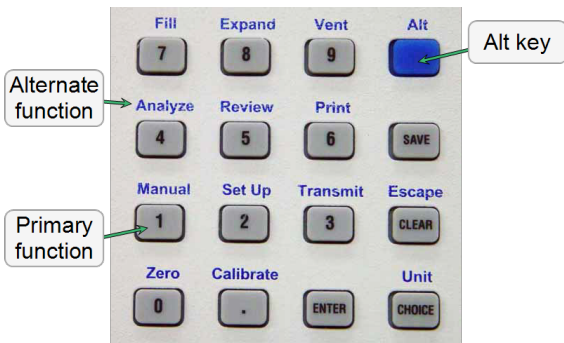

Most keys on the keypad perform one primary and one alternate function. The primary function of any key is indicated by the number or command on the face of the key. The alternate function is indicated by the command above the key. The top right corner of the display screen will show a + (plus sign) when the **Alt** key is pressed and the alternate function mode is entered. See ["About the Display" on the previous page](#).

To select the:

- **Primary function.** Press only the key. Primary functions are labeled on the key face. For example; press **4** to enter the number 4.
- **Alternate function.** Press **Alt**, then press the key. Alternate functions have blue labels above the key. For example; press **Alt + 4** to start an analysis. If the **Alt** key is pressed accidentally, pressing it a second time will cancel its function.

The alternate functions for keys **7** (FILL), **8** (EXPAND), and **9** (VENT) are executed differently. Press **Alt + 1** first to enter Manual mode then press the alternate key. For example: press **Alt + 1 + 7** to manually control the Fill valve. Press **Alt + CLEAR** to exit Manual mode.

Functions can be entered from the keyboard.

Keypad and Keyboard Functions

Keypad Function	Key Sequences		Description
	Keypad	Keyboard	
Decimal (.)	.	.	Enter a decimal point, a dash for sample or instrument ID, a slash for date, or a colon for time
Number keys (0 through 9)	0 - 9	0 - 9	Enters the numbers 0 through 9
Calibrate	Alt + . (decimal)	Ctrl + O	Calibrates the pycnometer.
Zero	Alt + 0	Ctrl + Z	Zeroes the pressure transducer.
Manual	Alt + 1	Ctrl + Y	<p>Provides manual control to open and close valves.</p> <ul style="list-style-type: none"> • Fill (Key 7) • Expand (Key 8) • Vent (Key 9) <div style="border: 1px solid black; padding: 5px; margin: 10px 0;"> <pre>Unit[n]> SN 1234> 10 cm3 X - X - X Reload P = (current pressure)</pre> </div> <p>The state of the valve is shown on the second line of the display, where X=Closed and O=Open.</p> <p>Alt + CLEAR exits manual mode.</p>
Set Up	Alt + 2	Ctrl + U	<p>Display or edit:</p> <ul style="list-style-type: none"> • Analysis parameters • Report options • Calibration data • Data transmission parameters • Unit types • Operating language • Date and time

Keypad and Keyboard Functions (continued)

Keypad Function	Key Sequences		Description
	Keypad	Keyboard	
Transmit	Alt + 3	Ctrl + T	Transmits analysis or calibration data. Transmits a partial report if an automatic operation is in progress.
Analyze	Alt + 4	Ctrl + A	Performs an analysis.
Review	Alt + 5	Ctrl + R	Review completed analysis or calibration data.
Print	Alt + 6	Ctrl + P	Prints an analysis or calibration report. If an automatic operation is in progress, prints a partial report.
Unit	Alt + CHOICE + (unit number)	N/A	Selects unit (when multiple analysis modules are attached).
Escape	Alt + CLEAR	Esc	Discards all data entered in the current mode and returns to display mode. Cancels an automatic operation in progress. Exits manual mode.
CHOICE	CHOICE	Ctrl + N	Display the next message when in display mode. Display the next multiple choice item when in command mode.
CLEAR	CLEAR	Ctrl + X	Clear a message when in display mode. Clear an entry when in command mode.
ENTER	ENTER	Enter or Ctrl + M	Complete an entry or begin an action.
SAVE	SAVE	Ctrl + W	Save the information and return to display mode.

CANCEL AN ANALYSIS

To cancel an analysis, press **Alt + CLEAR**.

```
Unit[n]>   SN1234>   10 cm3
Analyze
[Enter] to cancel
automatic operation
```

Press **ENTER** within five seconds to cancel the operation. A notification that the automatic operation has been canceled will be displayed.

When canceling an operation, messages are displayed indicating that termination is in progress. The termination process, which vents the system, takes about 30 seconds and returns to the *Reload* prompt.

To view the data that have been collected, press **CHOICE**.

The following prompt is displayed if no cycles have been completed.

```
Unit[n]>   SN1234>   10 cm3
          X - X - X
DTA_ERR:
No data to compute
```

MANUAL MODE

Press **Alt + 1** to enter manual mode, allowing manual control of the Bypass, Fill, Expansion, and Vent valves.

```
Unit[n]>   SN1234>   10 cm3
          X - X - X
Manual
p = (pressure)
```

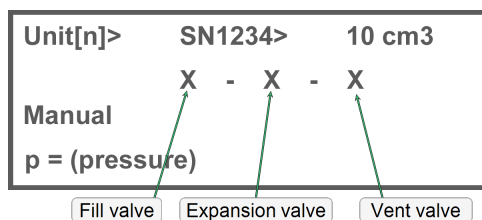

The Bypass valve is only available on the 2000 cm³ units and the High Pressure Core Pycnometer units.

Display Text	Description
Manual	<p>When Manual is shown, manually open and close the Fill, Expansion, and Vent valves by pressing:</p> <ul style="list-style-type: none"> • 5 - Opens and closes the Bypass valve • 7 - Opens and closes the Fill valve • 8 - Opens and closes the Expansion valve • 9 - Opens and closes the Vent valve <p>The three characters in the second line of the display show the state of the valves (Fill, Expansion, Vent). X = Closed. O = Open.</p> <p>Press SAVE to exit Manual mode and return to display mode.</p>



Prolonged opening of all three valves at one time may cause excessive loss of helium.

TRANSMIT

The AccuPyc RS-232 interface transmits report data to a computer using the standard ASCII file format. Reports may be transmitted in a single column format or a spreadsheet format. See ["*Transmitted Data*" on page D - 1](#).

Press **Alt + 3** to transmit report data.

Press **Alt + CLEAR** to cancel report data transmission.

ANALYSIS PARAMETERS

This option enables specific analysis and calibration parameters. Although the *Setup Type* is shown as *Analysis Parameters*, these same prompts are used to specify calibration parameters. The pycnometer is shipped with default values; however, these settings may be modified to meet laboratory requirements.

After each selection, press **Enter** to display the next prompt. If data results are to be e-mailed automatically after analysis, specify e-mail parameters in ["Setup Reports" on page 2 - 9](#).

Enter appropriate analysis and report parameters for the current analysis. The chosen or specified parameters in *Set Up* determine what prompts and information are displayed for the analysis.

Display Text	Description
Setup Type? Analysis Parameters	Press ENTER to accept <i>Analysis Parameters</i> .
Number of Purges:	Key in the number of purges to be performed. Purging cleans the sample cell and expansion chambers before an analysis begins. The greater the number of purges, the cleaner the sample will be when analyzed. The range is 0 to 999. For calibration, 10 is sufficient.
Purges Fill Pressure	Key in the fill pressure. For most applications, the default of 19.500 psig is adequate. Typically, the greater the fill pressure, the easier it is to measure the volume precisely. However, a lower pressure may be required for some samples. The range is psig is 0 to 19.850. The range in kPag is 0 to 136.86.
Number of Cycles	Key in the number of cycles to be performed. A cycle is a series of functions which equal to a single volume measurement. The range is 1 to 999. For calibration, 10 is sufficient.
Cycle Fill Pressure	Key in the fill pressure. For most applications, the default of 19.500 psig is adequate. The range is psig is 0 to 19.850. The range in kPag is 0 to 136.86.
P1, P2 end by? [selection]	Choose the manner in which to end the pressure measurement. Press CHOICE to make a selection. The available options are <i>Equilibrate</i> and <i>Fixed interval</i> .

Display Text	Description
Equilibration Rate: (Does not display for Fixed Intervals)	<p>Select <i>Equilibrate</i> at the <i>P1, P2 end by?</i> prompt. Pressure measurement will end when the entered rate is obtained. Key in the equilibration rate.</p> <p>A high rate will produce faster results, but results may not be as precise as desired. The lowest rates may cause errors when some materials (such as those with appreciable vapor pressures or organics) are analyzed.</p> <p>The default setting is 0.0050 psig/min. The range in psig/min is 0.0001 to 9.0000. The range in kPag/min is 0.0007 to 62.0500.</p>
Interval Time: (Does not display for Equilibrate)	<p>Select the <i>Fixed</i> interval at the <i>P1, P2 end by?</i> prompt. Pressure measurement ends when the specified time is reached. Key in the interval time.</p> <p>The range is 10 to 99999 s (seconds).</p>
Use Run Precision?	<p>Allows early termination of the analysis when certain criteria are met.</p> <ul style="list-style-type: none"> • Yes. The analysis terminates after five consecutive cycles are within the specified tolerance. Always request a large number (50 to 99) of runs. The number of runs is determined through the <i>Number of Cycles</i> option. With a small number of runs, the analysis stops when the selected number is reached, even if the specified tolerance has not been met. • No. <i>Run Precision</i> is not used.
Percent Full Scale:	<p>This prompt only displays if Yes is selected for <i>Run Precision</i> and more than five cycles have been requested.</p> <p>Enter the run precision volume tolerance which is expressed as a percentage of nominal cell volume (sample capacity).</p> <p>The range is 0.01% to 50.00%.</p>

SETUP REPORTS

The *Report Options* command enables the report mode (density or volume for analysis) and specification of the report destination. After analysis or calibration, the display returns to the *Reload* prompt. An asterisk (*) in the third line of the display indicates an error message exists.

```
Unit[n]>   SN1234>   10 cm3
           X - X - X
Reload                    *
P = (current pressure)
```

A report is generated automatically to the destination selected at the *Setup > Report Options* as follows:

- **Printer.** Report is automatically sent to the printer.
- **Transmission line.** Report is automatically sent through the serial line to an attached device for this purpose.
- **E-mail.** Report is e-mailed to the address specified (when connected to a network).

To view report data by points, use the *Review* function. See ["Review Data" on page 2 - 11](#).

Field or Button	Description
Setup Type? Report Options	Press CHOICE until <i>Report Options</i> is displayed.
Report Options Anls Display Mode? Density	Press CHOICE to select <i>Density</i> , <i>Volume</i> or <i>Specific Gravity</i> , the mode in which the analysis report will be displayed. When <i>Density</i> is selected, a <i>Sample Mass?</i> prompt displays during the <i>Analysis</i> function. Enter a value for the sample mass. For accurate data, the sample mass must be entered when choosing <i>Density</i> .
Report Options Request Sample ID?	A sample ID (identification) is a unique identifier of the sample. Using sample IDs can help keep track of data from multiple analyses and can be used as a date and time stamp. A <i>Sample ID</i> prompt displays during the analysis operation, allowing entry of the identification when after selecting Yes to this prompt. Press CHOICE to select <i>Yes</i> or <i>No</i> .
Report Options Request Description?	Provides entry of additional descriptive information. This prompt typically is used when a computer keyboard is attached. All system commands can be executed on the keyboard. Press CHOICE to select <i>Yes</i> or <i>No</i> .
Report Options Print Report?	Provides automatic generating of a report after an analysis or calibration. The type of printer is selected at the <i>Printer?</i> prompt. Press CHOICE to select <i>Yes</i> or <i>No</i> .

Field or Button	Description
Report Options Transmit Report?	Provides transmission of analysis or calibration data automatically after the operation. Press CHOICE to select <i>Yes</i> or <i>No</i> . See " Transmitted Data " on page <i>D - 1</i> .
Report Options E-mail Report?	Select <i>Yes</i> at this prompt to automatically send an e-mail at the conclusion of an analysis or calibration operation. An e-mail address and server must be specified in order to select <i>Yes</i> . Press CHOICE to select <i>Yes</i> or <i>No</i> .
Report Options Printer? [printer name]	Provides selection of the report printer. This is a system option and does not have to be specified for each analysis (or calibration). It also applies for all units when multiple analysis modules are attached. Press CHOICE to select the appropriate printer. See " Printer Setup " on page <i>J - 11</i> .
Report Options Transmission Format?	Select the format of data to be used when transmitting reports. Press CHOICE to select either the <i>Single Column</i> format or the <i>Spreadsheet</i> format. See " Transmitted Data " on page <i>D - 1</i> .
Report Options Request Insert?	Prompts for a MultiVolume insert during analysis or calibration operations. An insert is a device that can be placed in a sample chamber, allowing use of a smaller sample cup for analysis of smaller sample quantities. Inserts are available in MultiVolume Kits for the 1.0, 10, and 100 cm ³ pycnometers. Press CHOICE to select <i>Yes</i> or <i>No</i> . If MultiVolume inserts are not used, select <i>No</i> .
Report Options Request Cup Mass?	If <i>Yes</i> is selected, prompts user to enter the mass of the sample cup at start of analysis.
	<i>Request Cup Mass?</i> is only necessary if different size cups are used for calibration and analysis.

REVIEW DATA

The *Review* function allows review of and editing of the results of the last operation – analysis or calibration – along with its entered parameters. It is important to review and print the report before starting another operation. Data are no longer available for review on the display when another operation is started; however, data results are saved in the control module and can be reviewed using a web browser.

Review Data with a Web Browser

Data results for the last five analyses are saved in the control module for each attached unit. These results can be viewed by accessing a web browser. To use this feature, connect to a network.

1. Press **Alt + 2** to access *Setup*. Then press **CHOICE** until *Communications* is displayed.
2. Press **ENTER** to display a prompt showing that the IP Address mode is *DHCP*.



The display may show *Specify*, depending on how the IP address was assigned.

3. Press **ENTER** to view the assigned address on the display. If the address was specified, the display shows *IP Address?* and the entered address. This line is editable since it is specified and not assigned automatically. An assigned address cannot be edited.
4. Make a note of the IP address.
5. Press **Alt + CLEAR** to return to the *Reload* prompt.
6. Access the web browser and type in the IP address.
7. Press **Enter** to display the serial number(s) of the attached unit(s).

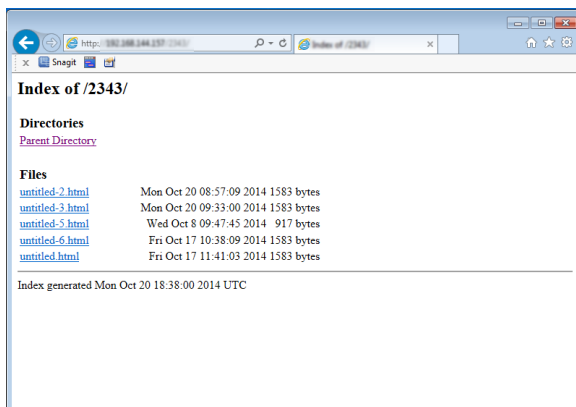

8. Click on the serial number of the unit containing the data to review. A window displaying the data files for the last five analyses, and for the zero (slope) and volume offset files is displayed.

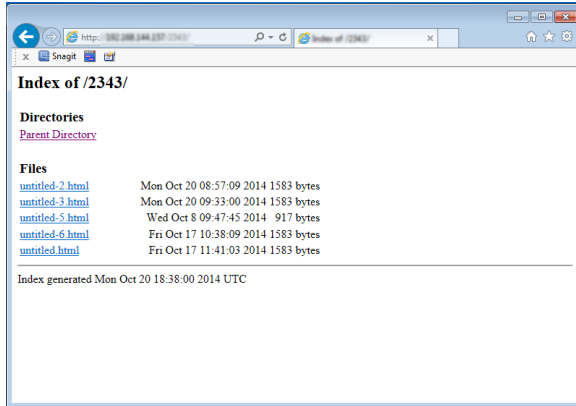

The files are in .HTML format and are assigned the name used as the *Sample ID*. If sample identifications are not used, *Untitled* is assigned and appended for each file.

- Click the file to view the data results. The progress of a current operation can be monitored by reloading the page.

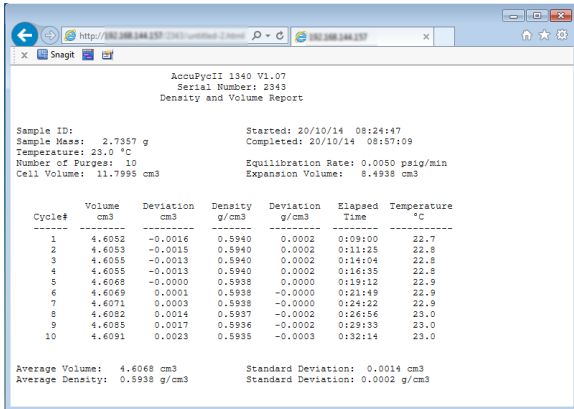

AccuPycII 1940 V1.07
Serial Number: 2343
Density and Volume Report

Sample ID: Started: 20/10/14 08:24:47
Sample Mass: 2.7357 g Completed: 20/10/14 08:57:09
Temperature: 23.0 °C
Number of Purges: 10 Equilibration Rate: 0.0050 psi/g/min
Cell Volume: 11.7998 cm³ Expansion Volume: 8.4938 cm³

Cycle#	Volume cm ³	Deviation cm ³	Density g/cm ³	Deviation g/cm ³	Elapsed Time	Temperature °C
1	4.6056	-0.0016	0.5940	0.0002	0:09:00	22.7
2	4.6053	-0.0015	0.5940	0.0002	0:11:28	22.8
3	4.6055	-0.0013	0.5940	0.0002	0:14:04	22.8
4	4.6056	-0.0013	0.5940	0.0002	0:16:35	22.8
5	4.6068	-0.0000	0.5938	0.0000	0:19:12	22.9
6	4.6069	0.0001	0.5938	-0.0000	0:21:49	22.9
7	4.6071	0.0003	0.5938	-0.0000	0:24:22	22.9
8	4.6082	0.0014	0.5937	-0.0002	0:26:56	23.0
9	4.6085	0.0017	0.5936	-0.0002	0:29:33	23.0
10	4.6091	0.0023	0.5935	-0.0003	0:32:14	23.0

Average Volume: 4.6068 cm³ Standard Deviation: 0.0014 cm³
Average Density: 0.5938 g/cm³ Standard Deviation: 0.0002 g/cm³

- Use the *File > Print* option to print a copy of the results.

VIEW DATA RESULTS

Press **Alt + 5** to view data results.

Reports are generated after analysis and calibration, and remain available for viewing or printing until another automatic operation (other than zero) is performed. When an automatic operation is performed, data from the previous operation are no longer available for viewing on the display.

A display report is always generated regardless of the specified destination and contains:

- **Analysis.** The average density (or volume) and the deviation from the mean.
- **Calibration.** Average cell (or expansion volume) and the deviation from the mean.

PRINT A FILE

Press **Alt + 6** to print a report of the last operation; analysis or calibration. If **Alt + 6** is pressed during an automatic operation, a partial report is printed.

Reports are generated after analysis and calibration, and remain available for viewing or printing until another automatic operation (other than zero pressure) is performed. Previously generated reports are deleted whenever a new automatic operation begins.

For each attached analysis module, the data for up to five analyses are stored in the control module. These data sets can be viewed using a web browser when connected to a network.

An asterisk next to a cycle number indicates that it has not been included in calculations.

- **Analysis.** Volume, density, deviation for each cycle, an average of all cycles, the date and time the analysis was started and completed, and the temperature of the cell chamber.
- **Calibration.** Cell and expansion volumes and deviations for each cycle, an average of all cycles, and the date and time the calibration started and completed.

Blank Page

3 ABOUT THE SOFTWARE

The AccuPyc II Pycnometer's unique *run precision* reports data from five consecutive runs that are within a user-specified tolerance. This feature allows early termination of analyses, thereby decreasing the number of runs needed for accurate results.

Analysis provides the measurement of sample volume, from which density can be derived automatically if the sample mass is entered. The unit comes preprogrammed with default conditions and ready to perform analyses. It can be reprogrammed to meet specific needs. Analyses can be modified by entering the number of purges and purge fill pressure, number of cycles and cycle fill pressure, equilibration rate, and run precision. Modifying these parameters allow control of the primary portions of the analysis; purge and run.

When the PC software is not running, the AccuPyc II can be operated in keypad mode. For example; if the computer is inoperative for some reason, analyses can be performed using the keypad.

If running the FoamPyc module, an option to select a Standard method is available so that analyses on other types of sample materials can be performed.

Hardware and software installation instructions are found in ["Installation Instructions" on page J - 1](#).

MENU STRUCTURE

All program functions use standard Windows menu functionality. The title bar contains a *Unit Number*. If multiple units (analyzers) are installed, ensure the appropriate unit is selected before continuing.

Main Menu Bar Options

Option	Description
File	Use to manage files.
Unit [n]	Use to perform analyses, calibrations, and other analyzer operations. A <i>Unit [n]</i> displays on the menu bar for each analyzer attached to the computer.
Reports	Use to run reports and view the results.
Options	Use to edit the default method, specify system configuration, and change presentation options.
Window	Use to manage open windows and display a list of open windows. A checkmark appears to the left of the active window.
Help	Provides access to the operator manual and information about the analyzer.

COMMON FIELDS AND BUTTONS

The fields and buttons in the following table are located in multiple windows throughout the analyzer application and have the same description or function. Fields and button descriptions not listed in this table are found in tables in their respective sections.

Common Fields and Buttons Table

Field or Button	Description
Add Log Entry	Use to enter information to appear in the sample log report that cannot be recorded automatically through the application. Click the button again to enter multiple log entries.
Autoscale checkbox	When enabled on report parameters windows, allows the x- and y-axes to be scaled automatically. <i>Autoscale</i> means that the x- and y- ranges will be set so that all the data is shown. If <i>Autoscale</i> is not selected, the entered range is used.
Axis Range	On report parameters windows, the <i>From / To</i> fields are enabled when <i>Autoscale</i> options are not selected. Enter the starting and ending values for the x- and / or y-axes.
Bar Code	Enter bar code reader information if a bar code reader is connected to the computer's USB port. If a bar code reader is not used, this alphanumeric field can be used to enter additional information about the sample, such as a sample lot number, sample ID, etc.
Browse	Searches for a file. Select a file from the <i>Name</i> column or from the library, then click Open . Alternatively, double click the file name to open (or import) the file.
Cancel	Discards any changes or cancels the current process.
Close	Closes the active window.
Close All	Closes all active windows. If changes were made and not yet saved, a prompt displays for each changed file providing the option to save the file.
Comments	Enter comments about the sample or analysis. Comments display in the report header.
Delete	When working with report parameters, Delete removes the selected report. Deleted reports will have to be regenerated if deleted in error.

Common Fields and Buttons Table (continued)

Field or Button	Description
Destination group box	<ul style="list-style-type: none"> • Preview. Previews the predefined report on the screen. • Print. Sends the report to the default printer. • Copies. Select the number of copies to print. This field is only enabled when <i>Print</i> is selected. • File. Select the destination directory. Enter a new file name in the <i>File name</i> field, or accept the default. Select to save the file as a report system (.REP), a spreadsheet (.XLS), a portable document format (.PDF), or an ASCII text (.TXT) file format.
Edit	When working with report parameters, highlight the item in the <i>Selected Reports</i> list box and click Edit to modify the report details.
Exit	If a file is open with unsaved changes, a prompt displays providing the option to save the changes and exit or to exit the application without saving the changes.
Export	Exports isotherm data in a sample information file as a .TXT or .XLS file. When saved to a file, the data can be imported into other applications.
File name text box	Select a file from either the <i>Name</i> column or from the library. The file name displays in the <i>File name</i> text box. Click Open or double click the file name to open the file. To select more than one file, hold down the Ctrl key on the keyboard while selecting the files, or hold down the Shift key to select a range of files.
From / To text boxes	When working with report parameters windows, enter the <i>From</i> and <i>To</i> range for x- and / or y-axes.
List	Provides the option to create a list of sample or report options file information, for example, file name, date / time the file was created or last edited, file identification and file status.
Name column	A list of files in the selected directory or library.
Next	Click to move to the next window or next step.
OK	Saves and closes the active window.
Open	Opens the selected file. Alternatively, double click the file name in the <i>Name</i> column to open the file.
Prev	Click to move to the previous window.
Print	Sends the report to the selected destination (screen, printer or file).
Remove	Click to remove an item from the list.
Replace	Click to select another file where the values will replace the current file's values.

Common Fields and Buttons Table (continued)

Field or Button	Description
Replace All	Click to select another .SMP file where the values will replace all values for the active Sample Information file. The original file will remain unchanged.
Report	Click to display a window to specify report output options. <ul style="list-style-type: none"> • Start Date. Displays a calendar to select the start date for the report. • Preview. Previews the predefined report on the screen. • Print. Sends the report to the default printer. • Copies. Select the number of copies to print. This field is only enabled when <i>Print</i> is selected. • File. Select the destination directory. Enter a new file name in the <i>File name</i> field, or accept the default. Select to save the file as a report system (.REP), a spreadsheet (.XLS), a portable document format (.PDF), or an ASCII text (.TXT) file format.
Save	Saves changes to the active window.
Save As	Saves a file in the active window under a different file name.
Start	Starts the report, test, analysis, or operation.

OPTION PRESENTATION

Options > Option Presentation

Use to change the way sample files and parameter files display: *Advanced*, *Basic*, or *Restricted*. Each display option shows sample information and options differently.

Presentation Display Table

Presentation Display	Description
Advanced	Displays all parts of sample information and parameter files. Navigate to parameter windows by selecting the tabs across the top of the window.
Basic	Displays sample information in a single window. This display option is used after the parameter files have been created. The previously entered or default parameter files are then accessible using drop-down lists.
Restricted	Displays the sample information file in a single window similar to the <i>Basic</i> display option with certain functions disabled. A password is set when the <i>Restricted</i> option is selected. That same password must be entered to change to the <i>Basic</i> or <i>Advanced</i> display option. This display type is typically used in laboratories where analysis conditions must remain constant — such as the pharmaceutical industry. The <i>Advanced</i> option is not available at the bottom of the window when using the <i>Restricted</i> display option.

FILE STATUS, DESCRIPTION, EXTENSION, AND LOCATION

In the *File Selector* window, the *Mic Description* column and the *Mic Status* column display file description and file status. The *File Selector* incorporates standard Windows features for resizing windows, reordering and repositioning columns, and right clicking an entry to display a menu of standard Windows functions.

File Status and Description Table

File Status	Description
Analyzing	Sample information files that are currently being used for analysis.
Complete	Sample information files used in an analysis that has been completed.
No Analysis	Sample information files which have not been used to perform an analysis.

File Type, Extension, and Location Table

File Type	File Name Extension	Default Location
Analysis conditions	.ANC	Param Directory
Report options	.RPO	Param Directory
Sample cup	.CUP	Param Directory
Sample information	.SMP	Param Directory
The following file types are available when printing or exporting reports:		
Spreadsheet	.XLS	
Unicode	.TXT	

APPLICATION SHORTCUTS

MENU SHORTCUTS

Shortcut menus are available for:

- the analyzer schematic when manual control is enabled
- onscreen graphs and tabular reports.

KEYBOARD SHORTCUTS

Shortcut keys can be used to activate some menu commands. Shortcut keys or key combinations (when applicable) are listed to the right of the menu item.

Certain menus or functions can also be accessed using the **Alt** key plus the underlined letter in the menu command. For example, to access the File menu, press **Alt + F**, then press the underlined letter on the submenu. For example, **Alt + F** opens the File menu, then press **O** to access the *File Selector* for opening files.



If the underscore does not display beneath the letter on the menu or window, press the **Alt** key on the keyboard.

Keyboard Shortcut Table

Key	Description
F1	Access the operator manual.
F2	Opens the File Selector window listing sample information files.
F3	Opens the File Selector window listing analysis conditions files.
F5	Opens the File Selector window listing report options files.
F6	Tile windows.
F7	Cascade windows.
F8	Start a report.
F9	Close all open reports.
Alt + F4	Exit the program.
Shift + F2	List sample information files.
Shift + F3	List analysis conditions files.
Shift + F5	List report options files.

SAMPLE DEFAULTS

Options > Sample Defaults

A *Sample Default* determines the default sample identification format and sequence number. A *Sample Default* is a template of specifications that go into a newly created sample file. It allows for the definition of complete sets of parameters for each type of sample commonly analyzed, so that only a single selection is required for each new sample file created.

EDIT A SAMPLE DEFAULT FILE

Options > Sample Defaults

See ["Create Sample Files using Advanced Presentation Option" on page 4 - 2.](#)

ANALYZER STATUS

SHOW INSTRUMENT LOG

Unit [n] > Show Instrument Log

Use to display a log of recent analyses, calibrations, errors, or messages.

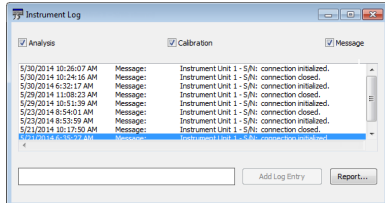

Instrument Log Fields and Buttons Table

Field	Description
Analysis / Calibration / Message	Select the logs to display.
	For fields and buttons not listed in this table, see the <i>Common Fields and Buttons</i> section of this operator manual.

SHOW INSTRUMENT SCHEMATIC

Unit [n] > Show Instrument Schematic

Use to display an analyzer schematic. To operate the valves and elevator from this window, manual control must be enabled (**Unit [n] > Enable Manual Control**).

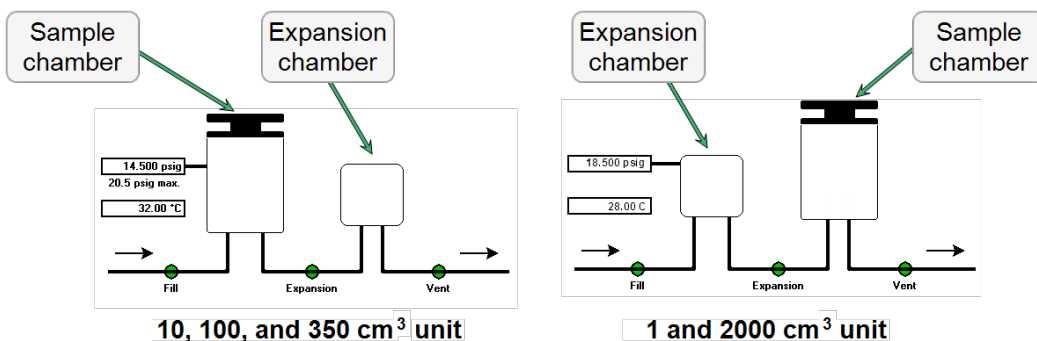

Analyzer Schematic Icon Table

Icon or Symbol	Description
	Open Valve. Green indicates an open valve.
	Closed Valve. Yellow indicates a closed valve with manual control enabled.
	Closed Valve. White indicates a closed valve with manual control not enabled
	Sample Chamber.
	Expansion Chamber.
 18.500 psig 20.5 psig max. 28.00 °C	Pressure and temperature readings. Displays for either the expansion chamber or the sample chamber, depending on the unit configuration.
	Gas flow direction.

Instrument Schematic Shortcut Menus

Each manually controlled schematic component has a shortcut menu displaying the operations available for that particular component. To access the shortcut menu, hover the mouse pointer over the component and right click.

Schematic Shortcuts Table

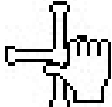
Schematic Shortcut Icon	Available Options:
	<ul style="list-style-type: none"> • Close. Closes the selected valve. • Open. Opens the selected valve.

SHOW STATUS

Unit [n] > Show Status

Use to show the current status for each port. If multiple units are attached to the computer, go to **Unit [n] > Show Status** for the indicated unit.

Sample:	Idle	Pressure:	18.500 psig
Operation:	Idle	Temperature:	28.00 °C
Elapsed Time:		Cycle:	
Equilibration:			
Density:			

Sow Status Fields and Buttons Table

Field or Button	Description
Cycles	The current cycle and the number of cycles requested. For example, 2 (current) of 10 (requested).
Density	Last computed density and standard deviation, if applicable.
Elapsed Time	The elapsed time of the current step.
Equilibration	The measured equilibration rate and the limit.
Operation	The operation, task, and the step in progress.
Pressure	The pressure in the sample chamber.
Sample	The name of the sample file being analyzed.
Temperature	The temperature of the sample chamber.
	<p>For fields and buttons not listed in this table, see the <i>Common Fields and Buttons</i> section of this operator manual.</p>

PRINT, LIST, OR EXPORT FILES

File > Print > [File Type]

File > List > [File Type]

File > Export > [File Type]

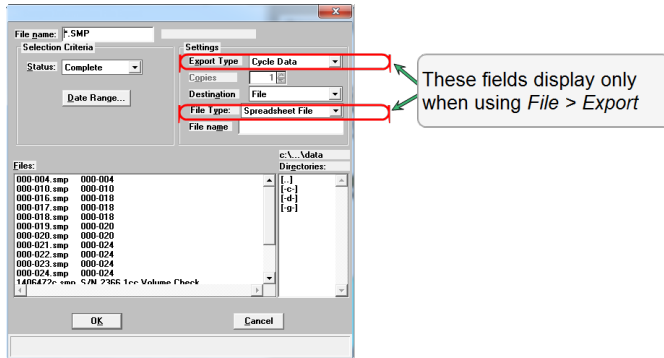

File Print, List or Export Fields and Buttons Table

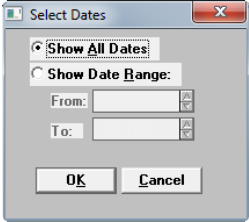
Field or Button	Description
Date Range	Click to filter by a date range. 
Directories: c:\...\data	Displays directories where files are found.
Export Type (Export feature only)	<ul style="list-style-type: none"> • Cycle Data. Exports as five columns containing the elapsed time, P1 (fill pressure), P2 (expansion pressure), Volume, and Temperature. • P[n] Equil Data. Exports as one column of equilibration data.
File name	Enter the name of a new sample file.
File Type (Export feature only)	Select either .XLS or .TXT.
Files	Displays the files that fit the search criteria. To select more than one file, hold down the Ctrl key on the keyboard while selecting the files, or hold down the Shift key to select a range of files.

File Print, List or Export Fields and Buttons Table (continued)

Field or Button	Description
Status	<p>To filter by file status, select a status from the drop-down list.</p> <ul style="list-style-type: none"> • All. Displays all files • Analyzing. Sample information files that are currently being used for analysis. • Complete. Sample information files used in an analysis that has been completed. • No Analysis. Sample information files which have not been used to perform an analysis.
 <p>For fields and buttons not listed in this table, see the <i>Common Fields and Buttons</i> section of this operator manual.</p>	

OPEN A FILE



File > Open > [File Type]

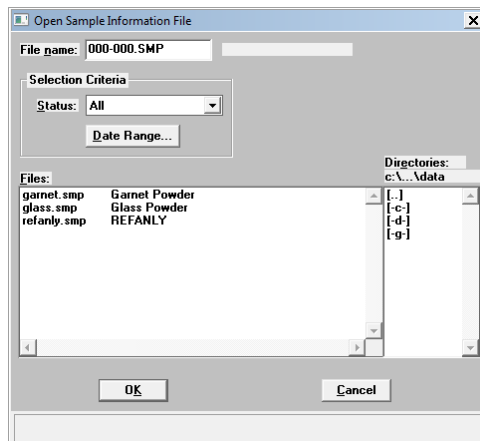

When working with an existing file, it is recommended that a copy of the file be used rather than the original.

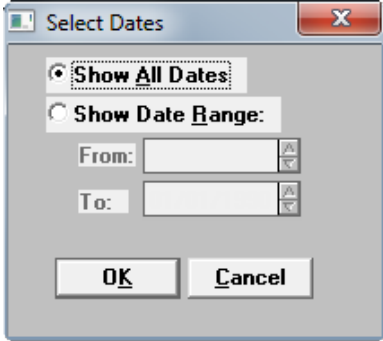

Fields and buttons will vary depending on the file type selected.

Field or Button	Description
Date Range	Click to filter by a date range. 
Directories: c:\...\data	Displays directories where files are found.
File name	Enter the name of a new sample file.
Files	Displays the files that fit the search criteria.
Status	To filter by file status, select a status from the drop-down list. <ul style="list-style-type: none"> • All. Displays all files • Analyzing. Sample information files that are currently being used for analysis. • Complete. Sample information files used in an analysis that has been completed. • No Analysis. Sample information files which have not been used to perform an analysis.
	For fields and buttons not listed in this table, see the <i>Common Fields and Buttons</i> section of this operator manual.

UNINSTALL THE SOFTWARE

When the software is uninstalled, only the files required to run the application are removed. Parameter files, sample files, reports, calibration files, and data files are not removed.

1. Insert the *Setup* CD into the CD drive.
2. Select the *Uninstall* option.
3. Follow the prompts.

INSTALLING ANALYZER SOFTWARE UPGRADE

To install software upgrade on the AccuPyc II module:

1. Turn the **On/Off switch** on the rear panel in the *Off* (O) position.

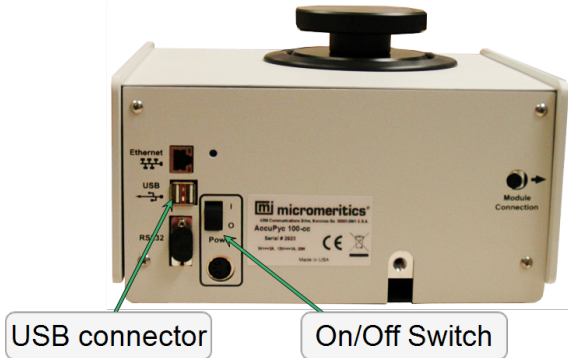

2. Insert the USB stick containing the software update into one of the USB connectors on the rear panel.
3. Place the **On/Off switch** in the *On* (|) position.
4. After approximately 1-2 minutes of initialization, the software starts to load. The following prompt is displayed:

Updating Application
from USB Media

5. Once the software is successfully installed, the display will read:

Update Successful
Remove USB Media

6. Remove the USB stick and store in a secure location.

4 ABOUT SAMPLE FILES

Sample files include the information required by the analyzer to perform analyses and collect data. It identifies the sample, guides the analysis, and specifies report options and may be created in either *Advanced*, *Basic*, or *Restricted* presentation display option.

A sample information file can consist of parameter sets; however, parameter sets can also stand alone. A sample information file may be created either prior to or at the time of analysis.

Parameter sets allow repeated use of the file. For example, if the same analysis conditions exist for multiple analyses, an *Analysis Conditions* file containing the recurring conditions can be created. When the sample file is created, the *Analysis Conditions* file can be selected for the analysis conditions. Once it becomes part of the new sample file, the new file can be edited as needed without affecting the original *Analysis Conditions* file.

The analysis software contains a sample default method. A default method is a template for sample files that contains the parameters to be used for an analysis. When a new sample information file is created, all the parameters are filled with the values in the sample default. See ["Create Sample Files" on the next page](#).



Specify or change the default presentation option by selecting **Options > Option Presentation**, or select *Basic* or *Advanced* from the drop-down list at the bottom of the window.

CREATE SAMPLE FILES

CREATE SAMPLE FILES USING ADVANCED PRESENTATION OPTION

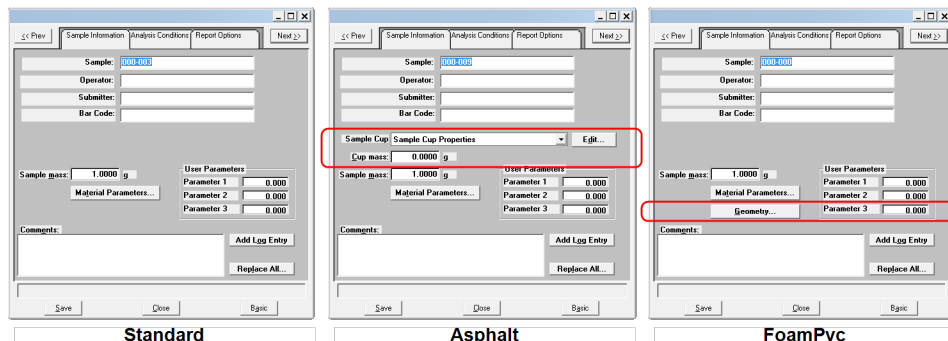

Each analysis must be linked with a sample information file before the analysis can proceed. A sample information file can consist of parameter files; however, parameter files can also stand alone. See ["About Parameter Files" on page 5 - 1](#).

Specify or change the default display option by selecting **Options > Option Presentation** or click **Basic** or **Advanced** at the bottom of the window.

The values specified in the parameter portions of the default sample file are saved as the defaults for new sample files. To navigate from one set of parameters to another, select the parameter tab across the top of the window.

1. Go to **Options > Option Presentation > Advanced** and ensure *Advanced* has a checkmark.
2. Go to **File > Open > Sample Information**.
3. Enter a new file name in the *File name* text box. Click **OK**.
4. Enter a sample description in the *Sample* text box.
5. Enter *Operator*, *Submitter*, and *Bar Code* identification information in the respective text boxes. This information will display on the *Sample Information* tab of new sample files. This option may not display (or may have a different field label) if modified in the sample default method. See ["Sample Defaults" on page 3 - 8](#).
6. If running the TEC module, select the Sample Cup from the drop-down list and enter the cup mass in the Cup Mass field. See ["Sample Cup" on page 4 - 5](#). If not running the TEC module, skip this step.
7. In the *Sample Mass* field, enter the sample mass.
8. Click **Material Parameters** to specify material parameters using the Standard method. See ["Material Parameters" on page 4 - 6](#).
9. The optional user-defined fields in the *User Parameters* group box may be used to enter and track information from another analyzer or source, along with other statistical process control (SPC)

data.

10. Enter any pertinent information about the sample information file in the *Comments* text box. Entered comments are displayed in the report header.
11. Click **Add Log Entry** to enter notes for the analyzer log report. Create entries that cannot be recorded automatically through the software.
12. To auto-populate fields from another .SMP file, click **Replace All**, then select a .SMP file that contains the preferred parameters. Select the file, then click **OK**.
13. After completing the *Sample Information* tab, click the other parameter tabs to edit more sample information file parameters See ["About Parameter Files" on page 5 - 1](#).
14. Click **Save**, then click **Close**. To save as a different file name, go to **File > Save As** and enter a new file name. The file can also be saved as a different file type such as Analysis Conditions, Report Options, etc.

Sample File Fields and Buttons Table

Field or Button	Description
Cup mass	Enter the cup mass.
Geometry *	Enter material properties when using the FoamPyc Method. <ul style="list-style-type: none"> • User Computed. Select to enter the geometric volume and when using Method A, the <i>Active Area</i>. <i>Active Area</i> is the total geometric surface area of the sample - excluding any sides that contain a skin. • Compute. Select the shape of the sample and enter the dimensions. • Number of Pieces. The number of pieces making up the sample.
Operator	Enter operator identification information. This field label may have been renamed or may not display if modified in Options > Sample Defaults .
Sample	Enter a sample description.
Sample cup	Select a sample cup file from the drop down list or click Edit to create and save a new file for sample cup properties. See "Sample Cup " on page 4 - 5 .

Sample File Fields and Buttons Table (continued)

Field or Button	Description
Sample mass	Enter the sample mass.
Submitter	Enter submitter identification information. This text box may have been renamed or may not display if modified in Options > Sample Defaults .
User Parameters group box	<p>These fields are primarily used for the SPC (Statistical Process Control) reporting to specify sample characteristics or its manufacturing process but may be used for other data by entering specific analysis conditions or sample criteria.</p> <p>The entered parameters display on the <i>Summary Report</i>. This option may not display (or may have a different field label) if modified in the through Options > Sample Defaults.</p>
* Option displays only in the FoamPyc application.	
 <p>For fields and buttons not listed in this table, see the <i>Common Fields and Buttons</i> section of this operator manual.</p>	

CREATE SAMPLE FILES USING BASIC OR RESTRICTED PRESENTATION OPTION

File > Open > Sample Information

The *Basic* and *Restricted* formats use predefined parameter files to create a sample information file.



When using the *Basic* presentation option, switch to *Advanced* to edit parameter file values. When using the *Restricted* presentation option, parameter files cannot be edited.

1. Go to **Options > Option Presentation > Basic** (or **Restricted**).
2. Go to **File > Open > Sample Information**.
3. Enter a new file name in the *File name* text box. Click **OK**.
4. In the *Sample* field, enter a sample description.
5. In the *Sample mass* field, enter the sample mass.
6. Click the down arrows to select default parameter files *Analysis Conditions* and *Report Options*.
7. Click **Material Parameters** to specify material parameters using the Standard method. See ["Material Parameters" on page 4 - 6](#).
8. In the *Selected Reports* list box, double click reports applicable to this sample file.
9. Click **Save**, then click **Close**.

SAMPLE CUP

File > Open > Sample Cup

(or click the *Sample Information* tab when in Advanced presentation display)

Use to set the sample cup mass and density. This option is available if enabled in **Options > Option Presentation > Show Cup Properties**.

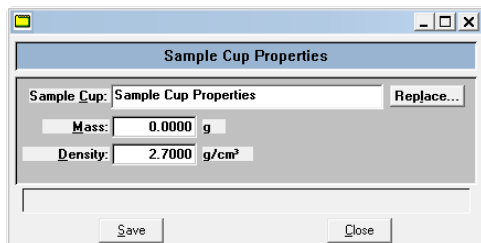

Sample Cup Properties Fields and Buttons Table

Field or Button	Description
Density	Enter the density of the sample cup.
Mass	Enter the sample cup mass.
Sample Cup	Enter a description of the sample cup.
 For fields and buttons not listed in this table, see the <i>Common Fields and Buttons</i> section of this operator manual.	

To have multiple cup selections available in the *Sample Cup* drop down list:

1. Go to **File > Open > Sample Cup**.
2. Enter a file name, click **OK**.
3. Complete the fields for the new sample cup.
4. Click **Save** and the selection will be available in the *Sample Cup* drop down list.

MATERIAL PARAMETERS

File > Open > [.SMP File]

Click **Material Parameters** on the *Sample Description* window. Material parameters are used to report porosity or total solids concentration when using the *Standard* analysis method.

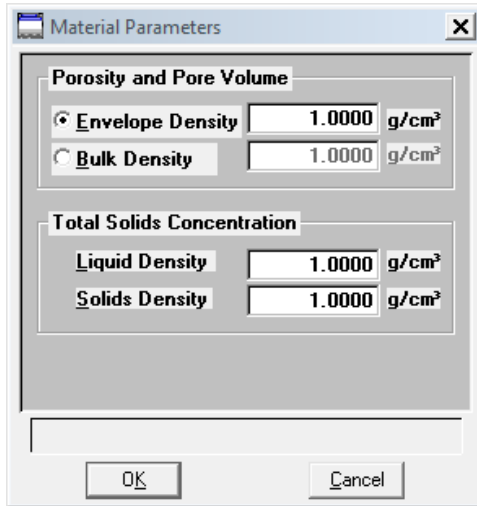

Material Parameters Fields and Buttons Table

Field or Button	Description
Bulk Density / Envelope Density	Calculated from a volume that includes pores.
Liquid Density	Density of the liquid.
Solids Density	Density of the solid sample.
	For fields and buttons not listed in this table, see the <i>Common Fields and Buttons</i> section of this operator manual.

5 ABOUT PARAMETER FILES

Parameter sets allow repeated use of the file. For example, if the same analysis conditions exist for multiple analyses, an *Analysis Conditions* file containing the recurring conditions can be created. When the sample file is created, the *Analysis Conditions* file can be selected for the analysis conditions. Once it becomes part of the new sample file, the new file can be edited as needed without affecting the original *Analysis Conditions* file.

The following file types can exist as part of the sample information file as well as individual parameter files:

File Type	File Extension
Analysis Conditions	.ANC file extension
Material Parameters	.MTP file extension
Report Options	.RPO file extension
Sample Cup	.CUP file extension

PARAMETER FILES DIRECTORY

Options > Parameter Files Directory

Use to select the location for the predefined parameter files displayed in the drop-down lists when using the Basic or Restricted presentation option. This configuration option is not available if using the Restricted presentation option.



The system default directory is the recommended location for saving report options files. The default directory is ..\param, if accessed from the top-level installation directory.

ANALYSIS CONDITIONS

File > Open > Analysis Conditions

(or click the *Analysis Conditions* tab when in Advanced presentation display)

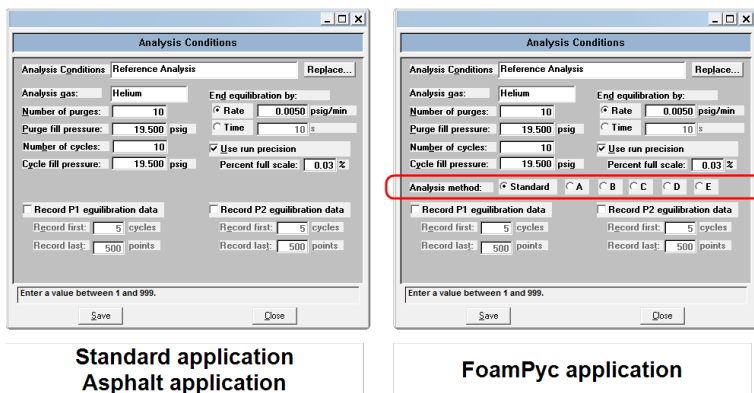

Analysis conditions specify the data used to guide an analysis.

1. Go to **File > Open > Analysis Conditions** and open the analysis conditions (.ANC) file.
2. Click **Replace** to overwrite analysis conditions with parameters from another *Analysis Conditions* file. Select the file containing replacement parameters and click **OK**.
3. Use the *Analysis Conditions Fields and Buttons Table* to complete the remaining options.
4. Click **Save**, then click **Close**.

Analysis Conditions Fields and Buttons Table

Field or Button	Description
Analysis Conditions	Displays the description of the file. If this is a new file, the description specified in sample defaults is displayed.
Analysis gas	The gas to be used for analysis gas (helium is recommended).
Analysis method	See "FoamPyc Application" on page 5 - 4 .
Cycle fill pressure	Enter the fill pressure for the cycles. Typically, the default of 19.500 psig is appropriate for most samples.
End equilibration by:	<ul style="list-style-type: none"> • Rate. Equilibration ends when the rate of pressure change drops below the entered amount. • Time. Equilibration ends when the specified time interval is attained.
Number of cycles	The number of cycles to be performed. A cycle is a series of functions which equals to a single volume measurement.

Analysis Conditions Fields and Buttons Table (continued)

Field or Button	Description
Number of purges	The number of purges to be performed. A higher number of purges will mean a cleaner sample.
Percent full scale	Enabled when <i>Use run precision</i> is selected. Enter the run precision volume tolerance which is expressed as a percent of nominal cell volume (sample capacity).
Purge fill pressure	The purge fill pressure (in psig or kPa). For FoamPyc analyses, the typical pressure is 3.5 psig. For analyses on standard samples, the measured volume is more precise if a greater fill pressure is used. The default of 19.500 is appropriate for most standard analyses. Some materials, such as organic polymers, may require a lower pressure in order to limit permeability into the sample matrix.
Record P1 equilibration data Record P2 equilibration data	<ul style="list-style-type: none"> • Record first. Enter the number of cycles to be recorded at the beginning of the analysis. • Record last. Enter the number of points to be recorded at the end of equilibration.
Use run precision	Select to use run precision. This feature provides early termination of the analysis when certain criteria are met. The analysis terminates after five consecutive cycles are within the specified tolerance. Typically, a large number (50 to 99) of cycles is requested. If a small number of runs is selected, the analysis stops when the entered number is reached even though the specified tolerance has not been met. If fewer than five cycles are requested, this feature is disabled. See "Run Precision" on page B - 6.
	For fields and buttons not listed in this table, see the <i>Common Fields and Buttons</i> section of this operator manual.

FOAMPYC APPLICATION

1. Select **File > Open > Analysis Conditions** to display the *Open Analysis Conditions File* dialog.
2. Enter a name in the *File name* field, then click **OK**.
3. Click **Yes** to create the file; the *Analysis Conditions* dialog is displayed.
4. Enter a description in the *Analysis Conditions* field.
5. Complete the following fields:
 - *Number of purges*
 - *Purge fill pressure*
 - *Number of cycles*
 - *Cycle fill pressure*
6. Choose whether to have equilibration end by rate or time, then enter a value in the adjacent field.
7. If using the *run precision* feature, select the option and enter an appropriate value in the *Percent full scale* field.
8. Choose the *Analysis method* for this file, then complete the fields that display for that method.

Analysis Methods (FoamPyc Only)

Choice	Required Action
Standard	Select <i>Record equilibration data</i> then enter the criteria (if recording equilibration data).
A, B, or C	Enter the Resin density.
D	Enter the initial and final pressure, and the pressure increment.
	Enter Resin density.
E	Enter the Low pressure and the Fracture pressure.
	Enter Resin density.

9. Click **Save**, then **Close**.

REPORT OPTIONS

File > Open > Report Options

(or click the *Report Options* tab when in Advanced presentation display)



If using the FoamPyc application, reports for all FoamPyc *Methods* are fixed and cannot be created or selected from within the application.

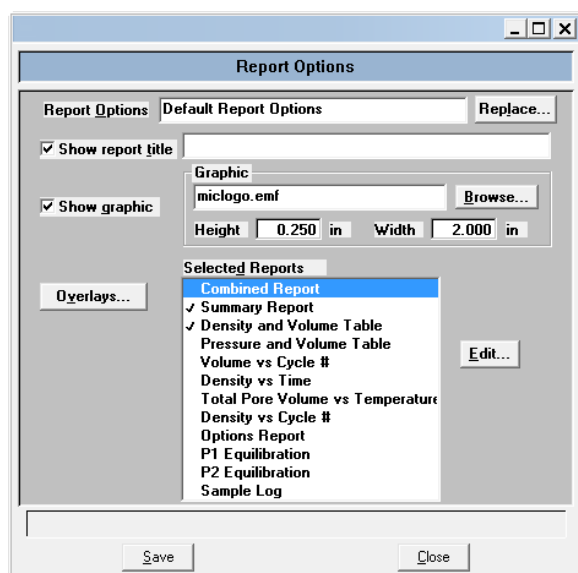

Report options specify the types of reports to be generated from an analysis and allow for customization of reports such as axis scale, axis range, and column headings.

Report Options files can be customized to accommodate standard analysis requirements. Reports can be generated automatically after each analysis or at any time during or after an analysis. A report generated during an analysis only includes data collected up to the time of the report.

Report Options files may be defined to include overlay options. This system allows the overlay of up to 8 plots of different samples onto a plot of the same type or overlay one plot type onto a different plot type from the same analysis. See ["Graph Overlays" on page 7 - 20](#).

1. Go to **File > Open > Report Options** and open the report options (.RPO) file.
2. Click **Replace** to overwrite report options with parameters from another *Report Options* file. Select the file containing replacement parameters and click **OK**.
3. Use the *Report Options Fields and Buttons Table* to complete the remaining options.
4. Click **Save**, then click **Close**.

5. The *Selected Reports* list box displays the reports that may be generated.
 - To include a report in this file, double click the report name and ensure a check mark appears to the left.
 - To specify report options, highlight the report in the *Selected Reports* list box, then click **Edit**. Make changes as necessary. Click **OK**. See ["Selected Reports" on page 8 - 1](#) for details.
8. Click **Save**, then click **Close**.

Report Options Fields and Buttons Table

Field or Button	Description
Overlays	Click to open the <i>Graph Overlay Samples</i> window. Click Browse to select sample files to overlay into a plot. See "Graph Overlays" on page 7 - 20 .
Report Options	Displays the description of the file. If this is a new file, the description specified in sample defaults is displayed.
Selected Reports list box	Select the report names to include in the report.
Show graphic	Use to show a graphic on the report header. Click Browse to locate the graphic. <ul style="list-style-type: none"> • Height / Width. Enter the height and width of the selected graphic. These values determine the graphic appearance on the generated report.
Show report title	Select and enter a report title to appear on the report header.
	For fields and buttons not listed in this table, see the <i>Common Fields and Buttons</i> section of this operator manual.

COLLECTED DATA

The *Collected Data* tab displays after an analysis has been completed.

	Elapsed Time (mm:ss)	P1 Pressure (psig)	P2 Pressure (psig)	Volume (cm ³)	Temperature (°C)	Exclude
1	7:36	19.807	9.879	2.2418	23.72	
2	9:55	19.834	9.890	2.2446	23.74	
3	12:28	19.784	9.868	2.2410	23.75	
4	15:06	19.812	9.882	2.2408	23.77	
5	17:49	19.817	9.883	2.2423	23.78	
6	20:11	19.849	9.898	2.2437	23.80	
7	22:26	19.907	9.928	2.2434	23.83	
8	24:50	19.900	9.923	2.2457	23.83	
9	27:20	19.867	9.909	2.2417	23.85	
10	29:46	19.850	9.900	2.2428	23.87	

Chamber Insert: None 3.5 cm³ 1.0 cm³

Cell Volume: cm³

Expansion Volume: cm³

Enter a value between 0.5000 and 9999.9999.

Collected Data Fields and Buttons Table

Field or Button	Description
Cell Volume	Nominal cell volume for the unit or for the selected insert.
Chamber Insert	Select the chamber insert size, if applicable. Options will vary depending on the type of unit being used. Values in the <i>Volume</i> column are recalculated automatically if the <i>Chamber Insert</i> selection is changed.
Expansion Volume	Expansion volume for the current unit or for the selected insert.

Collected Data Fields and Buttons Table (continued)

Field or Button	Description
Pressure Table Columns	Displays information collected during analysis: <ul style="list-style-type: none"> • Elapsed Time • P1 Pressure (fill) • P2 Pressure (expansion) • Volume • Temperature • Exclude. Click the cell for each cycle to exclude in the average calculations. An x in the cell indicates the cycle will be excluded. Excluded parameters are marked with an asterisk (*) in the generated report.
	For fields and buttons not listed in this table, see the <i>Common Fields and Buttons</i> section of this operator manual.

6 PERFORM AN ANALYSIS

An analysis can be performed from either the computer application or directly from the keypad on the analyzer. If using the keypad only, see ["About the Keypad" on page 2 - 2](#).

See ["Handling System Components" on page J - 1](#).

PREPARING AND LOADING SAMPLE

FOAMPYC METHODS

FoamPyc Methods are intended to conform to the procedures detailed in ASTM Test Methods D-6226 and D-3576. Prepare samples according to the methods outlined in these procedures. Once the sample is prepared and placed it into the sample chamber, see ["Start an Analysis" on page 6 - 3](#).

STANDARD METHOD

Samples must be properly prepared to obtain accurate results. Samples must be free of moisture in order to obtain true sample mass and to avoid the distorting effect of water vapor on the volume measurement. The following procedures are recommended; however, modifications may be necessary for some materials.

- Heat-sensitive materials may have to be dried by long-time exposure to silica gel, freeze drying, etc.
- Materials having a low melting point may be dried using the purge process. In this case, do not weigh the sample and cup until after the purge and analysis have been completed.

Avoid exposure of the dried sample to atmospheric moisture during each step of the preparation process. This means weighing as rapidly as possible and installing in the instrument without unnecessary delay.



Keep the cap on the cell chamber except when actually inserting or removing a sample. If the chamber remains uncapped, water vapor will adsorb on the inner surface of the chamber and temperature instability will occur; either condition can affect analysis results.

1. Weigh the empty sample cup.
2. Place as large a quantity of sample as is possible in the cup (cup should be two-thirds full). Pack powders and fluffy materials (if permissible) to obtain maximum sample weight in the cup.
3. Place the sample cup with sample in a drying oven. The amount of time the sample must be heated depends on the material and the temperature it will tolerate; this may have to be established by other tests.
4. Remove the sample cup from the oven and transfer it to a desiccator provided with active desiccant. Allow it to cool until near room temperature. Minimize air exposure of the sample.
5. Use this equation to determine the sample mass. (If volume only is to be measured, skip this step.)

$$Mass_{\text{sample}} = Mass_{\text{sample+cup}} - Mass_{\text{cup}}$$

6. Remove the cell chamber cap, place the sample cup (with sample) into the cell chamber, then replace the cap.

It is best not to lay the cap down while loading the sample. Immediately replace the cap when the sample is loaded. This will prevent particles from accumulating on the greased surface (see ["Handling System Components" on page J - 1](#) for guidelines on handling system components).

7. If using a temperature-controlled AccuPyc, perform the following steps before proceeding, see ["Start an Analysis" on the facing page](#).
 - a. Turn on the bath circulator and specify the temperature for analysis. (Refer to the manufacturer manual for instructions on operating the bath circulator.)
 - b. Allow the temperature to stabilize to the set temperature. Observe the temperature reading on instrument schematic.
8. If using a TEC module, ensure the temperature reading has stabilized at the specified point.

START AN ANALYSIS

START AN ANALYSIS USING THE SOFTWARE

Unit [n] > Sample Analysis

After the sample has been properly prepared and loaded into the sample chamber, start the analysis.

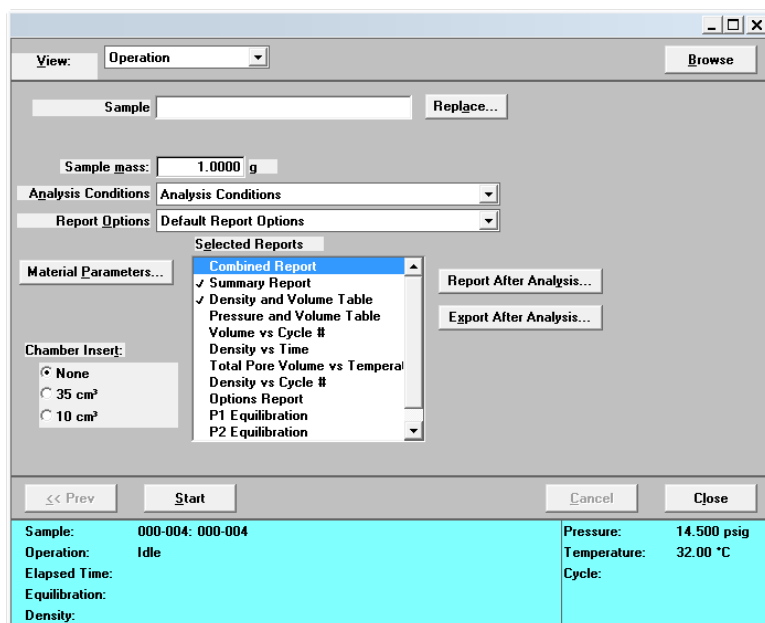

1. Go to **Unit [n] > Sample Analysis**. Select the sample file to run and click **OK**. To select a different sample file, click **Browse** and locate the correct file. If sample file parameters exist in another file, rather than re-enter them again, click **Replace** to locate and replace parameters in the current file with those of the selected file.
2. Edit or enter information for the analysis.
3. Click **Report after analysis** to generate reports automatically when the analysis is complete. On the *Report Settings* window, select the report destination. Click **OK** to return to the previous window.
4. Click **Export after Analysis** analysis to have data exported automatically after the analysis. Or, if exporting equilibration or cycle data, data can be exported after the analysis using the **File > Export**.
5. Ensure the correct *Chamber Insert* is selected.
6. Click **Start** to start the analysis. A window displays data as they are collected. A short delay is encountered before the port status at the bottom of the window changes from the *Idle* state.

7. If running a FoamPyc analysis, a message displays indicating the sample should be cut.
 - a. Remove the sample chamber cap, then remove the cap before performing the next step.
 - b. Cut the sample and return it to the cup.
 - c. Remove the cap, place the cup back into the same chamber. Replace the cap.
 - d. Click **OK** to complete the second analysis.

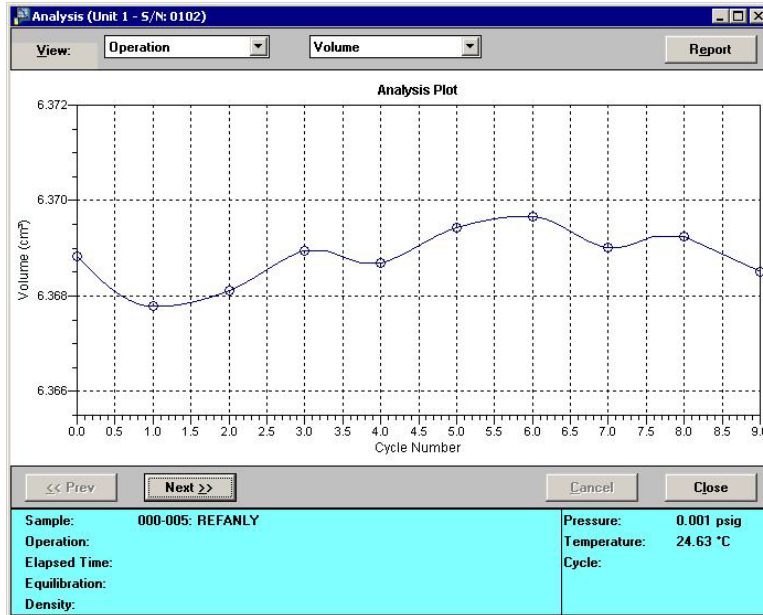

START AN ANALYSIS USING THE KEYPAD

Prerequisites:

- specify analysis and report parameters
- prepare and load sample

The prompts that display for an analysis depend on the options selected in *Setup > Analysis Parameters* and *Report Options*; therefore, the analysis may not display all of the prompts referenced in this procedure.

1. Press **Alt + 4** to display the *Sample ID* prompt. Enter an appropriate identification. Press **.** (decimal) to insert a dash.
2. Press **ENTER** to display the *Description* prompt.



Most users display this prompt only when a keyboard is attached to the pycnometer.

3. Press **ENTER** to display the *Sample Mass* prompt. At the *Anls Display Mode* prompt in the *Setup > Report Options* choose *Density*. Enter the sample mass.
4. If an analytical balance is connected to the module, press the appropriate button on the balance to transfer the sample mass while this prompt is displayed.
5. Press **ENTER** to display the *Chamber Insert* prompt if using an insert. Press **CHOICE** until the appropriate insert is displayed, then press **ENTER**.
6. Press **ENTER** to begin the analysis. Operational status messages display during analysis.
7. When the analysis has finished, the pycnometer beeps three times and the display returns to the *Reload* prompt.



Do not remove the cell chamber cap when the pycnometer is pressurized. The sample may be discharged from the chamber.

8. Ensure the pressure reads approximately 0 (zero), then remove the cell chamber cap and remove the sample from the chamber.
9. Replace the cell chamber cap or load another sample.

Display Text	Description
Analyze Sample ID:	Enter sample identification for the current analysis. Sample ID can be up to 20 numbers and dashes. Press . (decimal) to insert a dash.
Analyze Description Line 1:	Enter the description for the current sample. A prompt for Line 2 of the description is displayed.
Analyze Sample Mass:	<p>Enter a value for the sample mass. Displays only when <i>Density</i> is selected for Analysis display mode. It does not display if <i>Volume</i> is selected.</p> <p>The range is 000.0000 to 10000.0000 g.</p> <p>The range for the 2000 cm³ AccuPyc is 000.0000 to 25000.0000 g.</p> <p>This field will also accept input from a connected analytical balance. While this prompt is displayed, press the appropriate button on the analytical balance to transfer the mass (refer to the manufacturer's manual for the appropriate command).</p>

Display Text	Description
Analyze Chamber insert?	<p>Select the insert to be used.</p> <ul style="list-style-type: none"> • None, 0.1 cm³ (for 1 cm³ unit) • None, 3.5 cm³, 1.0 cm³ (for 10 cm³ unit) • None, 35 cm³, 10.0 cm³ (for 100 cm³ unit) • None, 650 cm³, 1300 cm³ (for 2000 cm³ pycnometer) <p>Press CHOICE until the appropriate insert is displayed or None if an insert is not being used.</p>
Analyze Cup Mass?	Enter the mass of the sample cup.
Analyze [ENTER] to start [ESCAPE] to cancel	<ul style="list-style-type: none"> • ENTER. Starts the analysis. The analysis begins and operational status messages are continually displayed during analysis • ESCAPE. Cancels the analysis.
 <p>For keypad and / or keyboard functions or commands not listed in this table, see the <i>Keypad and Keyboard Functions</i> section of this operator manual.</p>	

QUICKSTART ANALYSIS

Unit [n] > QuickStart Analysis

Use to analyze a series of samples of the same type and same analysis conditions. Sample files will be created using default values.

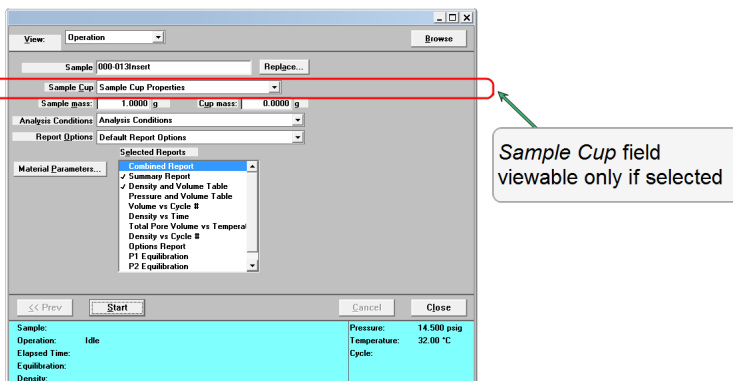

QuickStart Analysis Fields and Buttons Table

Field or Button	Description
Analysis Conditions	Select the <i>Analysis Conditions</i> file to be used for analysis. See "Analysis Conditions" on page 5 - 2.
Chamber Insert	Select the chamber insert size to be used in this analysis.
Export after analysis	Exports reports automatically to the specified destination and in the selected format when the analysis is complete.
Material Parameters	Click to verify or change the material properties to be used for analysis. See "Material Parameters" on page 4 - 6.
Report after analysis	Generates reports automatically to the specified destination when the analysis is complete.
Report Options	Select the <i>Report Options</i> file to be used for analysis. See "Report Options" on page 5 - 5.
Sample	Displays the sample description specified in the <i>Sample Defaults</i> .
Sample Cup	Select the sample cup properties file to be used for analysis. See "Sample Cup" on page 4 - 5.
Sample Mass	Enter the sample mass.
	For fields and buttons not listed in this table, see the <i>Common Fields and Buttons</i> section of this operator manual.

SEQUENCE ANALYSIS

Unit [n] > Sequence Analysis

Use to analyze the same sample using up to eight different sample files.

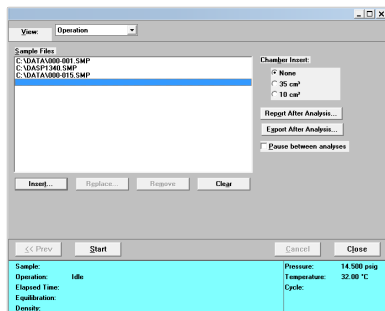

Sequence Analysis Fields and Buttons Table

Field or Button	Description
Chamber Insert	Select the chamber insert to be used for analysis.
Clear	Removes all entries from the <i>Sample Files</i> list box.
Export After Analysis	Exports reports automatically to the specified destination and in the selected format when the analysis is complete.
Insert	Click to browse and select a file to be added to the sequence analysis. The selected file displays in the <i>Sample Files</i> list box.
Pause between analyses	When using multiple sample files and this option is selected, the system will return to the sample selection window after each analysis. When the previous analysis completes, click Start to run the next analysis. As each analysis is run, the sample file is removed from the <i>Samples Files</i> list box.
Remove	Select a file in the <i>Samples Files</i> list box then click Remove to delete the file from the list.
Replace	Select a file in the <i>Samples Files</i> list box then click Replace to substitute a sample file for the selected one.
Report After Analysis	Generates reports automatically to the specified destination when the analysis is complete.
	For fields and buttons not listed in this table, see the <i>Common Fields and Buttons</i> section of this operator manual.

REVIEW ANALYSIS

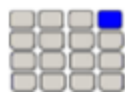

Keypad Function

The *Review* function allows review of the results of the last analysis operation. Press **Alt + 5** to review or edit analysis results. The analysis information can also be edited through the prompts. The prompts that display during the analysis review depend on the options selected in *Setup > Analysis Parameters* and *Report Options*.

1. Press **Alt + 5** to display the *Sample ID* prompt containing the sample identification.
2. Press **ENTER** to display the *Description* prompt containing an additional description. This prompt typically is not used unless a keyboard is connected to the analyzer.
3. Press **ENTER** to display the *Sample Mass* prompt containing the sample's mass.
4. Press **ENTER**. The *Start* prompt containing the start date and time of the analysis is displayed.
5. Press **ENTER**. The *End* prompt containing the ending date and time of the analysis is displayed.
6. Press **ENTER**. The first of the prompts containing data is displayed. The *[n]* displayed in the example prompts represents the cycle number.
7. Continue pressing **ENTER** to view data. Press **CHOICE** to exclude data from report calculations. An asterisk will display indicating that it will be excluded. Press **CHOICE** again to remove the asterisk.
8. Press **SAVE** to return to the *Reload* prompt.
9. Press **Alt + 6** to print report results.

Display Text	Description
Sample ID: (sample identification)	Identification entered for the analysis.
Sample Mass: (mass)	Sample mass for the analysis (if <i>Density</i> was chosen as <i>Analysis</i> display mode).
Temperature: (sample chamber temp)	Sample chamber temperature.
Start: (time) (date)	Time and date the analysis began. Time: HH:MM:SS Date: DD/MM/YY

Display Text	Description
End: (time) (date)	Time and date the analysis completed. Time: HH:MM:SS Date: DD/MM/YY
Dn[n] = (density) Dv[n] = (deviation) or V[n] = (volume) Dv[n] = (deviation)	Density or Volume (depending on the selection made for Analysis display mode). [n]: cycle number. Press CHOICE to exclude the displayed density (or volume) from the calculated average. An asterisk indicates that it has been excluded. Press CHOICE again to remove the asterisk. Each time CHOICE is pressed to exclude (or include) the value, a new deviation is calculated and displayed. Press SAVE to return to the <i>Reload</i> prompt. Press SAVE to automatically recalculate the collected data and update data reduction messages in the queue.
	For keypad and / or keyboard functions or commands not listed in this table, see the <i>Keypad and Keyboard Functions</i> section of this operator manual.

7 ABOUT REPORTS

Review this section for information on the *Reports* menu options as well as customizing and running reports.

Reports can be generated for data:

- collected on a sample that has completed analysis
- collected on a sample currently being analyzed

OPEN AND CLOSE REPORTS

Reports > Open Report... > [.REP File]

Opens saved reports.

Reports > Close Reports

Closes all open reports. This option is unavailable if reports are being generated.

START REPORTS

Reports > Start Report

1. Click *Reports*, then *Start Report*.
2. Select a file from the *Files* list. Ensure the selected file has a status of either *Complete* or *Analyzing*.. To select more than one file, hold down the **Ctrl** key on the keyboard while selecting the files, or hold down the **Shift** key to select a range of files.



If only one report file was selected in Step 1, the *Selected Reports* window displays allowing the option to select additional reports. Select additional reports as needed, then click **OK**. If multiple files were selected, the reports are displayed in a tiled format.

3. Select the report destination in the *Settings* group box, then click **OK**.
4. When the *Selected Reports* box appears, check the reports to be displayed, then click **OK**. The reports will display at the selected destination.

SPC REPORT

Reports > SPC Report Options

Use to generate reports with various Statistical Process Control (SPC) options. All selected variables must be computed for each sample file used in an SPC report; therefore, it is more efficient to select only the necessary variables.

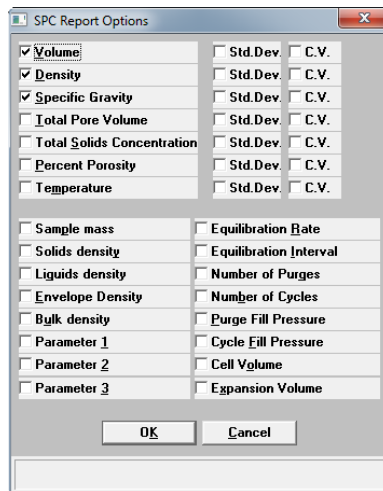



The selected items display as graph variable selections in **Reports > Regression Report** and graph selections in **Reports > Control Chart**.

REGRESSION REPORT

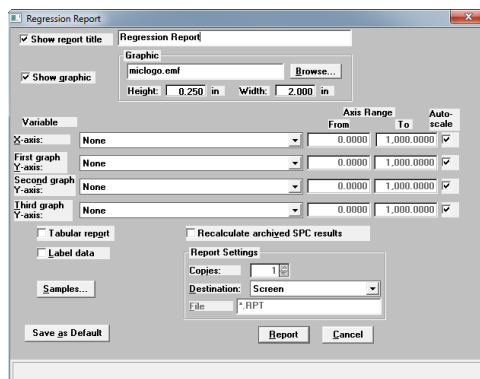
Use to generate a Statistical Process Control (SPC) *Regression* report to determine the interdependency between two variables. Up to three dependent variables (y-axis) may be plotted against a single independent variable (x-axis). The degree of correlation between the variables is also reported.



Regression Report Fields and Buttons Table

Field or Button	Description
Autoscale	When enabled, allows the x- and y-axes to be scaled automatically.
Axis Range	Enter the beginning and ending values for the x- and y-axis ranges. These fields are disabled if <i>Autoscale</i> is selected.
Label data	Use to label the points on the plot to correspond with the values in the sample files.
Recalculate archived SPC results	<p>Use to have archived SPC values recalculated ensuring any changes made to the SPC Report Options are included in the new report. This option lengthens the time required to generate the report.</p> <hr/> <div style="display: flex; align-items: center;">  <p>If this recalculation option is enabled and sample files from an earlier application version are selected, it is recommended that copies of the archived sample files be used rather than the original. Selecting this option will make some archived sample files unreadable by the original application.</p> </div> <hr/> <p>When this option is selected, the following message displays:</p> <div style="background-color: #f0f0f0; padding: 5px; margin: 5px 0;"> <p>Saving the recalculated SPC data may render some files unreadable by the original application. Saving the SPC data speeds up future SPC reports.</p> </div> <div style="background-color: #f0f0f0; padding: 5px; margin: 5px 0;"> <p>Do not show me this message again.</p> </div> <hr/> <div style="display: flex; align-items: center;">  <p>If <i>Do not show me this message again</i> is selected, the message cannot be redisplayed without Micromeritics assistance.</p> </div> <hr/> <p>The first time this option is used, the time it takes to generate the report is lengthened. The second time the report is generated, if using the same sample files used in the initial calculation, it is recommended that this option not be selected since the data was recalculated previously. If a sample file is added or removed from the report after the initial recalculation, this option should be selected again to ensure the data from the newly added or removed sample file is recalculated.</p>

Regression Report Fields and Buttons Table (continued)

Field or Button	Description
Samples	<p>To select more than one file, hold down the Ctrl key on the keyboard while selecting the files, or hold down the Shift key to select a range of files.</p> <ul style="list-style-type: none"> • Available Files. Contains files located in the directory specified in the <i>Look In</i> text box. • Selected Files. Files added from the <i>Available Files</i> list box. • Add / Remove. Select a file in the <i>Available Files</i> list box, then click Add to move the file to the <i>Selected Files</i> list box. Or select a file in the <i>Selected Files</i> list box, then click Remove to move the file back to the <i>Available Files</i> list box. Or double click the file name to move the file from one list box to the other.
Save as Default	Click to save selected report options as default report settings.
Show graphic	<p>Use to show a graphic on the report header. Click Browse to locate the graphic.</p> <ul style="list-style-type: none"> • Height / Width. Enter the height and width of the selected graphic. These values determine the graphic appearance on the generated report.
Show report title	Select and enter a report title to appear on the report header.
Tabular report	Generates a tabular report of the included samples. A tabular report contains the numeric values contributed by each sample.
X- and Y-Axis Variable	Use to designate the x- and y-axes variables. The variables in the drop-down lists are those selected in the Reports > SPC Report Options window. Use these options to plot the regression of up to three y-axis variables against the x-axis variable.
	<p>For fields and buttons not listed in this table, see the <i>Common Fields and Buttons</i> section of this operator manual.</p>

CONTROL CHART REPORT

Reports > Control Chart

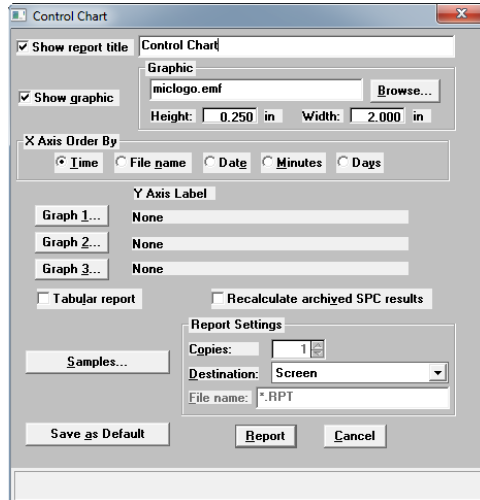

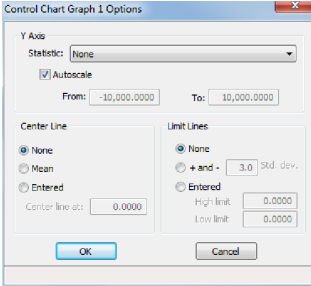

Use to generate a Statistical Process Control (*SPC*) control chart report which plots the changes in a statistic.

Control Chart Fields and Buttons Table

Field or Button	Description
Graph [n]	<p>Click to define the y-axis of each graph.</p>  <ul style="list-style-type: none"> • Statistic. Displays the SPC variables selected on the Reports > SPC Report Options window. The selected variable will be plotted against time. This selection also becomes the y-axis label. • Autoscale. Allows the y-axis to be scaled automatically. To specify a range, deselect this option and enter a range in the <i>From</i> and <i>To</i> fields. • Center Line. Displays placement options for the center line in the graph. Choose <i>Entered</i> to specify placement of the line. • Limit Lines group box. Displays limiting lines options. Lines can be placed at some multiple of the standard deviation or at specified positions (<i>Entered</i>). When <i>Entered</i> is selected, enter the <i>High limit</i> and <i>Low limit</i> fields with appropriate values.

Control Chart Fields and Buttons Table (continued)

Field or Button	Description
Recalculate archived SPC results	<p>Use to have archived SPC values recalculated ensuring any changes made to the SPC Report Options are included in the new report. This option lengthens the time required to generate the report.</p> <hr/> <div style="display: flex; align-items: center;">  <div> <p>If this recalculation option is enabled and sample files from an earlier application version are selected, it is recommended that copies of the archived sample files be used rather than the original. Selecting this option will make some archived sample files unreadable by the original application.</p> </div> </div> <hr/> <p>When this option is selected, the following message displays:</p> <div style="background-color: #f0f0f0; padding: 5px; margin: 5px 0;"> <p>Saving the recalculated SPC data may render some files unreadable by the original application. Saving the SPC data speeds up future SPC reports.</p> </div> <div style="background-color: #f0f0f0; padding: 5px; margin: 5px 0;"> <p>Do not show me this message again.</p> </div> <hr/> <div style="display: flex; align-items: center;">  <div> <p>If <i>Do not show me this message again</i> is selected, the message cannot be redisplayed without Micromeritics assistance.</p> </div> </div> <hr/> <p>The first time this option is used, the time it takes to generate the report is lengthened. The second time the report is generated, if using the same sample files used in the initial calculation, it is recommended that this option not be selected since the data was recalculated previously. If a sample file is added or removed from the report after the initial recalculation, this option should be selected again to ensure the data from the newly added or removed sample file is recalculated.</p>

Control Chart Fields and Buttons Table (continued)

Field or Button	Description
Samples	<p>To select more than one file, hold down the Ctrl key on the keyboard while selecting the files, or hold down the Shift key to select a range of files.</p> <ul style="list-style-type: none"> • Available Files. Contains files located in the directory specified in the <i>Look In</i> text box. • Selected Files. Files added from the <i>Available Files</i> list box. • Add / Remove. Select a file in the <i>Available Files</i> list box, then click Add to move the file to the <i>Selected Files</i> list box. Or select a file in the <i>Selected Files</i> list box, then click Remove to move the file back to the <i>Available Files</i> list box. Or double click the file name to move the file from one list box to the other.
Save as Default	Click to save selected report options as default report settings.
Show graphic	<p>Use to show a graphic on the report header. Click Browse to locate the graphic.</p> <ul style="list-style-type: none"> • Height / Width. Enter the height and width of the selected graphic. These values determine the graphic appearance on the generated report.
Show report title	Select and enter a report title to appear on the report header.
Tabular report	Generates a tabular report of the included samples. A tabular report contains the numeric values contributed by each sample.
X Axis Order by	<p>Select the order in which x-axis statistics are placed. Sort by:</p> <ul style="list-style-type: none"> • Time. Time the files were analyzed. • File name. Alphanumeric order. • Date. Date the files were analyzed. • Minutes. Minutes elapsed from the first file placed on the list, which is the earliest-analyzed file. • Days. Number of days elapsed from the first file placed on the list, which is the earliest-analyzed file.
	<p>For fields and buttons not listed in this table, see the <i>Common Fields and Buttons</i> section of this operator manual.</p>

REPORT FEATURES AND SHORTCUTS

Reports can be customized and manipulated using the toolbar, shortcut menus, the zoom feature, or axis cross-hairs.

- After analysis, reports can be viewed, printed, and / or copied and pasted into other documents.
- The report zoom feature provides the viewing of fine graph details and the ability to shift the axes.
- All reports contain a header displaying file statistics.

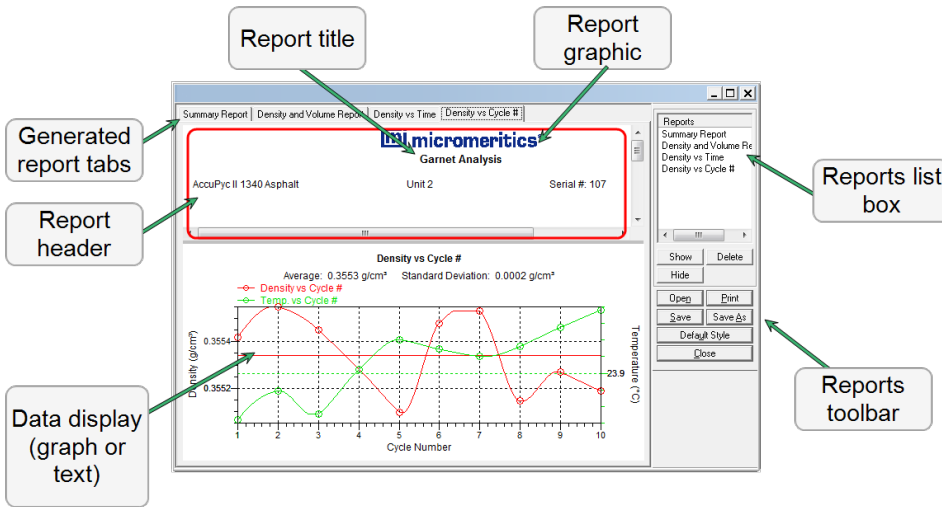

If configured, the report header can also contain a graphic and / or a title.

- Tabular and graphical reports contain sample and analyzer statistics such as analysis date / time, analysis conditions, etc.
- The headers contain notes of sample file changes occurring after analysis.
- Summary report headers contain the same information as tabular and graphical reports with the exception of notes.

REPORT HEADER SHORTCUTS

Display header shortcuts by right clicking in the report header.

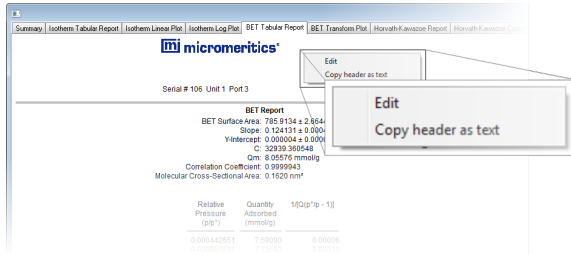

Report header Shortcut Field and Button Table

Field or Button	Description
Copy header as text	Use to copy the report header as text. Text is copied to the clipboard and then can be pasted into other documents.
Edit	Use to edit the report title and / or graphic in the report header.

REPORT TOOLBAR

The *Report* window has a toolbar on the right portion of the window and selectable tabs at the top of the report header. To view a specific report, either select the tab or the report in the *Reports* list box, then click **Show**.

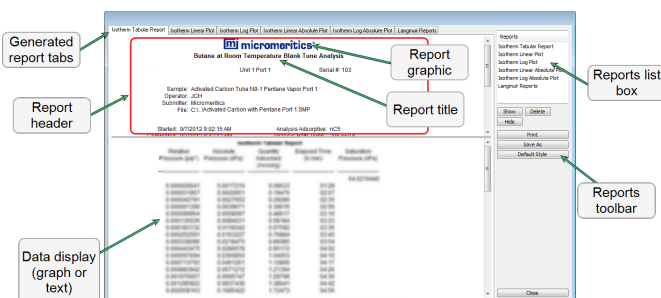

Report Toolbar Fields and Buttons Table

Field or Button	Description
Default Style	Click to specify default report parameters for fonts and curve properties. <ul style="list-style-type: none"> • Font Type. Use to edit the font type and attributes for the selected item. Select an item in the list, click Edit, and select from various font options. • Thickness. Enter a thickness number for the curve. • Histogram Fill Style. Select a histogram fill option. • Graph border line thickness. Enter a thickness number for the graph border.
Delete	Deletes the selected report in the <i>Reports</i> list box. Deleted reports will have to be regenerated if deleted in error.
Hide	Hides (or temporarily removes) the selected report from the tabbed view. The report name remains in the <i>Reports</i> list box.
Print	Displays the <i>Print</i> window for report output. <ul style="list-style-type: none"> • Name drop-down list and Properties. Select the printer from the drop-down list and click Properties to change printer setup, etc. • Copies. Select the number of copies and collate option. • Current. Selects the active report (or selected tab). • All. Selects all reports in the <i>Reports</i> list box. • Shown. Selects only the reports not hidden. • Clear. Clears all selections.

Report Toolbar Fields and Buttons Table (continued)

Field or Button	Description
Reports list box	Contains a list of all generated reports. The same reports display as tabs at the top of the report header unless the report has been hidden using the Hide button.
Show	Displays the selected or hidden report in the <i>Reports</i> list box.
	For fields and buttons not listed in this table, see the <i>Common Fields and Buttons</i> section of this operator manual.

GRAPH FEATURES AND SHORTCUTS

Display graph report shortcuts by right clicking in the body of the graph report.

Autoscale	
Redraw	
Show Curve	
Hide curve	▶
Edit curve	▶
Edit axis	▶
Edit legend	
Edit title	
Copy as metafile	
Copy as text	

Graph Shortcuts Options and Description Table

Field or Button	Description
Autoscale	Returns the report to full view after using the zoom feature.
Copy as Metafile	Copies the report data as a metafile (.WMF)
Copy as Text	Copies the report data to the clipboard. It can then be pasted into other software programs as tab-delimited columns or copied as an overlay onto another graph.

Graph Shortcuts Options and Description Table (continued)

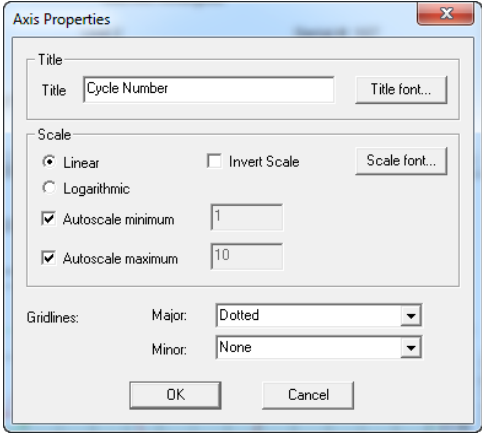
Field or Button	Description
Edit axis	<p>Use to edit the selected axis properties.</p>  <ul style="list-style-type: none"> • Title. Use to edit the selected axis label. • Title font. Use to modify the font for the selected axis label. Deselect the <i>Use default font</i> to enable font options. Select new font attributes for the report data. To return to the default fonts, enable <i>Use default font</i>. • Linear / Logarithmic. Select the option to scale the graph as linear or logarithmic. • Autoscale minimum / maximum. To manually specify minimum / maximum autoscale, deselect the option and enter the new amount in the text box. • Invert scale. Use to invert the scale. • Scale font. Use to modify the font for the scale label. Deselect <i>Use default font</i> to enable font options. • Grid lines. Use to change how to display major / minor grid lines.

Graph Shortcuts Options and Description Table (continued)

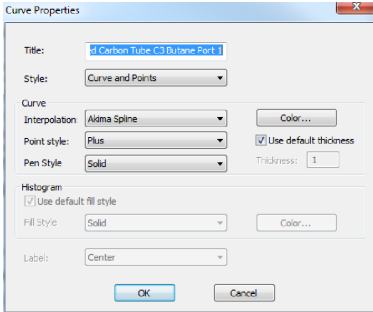
Field or Button	Description
<p>Edit curve</p>	<p>Use to edit selected curve properties.</p>  <ul style="list-style-type: none"> • Title. Use to change the title of the selected curve. • Style. Use to select another style for the collected data curve. • Curve group box. Use to change the interpolation, point style and pen style for the selected curve. These options are disabled if <i>Use default fill style</i> is selected in the <i>Histogram</i> group box. <p>Color. Click to change the curve color.</p> <p>Use default thickness. Uses the default curve thickness. Deselect to enter a new thickness number in the <i>Thickness</i> text box.</p> <ul style="list-style-type: none"> • Histogram group box. Enabled only if <i>Histogram</i> is selected in the <i>Style</i> drop-down list. Use to specify the type of fill, fill color and label position for the selected curve. • Label. Select where the graph point labels will display (left, right, center, etc.) on the SPC report.

Graph Shortcuts Options and Description Table (continued)

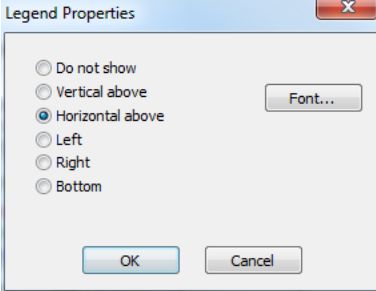
Field or Button	Description
Edit legend	<p>Use to change the legend location and font. Click Font to modify font attributes. Deselect the <i>Use default font</i> to enable font options. Select new font attributes for the report data. To return to the default fonts, enable <i>Use default font</i>.</p> 
Edit title	<p>Use to change the graph title and font. Click Font to font attributes. Deselect the <i>Use default font</i> to enable font options. Select new font attributes for the report data. To return to the default fonts, enable <i>Use default font</i>.</p>
Hide curve	<p>Hides selected curve.</p>
Redraw	<p>Sets the axis boundaries to the original view. This option also removes cross-hairs.</p>
Show curve	<p>Displays a list of all curves. Select the curve to display.</p>

Axis Cross-hair

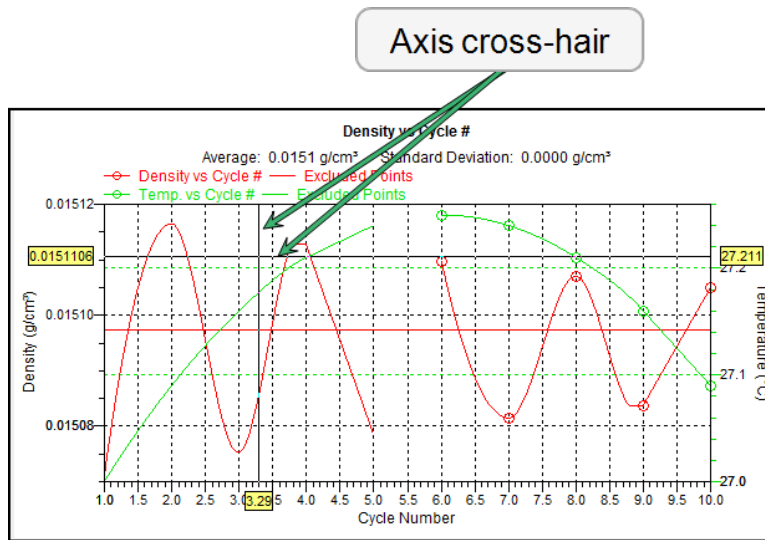

The cross-hair feature displays axis coordinates.

1. Left click on the graph to view the cross-hair coordinates.
2. To remove the cross-hair, right click in the graph area and select either *Autoscale all axes* or *Reset axis limits to initial setting*.

Graph Grid Lines

Options > Graph Grid Lines

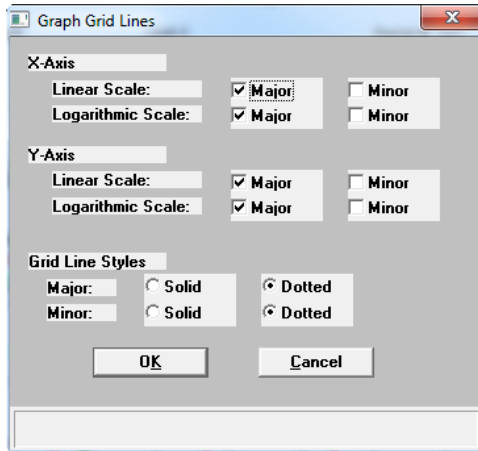

Use to select how grid lines appear on reports. This menu option is not available if using *Restricted* presentation option.

Graph Grid Lines Fields and Buttons Table

Field or Button	Description
Grid Line Styles	Select if the major and / or minor grid lines should appear as solid or dotted lines.
X-Axis / Y-Axis	Select major and / or minor lines to display in reports for the logarithmic and linear scales. Deselect this option to remove the grid lines.

Zoom Feature

Use the zoom feature to examine graph details.

1. Open the graph.
2. Hold down the left mouse button, then drag the mouse pointer across the graphical area to be enlarged. A box will display in the area to be enlarged.
3. Release the mouse button. The enlarged area fills the graph area. To return to normal view, right click in the graph area, then select either *Autoscale* or *Redraw* on the shortcut menu.

TABULAR REPORT FEATURES AND SHORTCUTS

Display tabular report shortcuts by right clicking in the body of the tabular report.

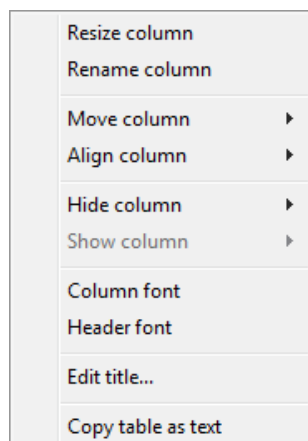

Tabular Reports Shortcut Options and Descriptions Table

Field or Button	Description
Align column	Change the column alignment to either left, right, or centered.
Column font	Change the column font. Deselect the <i>Use default font</i> to enable font options. Select new font attributes for the report data. To return to the default fonts, enable <i>Use default font</i> .
Copy table as text	Copy the report contents to the clipboard as tab-delimited text. It can then be pasted into another document.
Edit title	Change the report title in the tabular data area.
Header font	Change the column header font. Deselect the <i>Use default font</i> to enable font options. Select new font attributes for the report data. To return to the default fonts, enable <i>Use default font</i> .
Hide column	Hide the selected column.
Move column	Move the selected column left or right.
Rename column	Rename the selected column.
Resize column	Resize the width of the selected column.
Show column	Show a hidden column.

GRAPH OVERLAYS

Use the graph overlay functions to compare multiple graph options. Graphical lines are differentiated by the use of varying colored symbols outlined on a legend. Overlays may be generated in two ways:

- **Multiple Graph Overlays.** Overlay two different types of graphs from one sample.
- **Multiple Sample Overlays.** Overlay up to 8 graphs of the same type with that of the current plot.



This feature is available only when using *Advanced* presentation display.

GENERATING GRAPH OVERLAYS

Use graph overlays when graphically comparing results for multiple samples, or multiple graphs for one sample. Graphical lines are generated in different colors and denoted in a legend on the report.

Use the Advanced format to specify graph overlays. Graph overlays can be implemented in two ways:

- **Multiple Sample Overlays**
Overlay results for up to eight samples on top of a previously selected sample.
- **Multiple Graph Overlays**
Overlay two different types of graphs from one sample.

GENERATE MULTIPLE SAMPLE OVERLAYS



Use a copy of a file rather than the original file when performing a sample overlay.

1. Go to **Options > Option Presentation** and ensure there is a checkmark to the left of *Advanced*.
2. Go to **File > Open > Sample Information** and open the sample file.
3. On the *Report Options* tab, in the *Selected Reports* list box, select the reports to be used by double clicking the report name. This places a checkmark to the left of each selected report.
4. Highlight the graph to be used for multiple overlays, then click **Edit**.

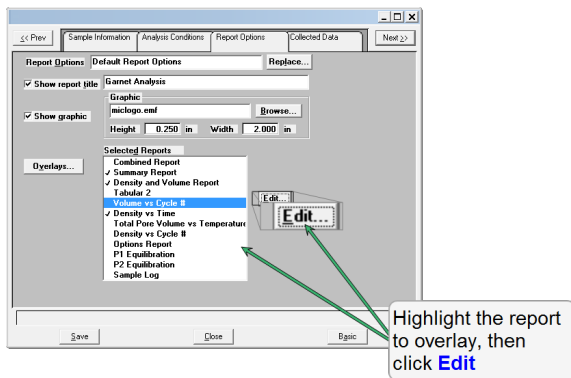

5. On the overlay window, click the down arrow to the right of the *Overlay* field and select the *Overlay Samples*. Select other options as needed, then Click **OK**.

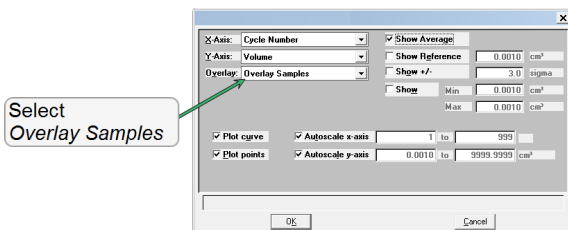

6. In the *Report Options* tab, click **Overlays**.

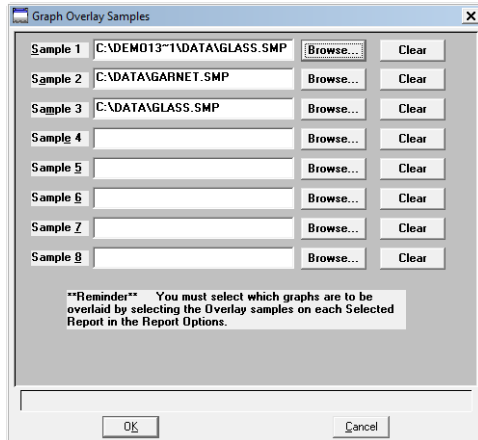

7. On the *Graph Overlays* window, click **Browse** to locate and select which graphs are to be overlaid. Click **OK**.
8. Go to **Reports > Start Report**. Select the report destination in the *Settings* group box. Select the overlay file name in the *Files* list box, then click **OK**.
9. In the pop-up *Selected Reports* list box, reports can be added or removed by double clicking the entry. Selected reports as indicated by a checkmark to the left. Click **OK**.
10. Reports display in a tabbed format. Click each tab to view each report.

GENERATE MULTIPLE GRAPH OVERLAYS

Multiple graph overlays can be generated by:

1. Go to **Options > Option Presentation** and ensure there is a checkmark to the left of *Advanced*.
2. Go to **File > Open > Sample Information** and open the sample file.
3. On the *Report Options* tab, in the *Selected Reports* list box, highlight the graph to be used for multiple overlays, then click **Edit**.

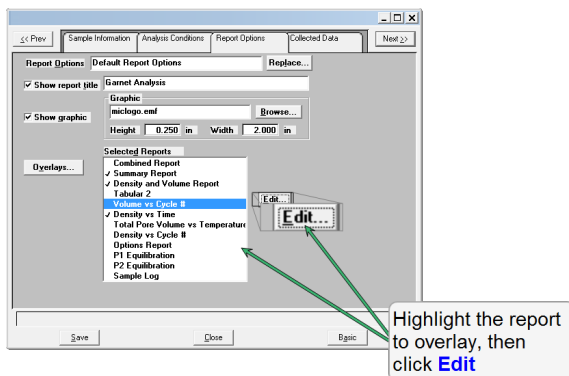

4. Click the down arrow to the right of the *Overlay* field and select a graph. This selection will overlay the graph selected in the *Y-axis* field.

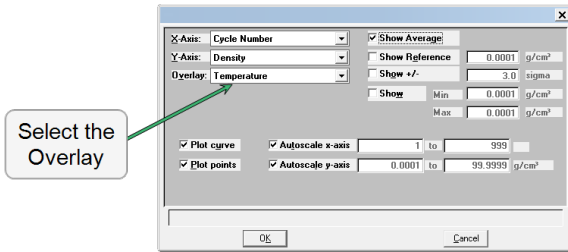

5. Click **OK** then click **Save**.
6. Go to **Reports > Start Report**. Select the report destination in the *Settings* group box. Select the overlay file name in the *Files* list box, then click **OK**.
7. In the pop-up *Selected Reports* list box, reports can be added or removed by double clicking the entry. Selected reports as indicated by a checkmark to the left. Click **OK**.
8. Reports display in a tabbed format. Click each tab to view each report.

SUMMARY REPORT EXAMPLE

			
4356 Communication Drive Norcross, GA 30093			
AccuPyc II 1340 FoamPyc V2.00	Unit 3	Serial #: 108	Page 1
Sample: Glass Powder Operator: HH Submitter: Micromeritics Bar Code: File: C:\DATA\GLASS.SMP			
Analysis Gas: Helium Reported: 11/26/2014 10:35:20AM Sample Mass: 5.9837 g Temperature: 23.79 °C Number of Purges: 10 Chamber Insert: None		Analysis Start: 1/22/2007 2:40:48PM Analysis End: 1/22/2007 3:12:00PM Equilib. Rate: 0.005 psig/min Expansion Volume: 9.1029 cm ³ Cell Volume: 11.2990 cm ³	
Comments: Sample 1			
Summary Report			
Sample Volume			
Average: 2.2428 cm ³			
Standard Deviation: 0.0015 cm ³			
Sample Density			
Average: 2.6591 g/cm ³			
Standard Deviation: 0.0018 g/cm ³			

TABULAR REPORT EXAMPLE

 4356 Communication Drive Norcross, GA 30093						
AccuPyc II 1340 FoamPyc V2.00	Unit 3	Serial #: 108	Page 2			
Sample: Glass Powder Operator: HH Submitter: Micromeritics Bar Code: File: C:\DATA\GLASS.SMP						
Analysis Gas: Helium Reported: 11/26/2014 10:35:20AM Sample Mass: 5.9637 g Temperature: 23.79 °C Number of Purges: 10 Chamber Insert: None			Analysis Start: 1/22/2007 2:40:48PM Analysis End: 1/22/2007 3:12:00PM Equilib. Rate: 0.005 psig/min Expansion Volume: 9.1029 cm ³ Cell Volume: 11.2990 cm ³			
Comments: Sample 1						
Density and Volume Report						
Cycle#	Volume (cm ³)	P2 Pressure Deviation (psig)	Density (g/cm ³)	Volume Deviation (cm ³)	Temperature (°C)	Porosity* (%)
1	2.2418	-0.017	2.6602	-0.0010	23.72	62.41
2	2.2446	-0.006	2.6569	0.0018	23.74	62.36
3	2.2410	-0.028	2.6612	-0.0018	23.75	62.42
4	2.2408	-0.014	2.6614	-0.0019	23.77	62.43
5	2.2423	-0.012	2.6596	-0.0005	23.78	62.40
6	2.2437	0.002	2.6580	0.0009	23.80	62.38
7	2.2434	0.032	2.6584	0.0006	23.83	62.38
8	2.2457	0.027	2.6557	0.0029	23.83	62.34
9	2.2417	0.013	2.6603	-0.0011	23.85	62.41
10	2.2428	0.004	2.6590	0.0001	23.87	62.39
Summary Data			Average	Standard Deviation		
Volume:			2.2428 cm ³	0.0015 cm ³		
Density:			2.6591 g/cm ³	0.0018 g/cm ³		
*Calculated from envelope density						

GRAPH REPORT EXAMPLE

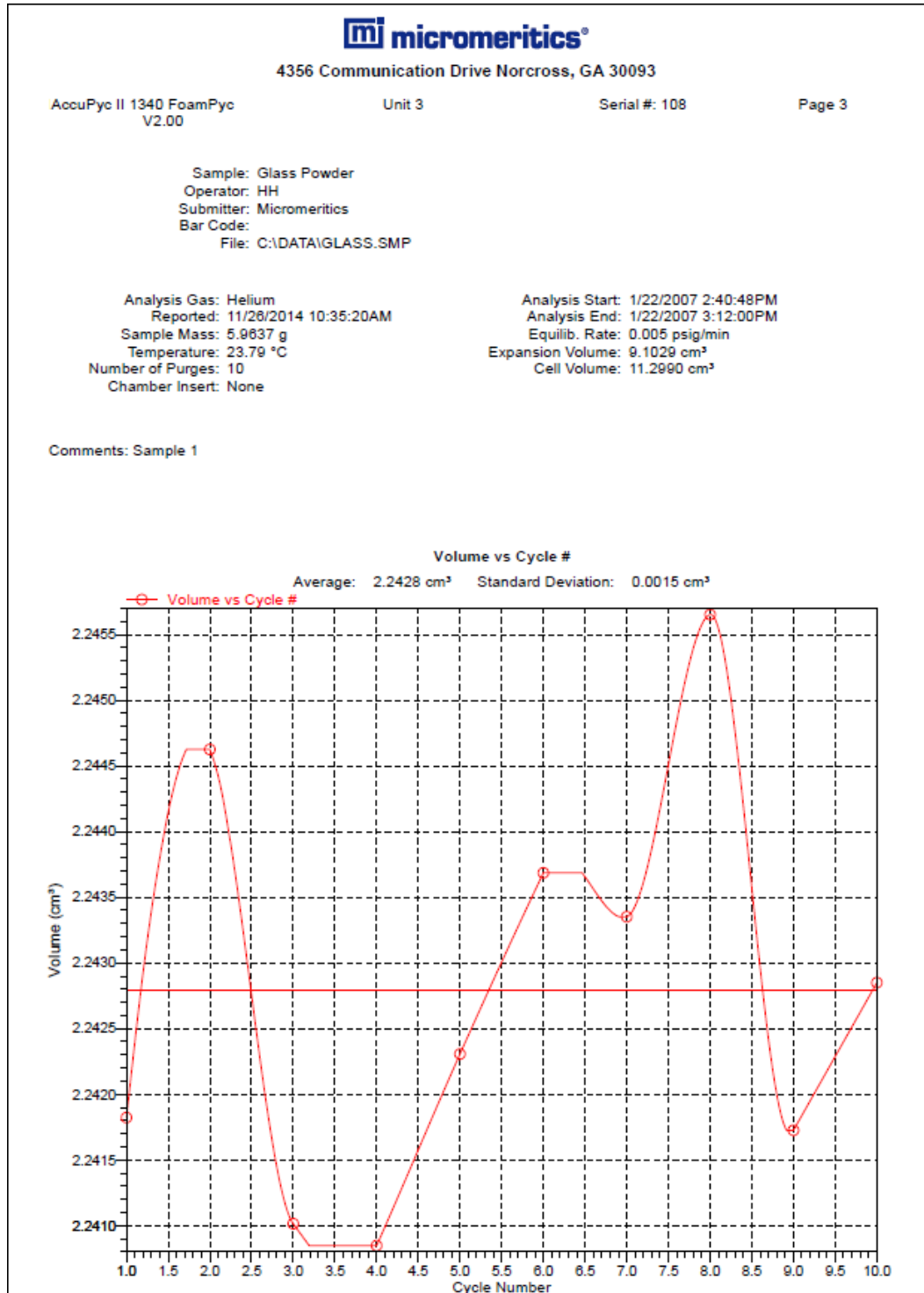

OVERLAY REPORT EXAMPLE

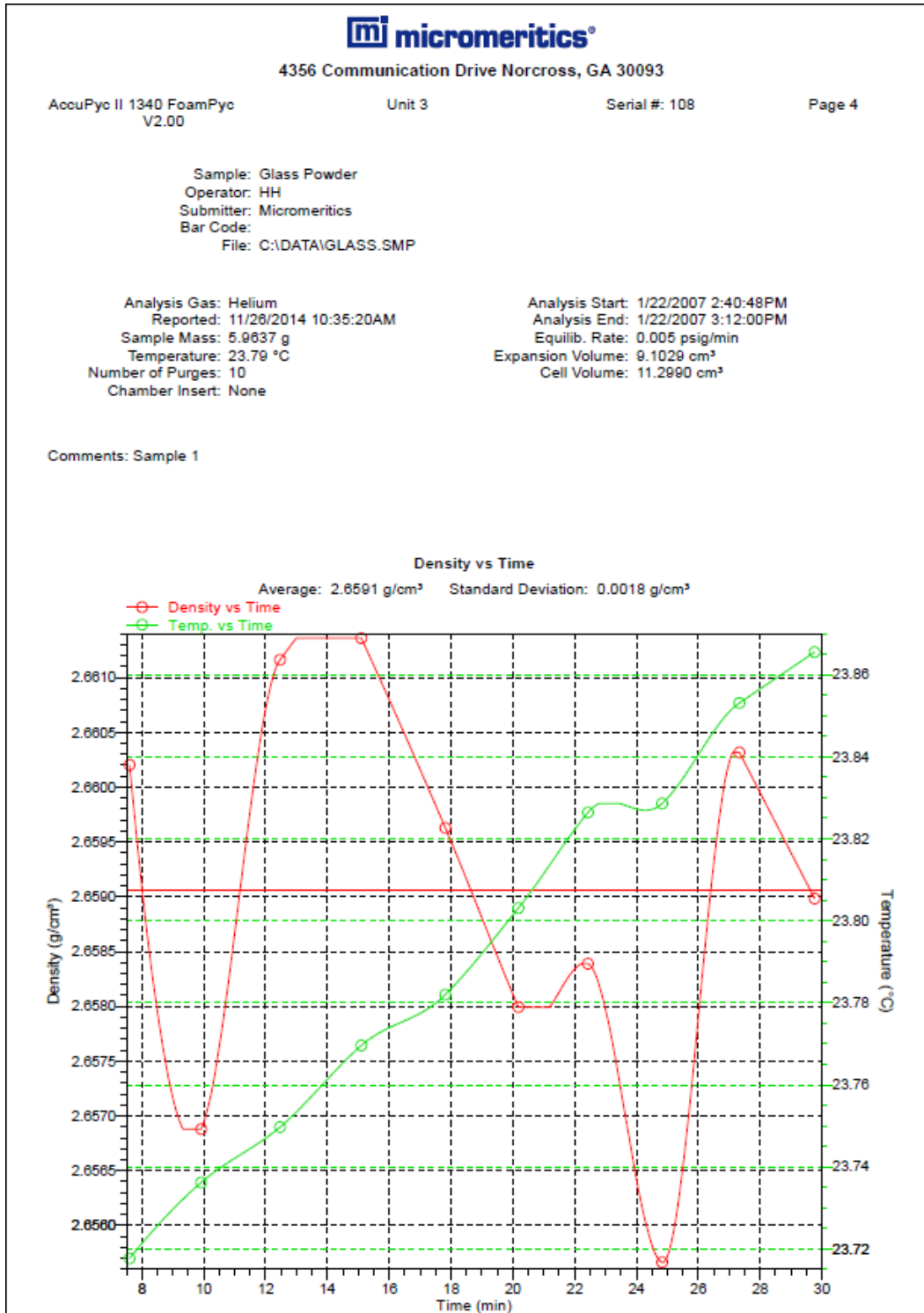

EQUILIBRATION REPORT EXAMPLE

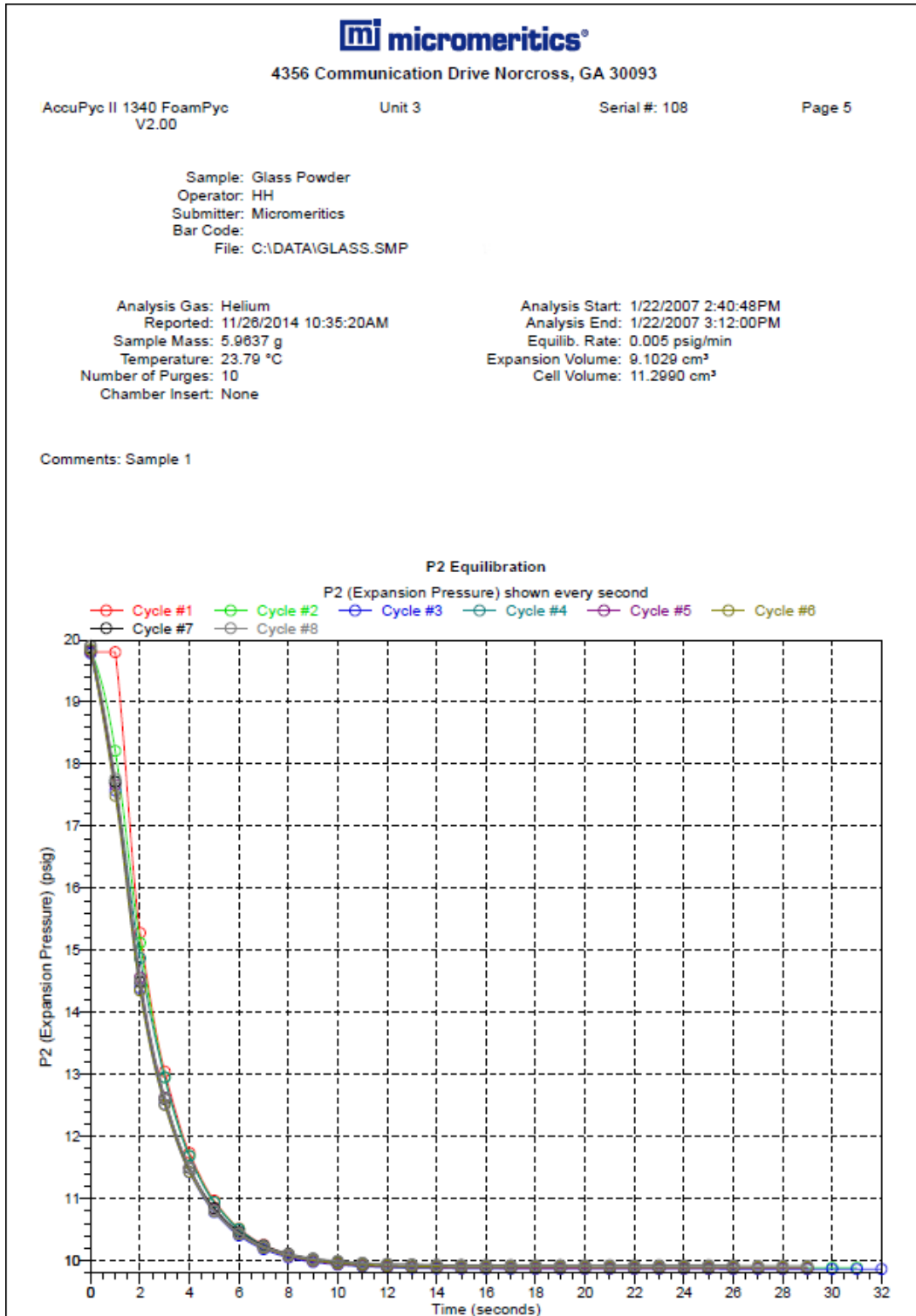

SAMPLE LOG EXAMPLE



4356 Communications Drive Norcross, GA 30093

AccuPyc II 1340 Asphalt V2.00 Unit 1 Serial #: 2366 Page 1

Sample: S/N 2366 1cc Volume Check
 Operator: AL
 Submitter: MAS
 Bar Code: Sphere Volume = 0.717913 - 0.719141
 File: C:\DATA\1406472C.SMP

Analysis Gas: Nitrogen Analysis Start: 9/2/2014 7:54:30AM
 Reported: 10/7/2014 1:36:57PM Analysis End: 9/2/2014 8:34:14AM
 Sample Mass: 1.0000 g Equilib. Rate: 0.005 psig/min
 Temperature: 23.22 °C Expansion Volume: 0.8697 cm³
 Number of Purges: 10 Cell Volume: 1.3300 cm³
 Chamber Insert: None

Comments: Total number of pages: 1

Sample log		
Date	Time	Log Message
9/2/2014	7:54:30AM	Analysis started.
9/2/2014	8:34:14AM	Analysis done.

8 SELECTED REPORTS

COMBINED REPORT

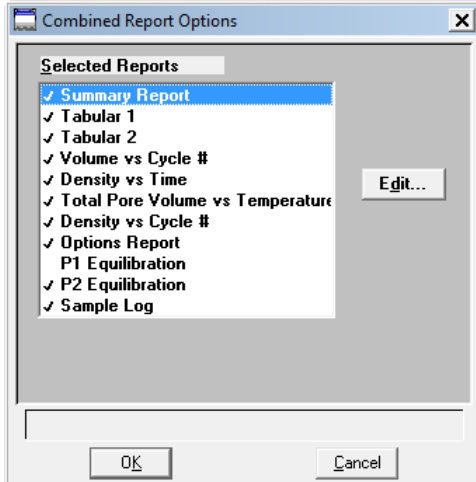

The *Combined Reports* option creates a single report from all selected reports. The *Combined Report* contains no breaks between reports and no headings. Highlight the report, then click **Edit** to edit report details.

DENSITY AND VOLUME TABLE

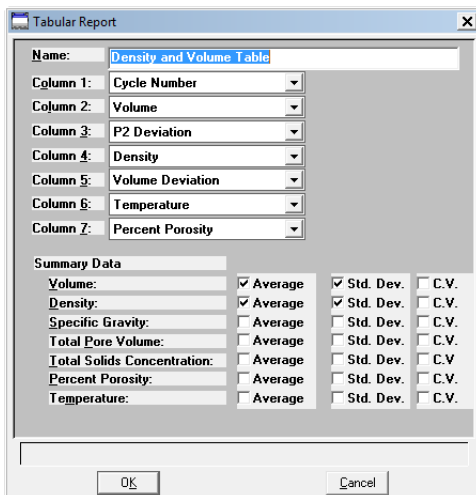

Density and Volume Fields and Buttons Table

Field or Button	Description
Columns 1 through 7	Select a variable for each column.
Name	Enter the name of the report.
Summary Data	Select the average, standard deviation, and coefficient of variation (C.V.) for report parameters.
 <p>For fields and buttons not listed in this table, see the <i>Common Fields and Buttons</i> section of this operator manual.</p>	

DENSITY VS CYCLE NUMBER TREND PLOT

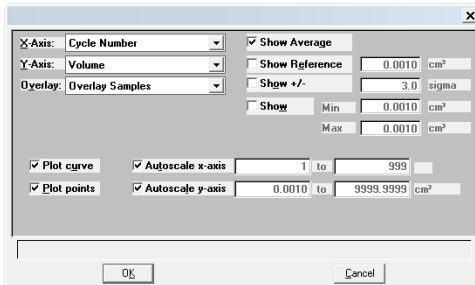

There are four types of graphical reports available. Report titles are based on the parameters selected for the X-axis and Y-axis.

Volume vs Cycle Number Trend Plot Fields and Buttons Table

Field or Button	Description
Autoscale x-axis Autoscale y-axis	When enabled on the report parameters windows, allows the x- and y-axes to be scaled automatically. <i>Autoscale</i> means that the x- and y-ranges will be set so that all the data is shown. If <i>Autoscale</i> is not selected, the entered range is used.
Overlay	Select overlay plot options. <ul style="list-style-type: none"> A second Y-axis can be selected to overlay with the variable in the Y-Axis field. <p>or</p> <ul style="list-style-type: none"> Select <i>Overlay Samples</i> to overlay data of the type selected in the <i>Y-Axis</i> field with the same type of data contained in other sample files. To select other sample files, go to the <i>Report Options</i> tab and click the Overlays button.

Volume vs Cycle Number Trend Plot Fields and Buttons Table (continued)

Field or Button	Description
Plot curve Plot points	Select to display how data are plotted.
Show +/-	Select to place two horizontal lines on the graph. The top line will be placed at a point relative to the average and standard deviation of the data. The bottom line will be placed at the point entered in the adjacent field.
Show Average	Select to show the average of all cycles. A horizontal line is placed at the average point for the cycles.
Show Min Show Max	Select to show the average of all cycles. Horizontal lines are placed at the entered limits.
Show Reference	Select to show a horizontal line placed at a reference point specified in the adjacent field.
X-Axis	Variables available for the X-axis.
Y-Axis	Variables available for the Y-axis.
 For fields and buttons not listed in this table, see the <i>Common Fields and Buttons</i> section of this operator manual.	

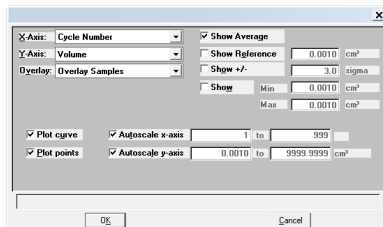
DENSITY VS TIME TREND PLOT

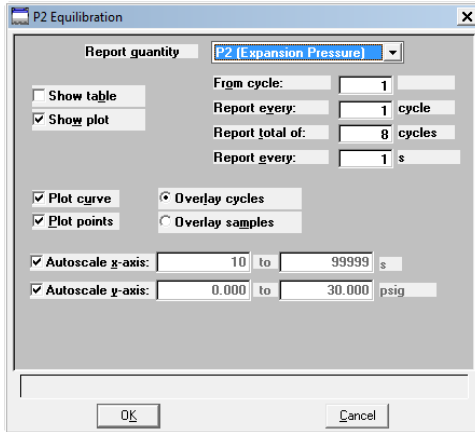

The *Density vs Cycle Number Trend Plot* and the *Volume vs Cycle Number* are identical unless otherwise noted.. See ["Density vs Cycle Number Trend Plot" on the previous page.](#)

EQUILIBRATION REPORT



This report is available only if the *Record equilibration data* option was selected on the *Analysis Conditions* tab.

Equilibration Report Fields and Buttons Table

Field or Button	Description
Autoscale x-axis Autoscale y-axis	When enabled on the report parameters windows, allows the x- and y-axes to be scaled automatically. <i>Autoscale</i> means that the x- and y-ranges will be set so that all the data is shown. If <i>Autoscale</i> is not selected, the entered range is used.
From cycle	Enter the beginning report cycle.
Report every	Enter which cycle to report.
Overlay cycles	Select to overlay the number of cycles entered in the <i>Report total of</i> field.
Overlay samples	Select to overlay the last cycle in the current file with the last cycle contained in other files. Click Overlays on the <i>Report Options</i> tab to select the other sample files.
Plot curve Plot points	Select to display how data are plotted.
Report quantity	Select a variable to be reported.
Report total of	Enter the number of cycles for this report. Enter up to 8 cycles.
Report every	Enter time between cycles. Up to 60 seconds can be entered.
Show plot	Generates a plot (graph) for the <i>Report quantity</i> field selection.
Show table	Generates a tabular report for the <i>Report quantity</i> field selection.
	For fields and buttons not listed in this table, see the <i>Common Fields and Buttons</i> section of this operator manual.

OPTIONS REPORT

The *Options* report provides information on the sample, its material properties, and analysis conditions. This report cannot be edited.

PRESSURE AND VOLUME TABLE

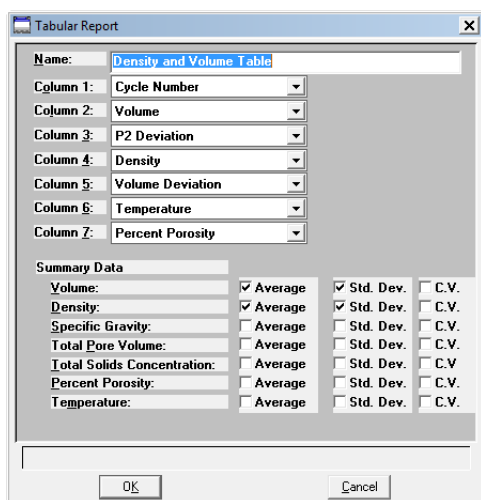

Tabular Report

Name:

Column 1:

Column 2:

Column 3:

Column 4:

Column 5:

Column 6:

Column 7:

Summary Data

Volume:	<input checked="" type="checkbox"/> Average	<input checked="" type="checkbox"/> Std. Dev.	<input type="checkbox"/> C.V.
Density:	<input checked="" type="checkbox"/> Average	<input checked="" type="checkbox"/> Std. Dev.	<input type="checkbox"/> C.V.
Specific Gravity:	<input type="checkbox"/> Average	<input type="checkbox"/> Std. Dev.	<input type="checkbox"/> C.V.
Total Pore Volume:	<input type="checkbox"/> Average	<input type="checkbox"/> Std. Dev.	<input type="checkbox"/> C.V.
Total Solids Concentration:	<input type="checkbox"/> Average	<input type="checkbox"/> Std. Dev.	<input type="checkbox"/> C.V.
Percent Porosity:	<input type="checkbox"/> Average	<input type="checkbox"/> Std. Dev.	<input type="checkbox"/> C.V.
Temperature:	<input type="checkbox"/> Average	<input type="checkbox"/> Std. Dev.	<input type="checkbox"/> C.V.

OK Cancel

The *Pressure and Volume Table* and the *Density and Volume Table* are identical unless otherwise noted. See ["*Density and Volume Table*" on page 8 - 1.](#)

SAMPLE LOG REPORT

The Sample Log report displays:

- Automatic operations
- Information entered using **Add Log Entry** on the *Sample Information* tab
- Warnings and / or errors which occurred during analysis

The *Sample Log Report* cannot be edited.

SUMMARY REPORT

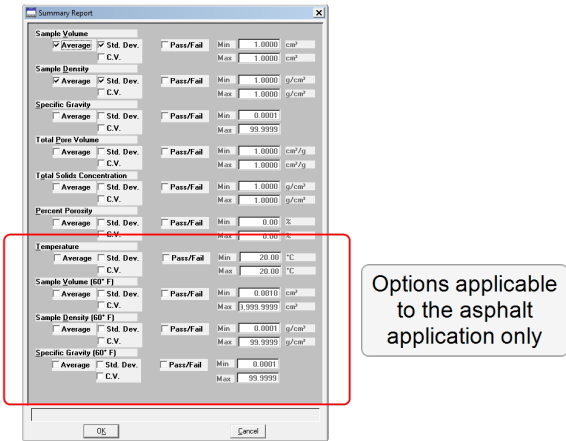

The *Summary Report* provides a condensed listing of data results. Select the type of information to include in the report. If *Pass/Fail* is selected, the *Min* and *Max* fields are enabled. Enter the minimum and maximum values for the pass / fail.

TABULAR REPORT

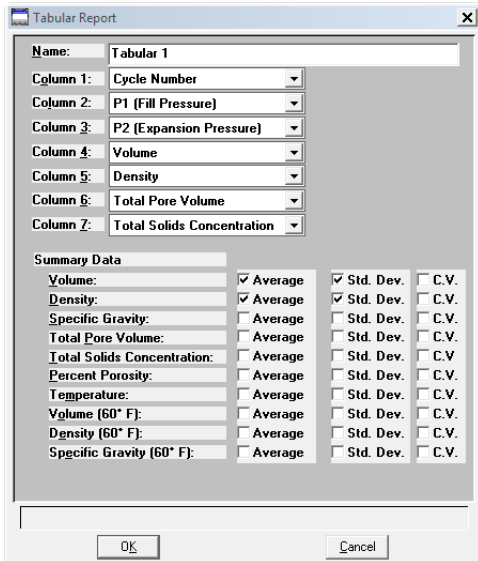

Tabular Report Fields and Buttons Table

Field or Button	Description
Columns 1 through 7	Select a variable to appear in each column. Selections applicable only to the Asphalt configuration: <ul style="list-style-type: none"> • Volume (60 °F) • Density (60 °F) • Specific Gravity (60 °F) • Volume (60 °F) Deviation • Density (60 °F) Deviation • Specific Gravity (60 °F) Deviation
Name	Enter a name for the report.
Summary Data	Select options for reporting the average, standard deviation, and coefficient of variation (C.V.).
 For fields and buttons not listed in this table, see the <i>Common Fields and Buttons</i> section of this operator manual.	

TOTAL PORE VOLUME VS TEMPERATURE

The *Total Pore Volume vs Temperature* and the *Density vs Cycle Number Trend Plot* are identical unless otherwise noted. See ["Density vs Cycle Number Trend Plot" on page 8 - 2.](#)

VOLUME VS CYCLE NUMBER TREND PLOT

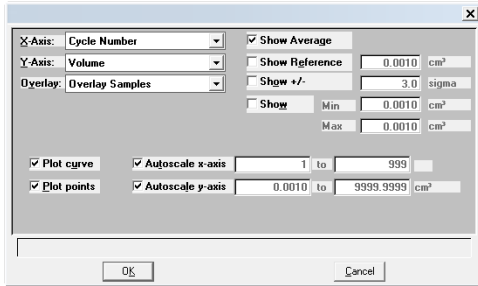

X-Axis:	Cycle Number	<input checked="" type="checkbox"/> Show Average	
Y-Axis:	Volume	<input type="checkbox"/> Show Reference	0.0010 cm ³
Overlay:	Overlay 5 samples	<input type="checkbox"/> Show +/-	3.0 sigma
		<input type="checkbox"/> Show	Min: 0.0010 cm ³ Max: 0.0010 cm ³
<input checked="" type="checkbox"/> Plot curve	<input checked="" type="checkbox"/> Autoscale x-axis		1 to 999
<input checked="" type="checkbox"/> Plot points	<input checked="" type="checkbox"/> Autoscale y-axis		0.0010 to 9999.9999 cm ³

The *Volume vs Cycle Number* and the *Density vs Cycle Number Trend Plot* are identical unless otherwise noted. See ["Density vs Cycle Number Trend Plot" on page 8 - 2.](#)

9 DIAGNOSTICS USING THE SOFTWARE

Unit [n] > Diagnostics

Performs a leak test for the analysis module.

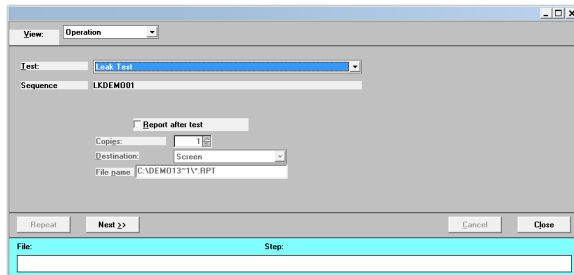

Diagnostic Test Fields and Buttons Table

Field or Button	Description
File	Shows a status bar of steps complete once the test begins.
Next	Starts the next test.
Report after test	Automatically generates reports to the selected destination when the test is complete.
Sequence	Sequence number assigned to the test.
Test	Select the test from the drop-down list.
	For fields and buttons not listed in this table, see the <i>Common Fields and Buttons</i> section of this operator manual.

Blank Page

10 CALIBRATION

The pycnometer volume should be calibrated every time it is restarted. Cell volume and expansion volume in the set up parameters are updated automatically upon calibration. Run an analysis with an empty cup to see how close the average volume is to 0. It should be $\pm 0.05\%$ of full scale. If it is not within $\pm 0.05\%$ of full scale, calibration is required.

If calibrating using the keypad, see ["Calibrate using the Keypad" on page 10 - 14](#).

CALIBRATE USING THE SOFTWARE

CALIBRATION REPORT

Unit [n] > Calibration > Calibration Report

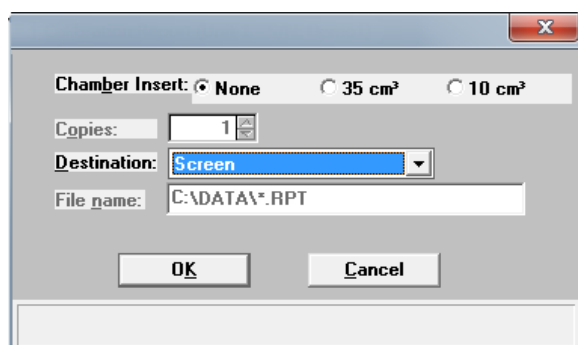

1. Select the type of chamber insert used.
2. Select the report destination.
3. Click **OK** to generate the report.

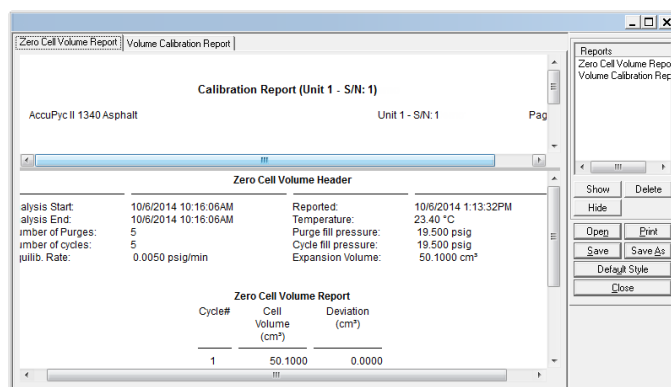

CALIBRATE TEMPERATURE OFFSET

Unit [n] > Calibration > Temperature

Opens the *Calibrate Temperature Offset* box.

Calibrates the temperature offset. Use an external reference device to determine the sample cell temperature. Enter the value in the field, then click **Done**.

A Calibration report is not generated for the temperature offset. The entry is recorded in the *Instrument Log*. To view the log, go to **Unit [n] > Show Instrument Log**.

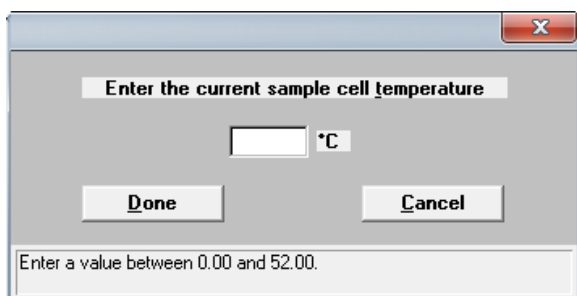

Enter the current sample cell temperature

°C

Done **Cancel**

Enter a value between 0.00 and 52.00.

1. Enter the current sample cell temperature.
2. Click **Done**. Temperature reading will be adjusted to the entered temperature.

CALIBRATE ZERO CELL VOLUME

Unit [n] > Calibration > Zero Cell Volume

Use to calibrate the cell volume offset.

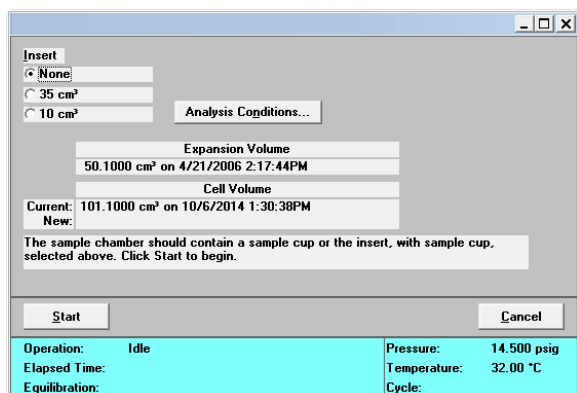

Insert

None

35 cm³

10 cm³

Analysis Conditions...

Expansion Volume

50.1000 cm³ on 4/21/2006 2:17:44PM

Cell Volume



Current: 101.1000 cm³ on 10/6/2014 1:30:38PM

New:

The sample chamber should contain a sample cup or the insert, with sample cup, selected above. Click Start to begin.

Start **Cancel**

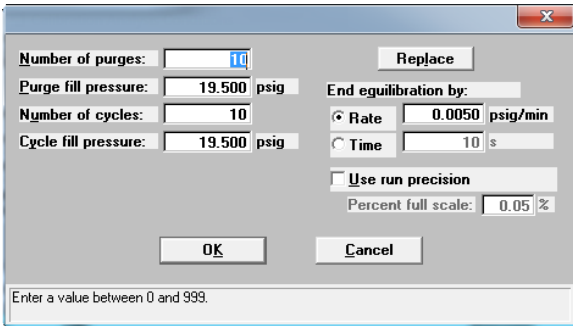
Operation:	Idle	Pressure:	14.500 psig
Elapsed Time:		Temperature:	32.00 °C
Equilibration:		Cycle:	

Field or Button	Description
Analysis Conditions	Specify conditions for the calibration.  Click Replace to replace the values with those from an existing <i>Analysis Conditions</i> file. See "Analysis Conditions" on page 5 - 2 .
Cell Volume	Current cell volume (without an insert) or the volume of the selected insert.
Expansion Volume	Current expansion volume, and the date and time of calibration.
 Insert values listed in this table are default values. The insert title can be changed by the user by clicking <i>Unit > Unit Configuration</i> and changing the Insert title.	
Insert 1 cm ³ unit	<ul style="list-style-type: none"> • None • 0.1 cm³ If <i>None</i> is selected, place an empty sample cup in the chamber.
Insert 10 cm ³ unit	<ul style="list-style-type: none"> • None • 3.5 cm³ If <i>None</i> is selected, place an empty sample cup in the chamber.
Insert 1.0 cm ³ and 100 cm ³ unit	<ul style="list-style-type: none"> • None • 35 cm³ • 10 cm³ If <i>None</i> is selected, place an empty sample cup in the chamber.
Insert 350 cm ³ and 2000 cm ³ units	<ul style="list-style-type: none"> • None • Large • Small If <i>None</i> is selected, place an empty sample cup in the chamber.

Field or Button	Description
	For fields and buttons not listed in this table, see the <i>Common Fields and Buttons</i> section of this operator manual.

CALIBRATE ZERO PRESSURE

Unit [n] > Calibration > Zero Pressure

This option zeros the pressure transducer reading.

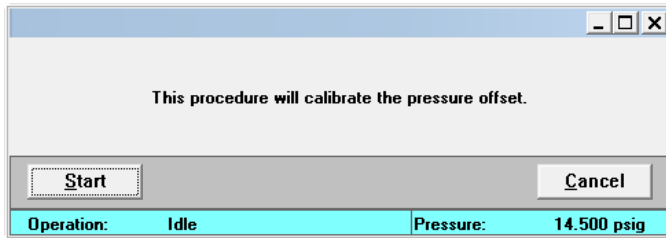

Click **Start** to calibrate the pressure offset.

RESET PRESSURE CALIBRATION

Unit [n] > Calibration > Reset Pressure Calibration

This procedure resets the pressure calibration to the factory default settings.

This option can be used when the pressure appears not to be reported correctly by the analyzer. For example: a zero, negative, or unreasonably high reading is being consistently reported. Resetting to nominal may restore normal pressure readings but a proper calibration should be performed.

A popup warning indicates that when this option is used, the previous pressure calibration is lost and the nominal calibration is used.

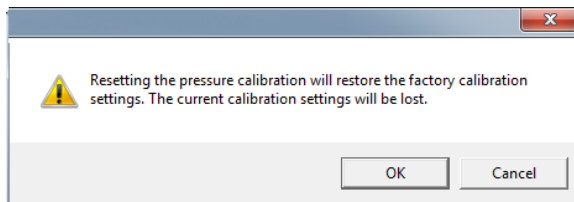

Temperature and volume calibrations are not affected by a reset of the pressure calibration.

Click **OK**. The nominal calibrations may be sufficient. However, it is recommended to contact your Micromeritics Service Representative and schedule a proper pressure calibration as soon as possible since data accuracy may be compromised.

CALIBRATE VOLUME SCALE

Unit [n] > Calibration > Calibrate Volume

Calibrates the cell volume offset and expansion volume.

Although the instrument is calibrated prior to shipment, the pycnometer should be recalibrated to laboratory atmospheric and environmental conditions.

1. On the pressure regulator, turn the pressure control knob clockwise to set the regulator pressure at 21.500 psig (low pressure gauge).

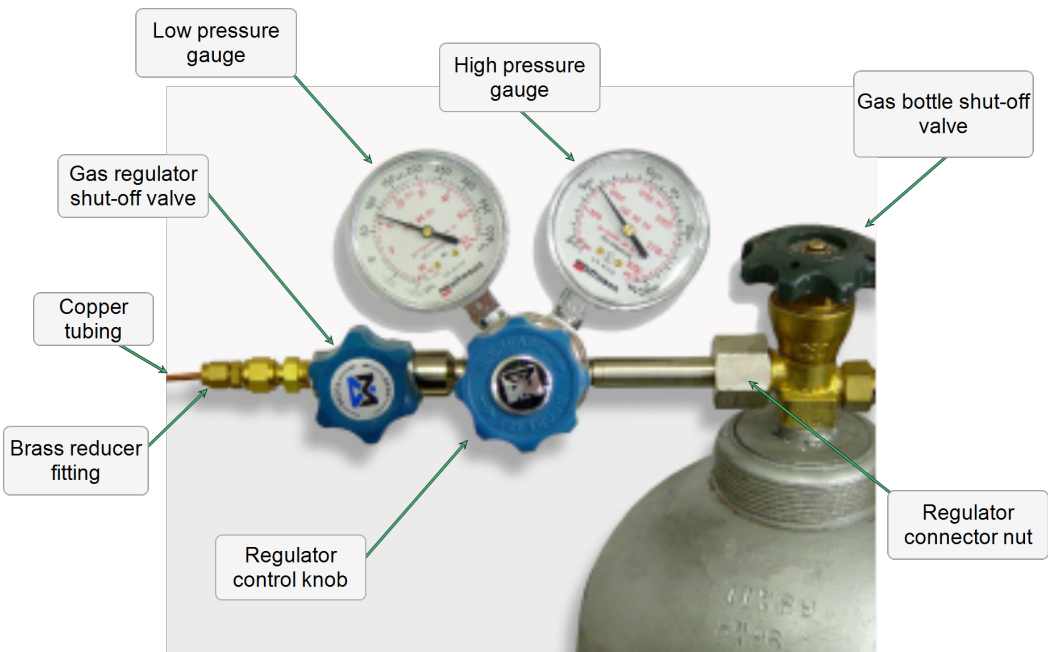

2. Remove the chamber cap and place an empty cup into the sample chamber, then replace the cap. If an insert is being used, place the insert sample cup into the chamber.



Wear latex or nitrile, powder-free gloves to prevent transfer of oil from hands when handling sample cups, calibration standards, and inserts. See ["Handling System Components" on page J - 1.](#)

3. Go to **Unit [n] > Calibration > Calibrate Volume.**

4. Enter the volume of the calibration standard (located on the outside of the calibration standards case shipped with the instrument) in the *Volume of Calibration Standard* field.

The value recorded on the case for a 10 cm³ pycnometer is the sum of the two standards, and on a 350 cm³ pycnometer, the sum of the three standards.

5. Select the *Measured* option.
6. Click **Analysis Conditions** to specify calibration parameters. Click **Replace** and select the file *calstd.anc*. The values in the current file will be replaced with those contained in the selected file. Click **OK**, then click **OK** again to return to the *Calibrate Volume Scale* window.

7. Click **Start** to begin the first phase of the calibration (volume offset). Status messages display until this phase is complete. When the phase has finished, a prompt display indicates to insert the calibration standard.
8. Remove the sample chamber cap, then remove the sample cup from the chamber. Place the cap back onto the chamber while placing the standard into the cup.
9. Tilt the sample cup and allow the standard to roll gently into the cup to prevent denting of the cup.

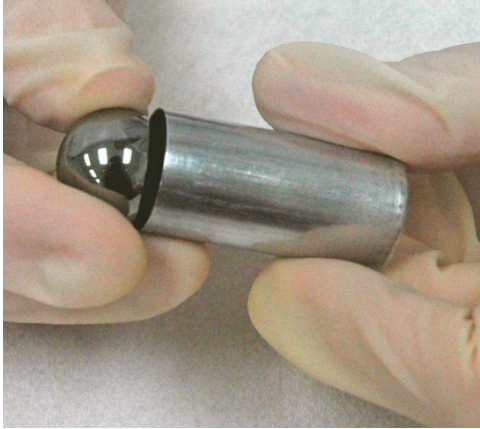

- one standard is shipped with the 1-, 100-, and 2000 cm³ pycnometers
 - two are shipped with the 10 cm³ pycnometer
 - three are shipped with the 350 cm³ pycnometer
10. Remove the sample chamber cap, place the sample cup back into the chamber, and replace the cap. Turn the cap clockwise to tighten.
 11. Allow the standards to reach thermal equilibrium with the pycnometer.
 - Wait 10 minutes for 1- and 10 cm³ pycnometer
 - Wait 15 minutes for the 100 cm³ pycnometer
 - Wait 20 minutes for the 350 cm³ pycnometer
 - 30 minutes for the 2000 cm³ pycnometer
 12. Click **Continue** to complete the second phase of the calibration (volume scale). Status messages display until the calibration is complete.
 13. Click **Done** to accept the new values, then click **OK**.
 14. Do not remove the standard from the sample chamber until the operation is verified. See [*"Verify Operation" on page 10 - 10.*](#)

Calibrate Volume Scale Fields and Buttons Table

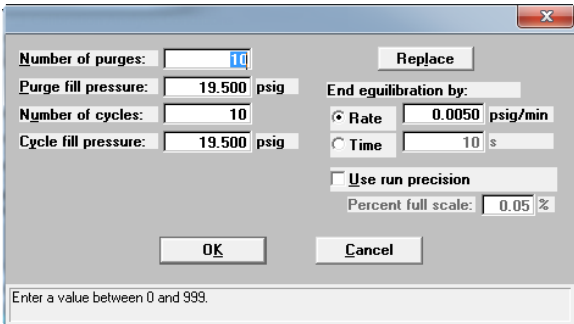
Field or Button	Description
Analysis Conditions	<p>Specify conditions for the calibration.</p>  <p>Click Replace to replace the values with those from an existing Analysis Conditions file.</p>
Cell Volume	Displays the current cell volume (without an insert), or the volume of the selected insert.
Continue	Place the standard into the sample cup and click Continue to complete the volume scale calibration.
Expansion Volume	Displays the current expansion volume, and the date and time of calibration.
Insert	<ul style="list-style-type: none"> • 1 cm³ unit None, 0.1 cm³ • 10 cm³ unit None, 3.5 cm³ • 1.0 cm³ 100 cm³ unit None, 35 cm³, 10 cm³ • 350 cm³ and 2000 cm³ units None, Large, Small <p>If <i>None</i> is selected, place an empty sample cup in the chamber.</p>
Previously Entered / Measured	<p>Select the method for calibrating the cell and expansion volumes.</p> <ul style="list-style-type: none"> • Previous. Uses the current values. • Entered. Enables the fields for the cell and expansion volumes. • Measured. Measure the cell and expansion volumes using a reference standard.
Start	Begins the first segment of the volume offset calibration. Status messages are shown as the calibration proceeds. When the volume offset calibration is complete, a prompt displays indicating to insert the standard.
Volume of Calibration Standard	The volume of the standard used for the previous calibration.

Calibrate Volume Scale Fields and Buttons Table (continued)

Field or Button	Description
	For fields and buttons not listed in this table, see the <i>Common Fields and Buttons</i> section of this operator manual.

VERIFY OPERATION

Verify operation of the pycnometer by performing an analysis on the calibration standard to ensure that the pycnometer is operating properly.

1. Go to **Unit [n] > Sample Analysis**.
2. Click **OK**, then **Yes** to create a new sample file.
3. Click **Replace** and select the *refanly.smp* file. The values in the current file will be replaced with those contained in *refanly.smp*. Click **OK**.

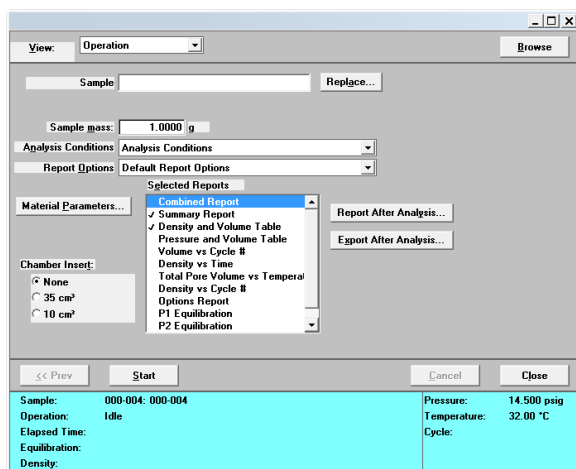

4. Click **Report After Analysis**. Select the *Report after analysis* option, then click **OK**.

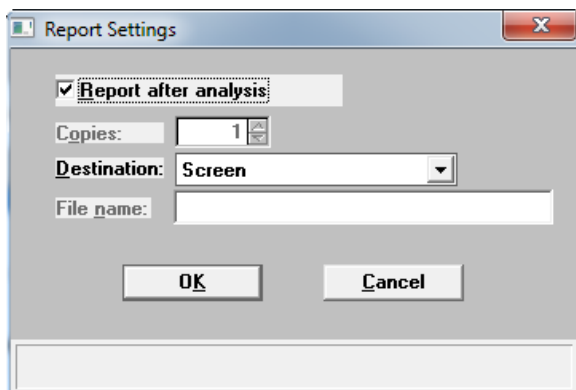

5. Click **Start** to begin the analysis.
6. Compare the value displayed for the average volume to the value recorded on the calibration standards case. These two values should agree plus or minus the tolerance obtained using the following calculation:

$$\text{Tolerance} = (\text{chamber volume} * 0.0003) + (\text{Value recorded on Standards case} * 0.0003)$$

Example: calculate the tolerance for a 10 cm³ pycnometer with a value of 6.372242 recorded on the case as :

$$\text{Tolerance} = (10 * 0.0003) + (6.372242 * 0.0003) = 0.003 + 0.0019116726 = 0.005$$

If the values do not agree, a leak may be indicated. Check the system for leaks. Then repeat steps 1 through 6. If the values continue to disagree, contact your Micromeritics service representative. See [*"Diagnostics using the Software" on page 9 - 1.*](#)

7. Remove the standards and place them back into the case.

LOAD CALIBRATION FROM FILE

Unit [n] > Calibration > Load from File

Use to load a previously saved calibration file.

It is recommended that the current calibration settings be saved using **Unit [n] > Calibration > Save to File** prior to loading another calibration file. When loading a previously saved calibration file, a backup of the current file is created and saved as *[SN]last.cal*. The backup file is overwritten each time a new one is created.



Changing the calibration may affect the analyzer's performance.

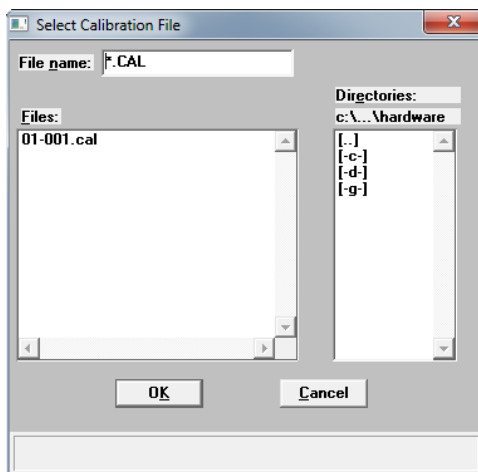

1. Select the calibration file from the *Files* list box.
2. Click **OK**.

SAVE CALIBRATION TO FILE

Unit [n] > Calibration > Save to File

Use to save the current calibration settings to a backup file which can later be reloaded using **Unit [n] > Calibration > Load from File** menu option.

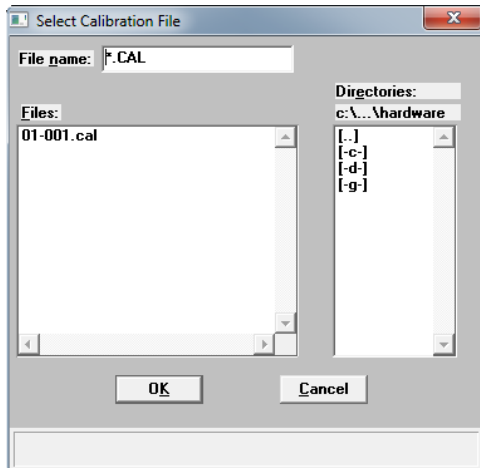

The default file naming convention for calibration files can be used or the file name can be changed. The default file name of 0217-001.CAL is interpreted as:

0217	is the analyzer serial number
001	is the sequence number
.CAL	is the file name extension

CALIBRATE USING THE KEYPAD

CALIBRATE FUNCTION

This command performs a full volume slope and offset calibration. Press **ALT + . (decimal)** to access the *Calibrate* function.

Display Text	Description
Calibration Type? Volume	Press CHOICE until the option is displayed, then press ENTER . <ul style="list-style-type: none"> • Volume • Temperature • Pressure • Copy to an external device • Load from an external device • Reset Pressure Calibration

CALIBRATION DATA

Display Text	Description
Setup Type? Calibration Data	Press CHOICE until <i>Calibration Data</i> is displayed, then press ENTER .
Calibration Data Chamber Insert?	Select Yes at the <i>Request insert</i> prompt in <i>Report Options</i> . Press CHOICE until the appropriate insert is displayed, then press ENTER . <ul style="list-style-type: none"> • None, 0.1 cm³ (for 1 cm³ unit) • None, 3.5 cm³, 1.0 cm³ (for 10 cm³ unit) • None, 35 cm³, 10.0 cm³ (for 100 cm³ unit) • None, 650 cm³, 1300 cm³ (for 2000 cm³ pycnometer)
Calibration Data Cell Volume:	Displays the cell volume determined during calibration. Cell volumes can also be entered at this prompt. Press ENTER . The range is 0.01 to 999.0000 cm ³ .
Calibration Data Expansion Volume:	Displays the expansion volume determined during calibration. Press ENTER . The range is 0.5 to 999.0000 cm ³ .

CALIBRATE VOLUME

Place an empty cup into the sample chamber for **Cal1** (volume offset). If using an insert, place the insert and its appropriate sample cup into the sample chamber.

Display Text	Description
Calibration Type? Volume	Press ENTER to accept <i>Volume</i> (default) and display the next prompt.
Calibrate Volume Chamber insert?	<p>Press CHOICE until the appropriate insert is displayed, then press ENTER. Yes must be selected for the <i>Request Insert</i> prompt in <i>Report Options</i> for this prompt to display.</p> <ul style="list-style-type: none"> • None, 0.1 cm³ (for 1 cm³ unit) • None, 3.5 cm³, 1.0 cm³ (for 10 cm³ unit) • None, 35 cm³, 10.0 cm³ (for 100 cm³ unit) • None, 650 cm³, 1300 cm³ (for 2000 cm³ pycnometer)
Calibrate Volume Volume of Cal Std:	<p>Enter the volume of the calibration standard to be used in the calibration (located on the outside of the calibration standards case). Some pycnometers require and are shipped with multiple standards. In this instance, the value recorded on the case is the sum for all standards and is the one that should be entered at the prompt. Press ENTER.</p> <p>The range is 0.1 to 999.0000 cm³.</p>
Calibrate Volume [ENTER]	Press ENTER to begin the calibration or Alt + CLEAR to cancel. The volume offset is calibrated first (Cal1). When the first calibration is complete, the pycnometer beeps three times and the next prompt is displayed.
Insert Cal Std [ENTER] to start	<p>Place the calibration standard in the cup in the sample cell chamber and replace the chamber cap. Press ENTER to calibrate the temperature offset (Cal2). Calibration continues and operational status messages are continually displayed. After the operation is complete, the pycnometer returns to the <i>Reload</i> prompt.</p> <p>For best results, sample volume should be approximately equal to the volume of the calibration standard. Therefore, if calibrating the 10 cm³ pycnometer for use with smaller sample volumes, use only one standard. If using one standard, enter half of the value at the <i>Volume of cal std</i> prompt. Press Alt + CLEAR to cancel the operation.</p>

RESET PRESSURE CALIBRATION



Contact a Micromeritics service representative and schedule a proper pressure calibration since data accuracy may be compromised.

This option can be used when the pressure is suspected of not being reported correctly by the analyzer. For example: a zero, negative, or unreasonably high reading is being consistently reported. Resetting to nominal may restore normal pressure readings but a proper calibration should be performed.

Display Text	Description
Calibration Type? Reset Pressure Cal	Press CHOICE until the desired option is displayed, then press ENTER .
Reset Pressure cal? [Yes / No]	Resets the pressure calibration to nominal values. Temperature and volume calibrations are not affected. Nominal values may be sufficient. Schedule a proper pressure calibration as soon as possible, then press CHOICE . Select <i>Yes</i> to reset the calibration to nominal values. Press ENTER . Select <i>No</i> to contact your service representative to schedule a proper pressure calibration. Press ENTER .

REVIEW CALIBRATION

The *Review* function reviews the results of the last calibration operation.

The sample cell volume and the expansion cell volume are used for calculating the sample volume. The cell volume and expansion volume are updated automatically when the pycnometer is calibrated.

The prompts that display during a review of calibration data depend on the options specified in *Setup > Analysis Parameters* and *Report Options*.

1. Press **Alt + 5** to display the *Chamber Insert* prompt from which the insert can be selected (if used).
2. Press **ENTER** to display the volume of the calibration standard. This volume can be edited from this prompt.
3. Press **ENTER** to display the *Which Chamber* prompt.
4. Press **CHOICE** to select whether to view the results for the sample chamber or the expansion chamber.
5. Press **ENTER** to display a prompt showing the starting time and date.
6. Press **ENTER** to display a prompt showing the ending time and date.
7. Press **ENTER** to display the first of the prompts containing data. The *[n]* in this example represents the cycle number.

Unit[n]>	SN1234>	10 cm3
	X - X - X	
Cell [n] = (volume)		
Dev [n] = (deviation)		

8. Continue pressing **ENTER** to view all of the data. Press **CHOICE** to exclude data from report calculations. An asterisk will display indicating that it will be excluded.
9. Press **SAVE** to return to the *Reload* prompt
10. Press **Alt + 6** to print report results.

Display Text	Description
Chamber insert? (insert)	Displays the insert selected for the calibration or <i>None</i> if an insert was not used. If the selection is incorrect, press CHOICE until the correct one is shown, then press ENTER . <ul style="list-style-type: none"> • None, 0.1 cm³ (for 1 cm³ unit) • None, 3.5 cm³, 1.0 cm³ (for 10 cm³ unit) • None, 35 cm³, 10.0 cm³ (for 100 cm³ unit) • None, 650 cm³, 1300 cm³ (for 2000 cm³ pycnometer)
Volume of Cal Std: (volume)	Displays the volume of the calibration standard that was used for the calibration. Press ENTER .
Which Chamber? (chamber type)	Select to view calibration data for the sample cell chamber or the expansion chamber. Press CHOICE until the chamber is displayed, then press ENTER . The chamber type options are <i>Cell volume</i> and <i>Expansion volume</i> .
Start: (time) (date)	Displays the time and date the calibration began. Press ENTER . Time: HH:MM:SS Date: DD/MM/YY
End: (time) (date)	Displays the time and date the calibration completed. Press ENTER . Time: HH:MM:SS Date: DD/MM/YY
Cell[n] = (volume) Dv[n] = (deviations) or Exp[n] = (volume) Dv[n] = (deviations)	Displays the <i>Volume</i> , depending on the chamber type selected (<i>Cell volume</i> or <i>Expansion volume</i>). [n] represents the cycle number. Press CHOICE to exclude the displayed density (or volume) from the calculated average. An asterisk next to the density indicates it has been excluded. Press CHOICE again to remove the asterisk and have it included. Each time CHOICE is pressed to exclude or include the value. A new deviation is calculated and displayed. Press ENTER to view the values for the next cycle. Press SAVE to return to the <i>Reload</i> prompt. Press SAVE to automatically recalculate collected data and add all data reduction messages back into the queue.

TEMPERATURE

This operation typically is performed by a Micromeritics service representative.

Press **Alt + .**, then press **CHOICE** until *Temperature* is displayed.

Display Text	Description
Calibrate Temperature Temperature:	Enter the temperature obtained from a reference temperature sensor. Press ENTER to automatically return to the <i>Reload</i> prompt. Press ALT + CLEAR to cancel the operation.

ZERO THE PRESSURE TRANSDUCER & CHAMBER VOLUME

The pressure transducer zeroes automatically before each cycle in an analysis or calibration; therefore, it is not necessary to zero the unit for these operations. Typically, this function is not required unless manually performing analyses for an extended period of time.

Press **Alt + 0** to access the Zero function.

Display Text	Description
Zero Type? Pressure	Allows zeroing of the pressure transducer or the volume offset. Press CHOICE until the option is displayed, then press ENTER . If choosing <i>Pressure</i> , the next prompt is not displayed. Choices are <i>Pressure</i> and <i>Volume</i> . Ensure the sample chamber is empty if selecting <i>Volume</i> .
Zero Volume? Chamber insert? None <i>Does not display for Pressure</i>	Displays when <i>Volume</i> is selected. Select Yes at the <i>Request insert</i> prompt in <i>Report Options</i> . Press CHOICE until the appropriate insert is displayed, then press ENTER . <ul style="list-style-type: none"> • None, 0.1 cm³ (for 1 cm³ unit) • None, 3.5 cm³, 1.0 cm³ (for 10 cm³ unit) • None, 35 cm³, 10.0 cm³ (for 100 cm³ unit) • None, 650 cm³, 1300 cm³ (for 2000 cm³ pycnometer)
Zero Volume [ENTER] to start [ESCAPE] to cancel or Zero Pressure [ENTER] to start [ESCAPE] to cancel	Press ENTER to begin the zero operation or Alt + CLEAR to cancel the operation. If zeroing the <i>Volume</i> , the purges and cycles specified in the current analysis parameters are used to calculate the volume offset. After the operation is complete, the pycnometer returns to the <i>Reload</i> prompt.

LOAD CALIBRATION DATA FROM A USB STICK

Display Text	Description
Calibration Type? Load from USB Stick	Press CHOICE until the option is displayed. Press ENTER .
Insert USB stick and press [ENTER]	Insert the USB device into the USB connector on the rear panel of the unit. Press ENTER .
Local cal for SN:	Key in the serial number. Press ENTER .
Calibration for SN (nnnn) copied	Display the unit for which calibration information has been copied.
Remove USB stick	Remove the USB stick. The system automatically returns to the <i>Reload</i> prompt. This prompt appears immediately after the <i>Calibration for SN</i> prompt.

COPY CALIBRATION DATA TO A USB STICK

Display Text	Description
Calibration Type? Copy to USB Stick	Press CHOICE until the option is displayed. Press ENTER .
Insert USB stick and press [ENTER]	Insert the USB device into the USB connector on the rear panel of the unit. Wait a few seconds, then press ENTER .
Calibration for SN (nnnn) copied	Display the unit for which calibration information has been copied.
Remove USB stick	Remove the USB stick. The the <i>Reload</i> prompt displays.. This prompt appears immediately after the <i>Calibration for SN</i> prompt.

11 HARDWARE COMPONENTS AND ACCESSORY INSTALLATION

ADD ANALYSIS MODULE TO CONTROL MODULE

Additional analysis modules provide the ability to increase productivity and / or provide a means for analyzing different size samples concurrently. Multiple analysis modules can be connected to an integrated controller / analysis module.

If connecting to a temperature controlled unit, see ["Add Analysis Modules to a Temperature Controlled Module" on page F - 1.](#)

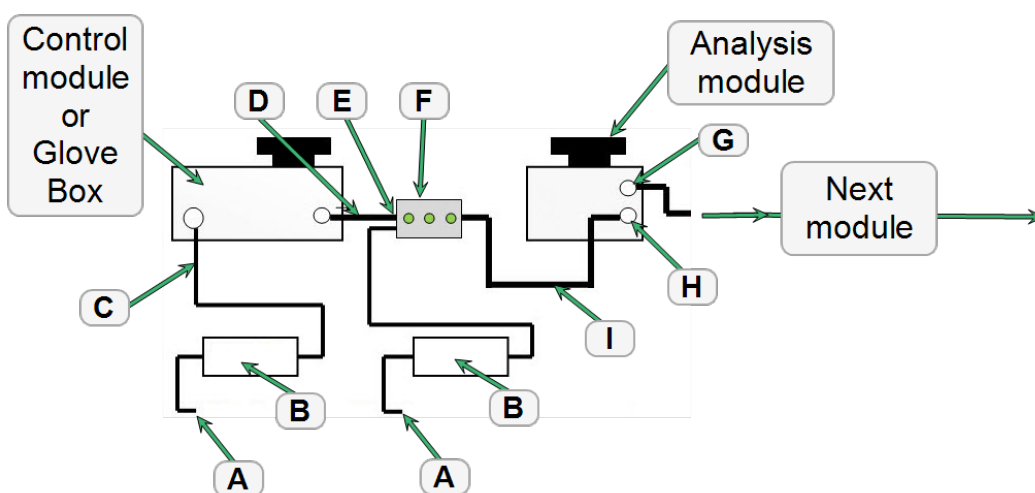

Diagram Components

Component	Description
A	Separate power cord for external power supply. Connect cable to wall outlet.
B	External power supply
C	Hardwired 8-pin mini-DIN power cable for external power supply.
D	8 pin mini DIN cable.
E	Power adapter DIN port.
F	Power adapter.
G	Module Connection - 8-pin mini-DIN OUT port to connect next analysis module.
H	Module Connection - 8-pin mini-DIN IN port to connect the control module or previously connected analysis module (not shown).
I	Hardwired power mini-DIN cable for power adapter.



If using the Windows version of the AccuPyc II, exit the application before powering off the analyzer.



If installing an external TEC module, it is suggested that the TEC system be installed first, to allow time for temperature to stabilize at the desired temperature, while the AccuPyc is being installed. The TEC module has a separate power cord and external power supply.

1. Power OFF the control module.
2. Connect one external power supply cable to the back of the new unit and another external power supply cable to each power adapter.
3. Connect a power cable to each external power supply.
4. Attach one end of the DIN cable (provided in the module accessories kit) to the connector labeled *Module Connection* on the back of the new unit.
5. Attach the other end of the DIN cable to the separate power adapter.
6. Attach the hardwired power adapter cable to the lower connector labeled *Module Connection* on the back of the analysis module.
7. Plug the external power supply cables into electrical wall outlets.
8. Power ON the control module. If running the application software, start the application.
9. Verify the unit is recognized:

- If running the application software, *Unit [n]* menus are added to the menu bar for each analysis module connected.

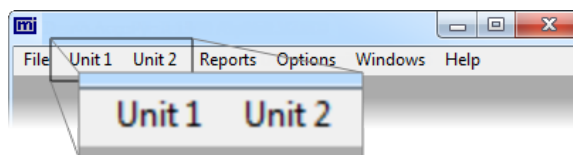

- If using the keypad for analysis, press **Alt + CHOICE + 2** to access the additional analysis module. *Unit [n]* appears in the upper left corner of the display.

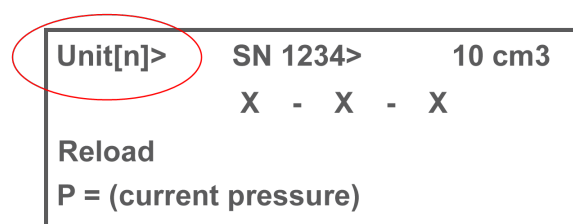

10. Calibrate the pycnometer. See ["Calibrate using the Keypad" on page 10 - 14](#) or ["Calibrate using the Software" on page 10 - 1](#).

CONFIGURE AN ANALYTICAL BALANCE

Options > Configure Balance



Used to connect and set up an RS-232 balance to the analyzer. See ["Connect an Analytical Balance" on page J - 6](#).

The analytical balance tested by Micromeritics is Scientec[®] model #ZSA120. See ["Parts and Accessories" on page 13 - 1](#).

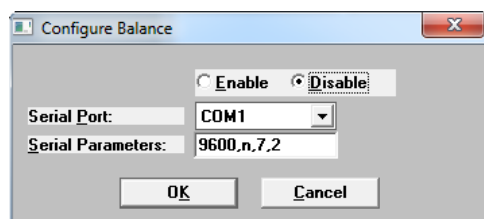

Configure Balance Fields and Buttons Table

Field or Button	Description
Enable / Disable	Select to enable or disable the attached balance.
Serial Parameter	Used to set the baud rate, parity, data bits, and stop bits. This field should not require modification from the default values.
Serial Port	Select which serial port is used to connect the balance to the analyzer.

PRINTER SETUP

Printers are connected to the AccuPyc II via a USB port. See ["Specifications" on page 1 - 10](#) for a list of supported printers. Using the keypad:

1. On the display, select *Setup > Report Options*.
2. Press **ENTER** until the *Printer?* prompt is displayed.

3. Press **CHOICE** until the appropriate printer driver is displayed.

12 MAINTENANCE AND TROUBLESHOOTING

What happened	Why	What to do
Power indicator did not illuminate when analyzer was power ON.	Power or DIN cables not fully inserted	Verify cable connections and connect any loose cable ends into proper outlets.
	No power at outlet.	Test the outlet. If there is no power, contact electrician.
	Plug prongs bent so that contact not made at outlet.	Unplug the power cable and re-plug into outlet. If indicator does not illuminate, have electrician adjust prongs or replace outlet or plug.
	Power cord damaged.	Have electrician check cord using test meter. Replace if defective.
	Loose internal connection, broken wire, or failure of internal power supply.	Contact a Micromeritics Service Representative for repair or replacement information.

What happened	Why	What to do
Specified pressure not reached or maintained.	Chamber cap not properly closed.	Close chamber cap by turning fully clockwise.
	Chamber cap contains dust or debris or the O-ring is not properly greased.	Using a lint free tissue, clean the chamber cap and the rim of the cell chamber. Lightly grease the chamber cap O-ring. See "Grease the Chamber Cap O-Ring" on page 12 - 4.
	The chamber cap O-ring is not properly seated.	Check the chamber cap. Ensure that the O-ring is properly seated and that it contains no scratches or cuts.
	The chamber cap O-ring is cut or scratched.	Replace the O-ring in the chamber cap. See "Replace the Chamber Cap O-Ring" on page 12 - 4.
	Gas leaks in the cell chamber or expansion chamber.	Check the pycnometer for leaks. See "Check for Leaks using the Keypad" on page 12 - 8 or "Check for Leaks using the Software" on page 12 - 6.
	The helium tank is low on gas, or empty.	Check tank. Minimum recommended pressure is 200 psig. See "Set Regulator Pressure" on page 12 - 14.
	The Shut-Off valve on the gas cylinder is closed.	Ensure that the valve is open.
	Pressure regulator defect or the pressure is set too low.	Check regulator to be sure it is set properly. See "Set Regulator Pressure" on page 12 - 14. Call a Micromeritics Service Representative, if necessary.
	The Zero offset (of pressure transducer) is too low.	Check offset by opening chamber cap. If pressure is negative (displayed on instrument schematic), run a new zero offset. See "Zero the Pressure Transducer & Chamber Volume" on page 10 - 19.
Dust filter on 2000 cm ³ unit is clogged or leaking to atmosphere.	Clean the dust filter. See "Clean the Dust Filter" on page 12 - 9.	

What happened	Why	What to do
Helium drained from tank.	Leaks in the gas line connection.	Pressurize the system. Close, then open the gas cylinder Shut-Off valve. If the needle on the pressure gauge falls abruptly, a leak in the gas line connections may be indicated. Check all gas line connections.
	Pycnometer was left in Manual mode with all the valves open or the fill valve open and chamber cap off.	Close all valves, then attach a new tank of helium.
Unit will not equilibrate, or results are not reproducible.	Sample outgassing.	Prior to analysis, remove moisture and contaminants from the sample. See "Preparing and Loading Sample" on page 6 - 1.
	Dust filter on 2000 cm ³ unit is clogged or leaking to atmosphere.	Clean the dust filter. See "Clean the Dust Filter" on page 12 - 9.
	Defective cap O-ring	Check cap O-ring for defects. Regrease or replace the O-ring, if necessary.
	Debris on valves	With manual mode enabled and with the cap installed, open all valves. With helium flowing through the pycnometer, open and close the expansion valve repeatedly for approximately one minute. This will remove sample contamination, which may cause a leak, from the valve seat. Repeat the process for the vent valve with the inlet and expansion valves open.

CHAMBER CAP O-RING

The cell chamber cap contains an O-ring that requires routine maintenance. The chamber cap O-ring should be greased at the beginning of each period of use.

Fine fibers and particles between the O-ring and its sealing surfaces can cause leaks, as can scratches or cuts in the O-ring or in the metal surfaces.

GREASE THE CHAMBER CAP O-RING

1. Turn the chamber cap counter-clockwise and lift it from the chamber.
2. Place the chamber cap on a clean surface with the O-ring side exposed.
3. Use a small drop of Dow Corning high vacuum grease (or equivalent).
4. Distribute the grease evenly and completely around the O-ring groove.



5. Replace the chamber cap.
6. If recalibrating the pycnometer, allow the pycnometer to warm up for 30 minutes before calibrating.

REPLACE THE CHAMBER CAP O-RING

1. Use a pointed tool and carefully remove the O-ring from its groove in the cap. A small niche is provided at the groove for placement of the tool.





Do not to scratch the metal surface of the chamber cap. Scratches could result in an imperfect seal.

2. Clean the groove in the chamber cap using a small brush or lint-free tissue moistened with isopropyl alcohol.
3. Allow the chamber cap to dry thoroughly.
4. Use a small drop of Dow Corning high vacuum grease (or equivalent).
5. Grasp the O-ring with the two greased fingers. Distribute the grease evenly and completely around the O-ring.



Apply the grease sparingly. Too much grease may alter cell volume while too little grease results in an imperfect seal and leaks.

6. Place the O-ring back into the groove on the cap and, with the greased index finger, gently press it back into position.
7. Ensure the O-ring groove is properly greased. See ["*Grease the Chamber Cap O-Ring*" on the previous page.](#)
8. Replace the chamber cap.

CHECK THE CELL AND EXPANSION CHAMBERS FOR LEAKS

This procedure should be performed in a temperature-stable environment after the pycnometer has been allowed to warm for at least two hours. Before performing this procedure, check the chamber cap to ensure that it is not the source of leaks. It should be free from particles, the O-ring should be properly seated, and should not contain excessive grease.

CHECK FOR LEAKS USING THE SOFTWARE



Before performing this procedure, check the chamber cap to ensure that it is not the source of leaks. It should be free from particles, the O-ring should be properly seated, and it should not contain excessive grease.

1. Allow the pycnometer to equilibrate thermally in a room having a stable temperature.
2. Go to **Unit [n] > Enable Manual Control**. Ensure a checkmark displays to the left of the menu item. The instrument schematic should display. If not, go to **Unit [n] > Show Instrument Schematic**.
3. If the system has been open, manually purge the system before proceeding:
 - a. On the schematic, open the *Expansion* valve and close the *Vent* valve.
 - b. Open the *Fill* valve and fill the sample chamber (1-, 10-, 100 cm³) or expansion chamber (1- and 2000 cm³) to the correct pressure. Pressure is displayed to the left of the chamber on the schematic.
 - c. Close the *Fill* valve and open the *Vent* valve.
 - d. Repeat steps (a) through (c) two or three times.
 - e. Close the *Expansion* valve.
4. Open the *Fill* valve.
5. Fill the first chamber to 19.5 psig (134.4 kPag).
6. Close the *Fill* valve.
7. Observe the pressure display. After an equilibration period (about 20 to 30 seconds), the pressure should not decrease more than 0.007 psig (0.048 kPag) or increase more than 0.02 psig (0.14 kPag) in a two minute span.
 - If the pressure does not decrease more than 0.007 psig (0.048 kPag) or increase more than 0.02 psig (0.14 kPag) in a two minute span, proceed to step 8.
 - If the pressure decreases more than 0.007 psig (0.048 kPag) or increases more than 0.02 psig (0.14 kPag) in a two minute span, temperature instability or a leak may be indicated. Vent the system, then repeat steps 4 through 7 several times to verify that a leak is indicated. If a leak is indicated, call a Micromeritics Service Representative.
8. Close the *Vent* valve, then open the *Expansion* valve and the *Fill* valve.

9. Fill the chambers to 19.5 psig (134.4 kPag).
10. Close the *Fill* valve.
11. Observe the pressure display. After an equilibration period (about 20 to 30 seconds), the pressure should not decrease more than 0.007 psig (0.048 kPag) or increase more than 0.02 psig (0.14 kPag) in a two minute span.

If the pressure decreases more than 0.007 psig (0.048 kPag) or increases more than 0.02 psig (0.14 kPag) in a two minute span, temperature instability or a leak may be indicated. Vent the system, then repeat steps 8 through 11 several times to verify that a leak is indicated. If a leak is indicated, call a Micromeritics Service Representative.

CHECK FOR LEAKS USING THE KEYPAD



Before performing this procedure, check the chamber cap to ensure that it is not the source of leaks. It should be free from particles, the O-ring should be properly seated, and it should not contain excessive grease.

Check the cell and expansion chambers for leaks.

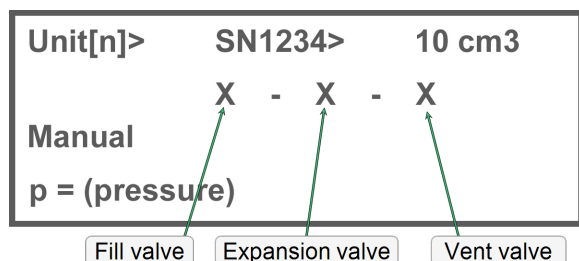

1. Allow the pycnometer to equilibrate thermally in a room with a stable temperature.
2. Press **Alt + 1** to enter Manual mode.
3. If the system was previously open, manually purge the system before proceeding:
 - a. Press **8** to open the *Expansion* valve and **9** to close the *Vent* valve; **X - O - X**.
 - b. Press **7** to open the *Fill* valve. Once the sample chamber fills to the appropriate pressure, press **7** to close the *Fill* valve.
 - c. Press **9** to open the *Vent* valve; **X - O - O**.
 - d. Repeat this procedure two or three times.
 - e. Press **8** to close the *Expansion* valve; **X - X - O**.
4. Press **7** to open the *Fill* valve; **O - X - O**.
5. Fill the sample chamber to 19.5 psig.
6. Press **7** to close the *Fill* valve; **X - X - O**.
7. Observe the pressure display. After an equilibration period (about 20 to 30 seconds), the pressure should not decrease more than 0.007 psig (0.048 kPag) or increase more than 0.02 psig (0.14 kPag) in a two minute span.
 - If the pressure does not decrease more than 0.007 psig (0.048 kPag) or increase more than 0.02 psig (0.14 kPag) in a two minute span, proceed to step 8.
 - If the pressure decreases more than 0.007 psig (0.048 kPag) or increases more than 0.02 psig (0.14 kPag) in a two minute span, temperature instability or a leak may be indicated. Vent the system, then repeat steps 4 through 7 several times to verify that a leak is indicated. If a leak is indicated, call a Micromeritics Service Representative.
8. Press **9** to close the *Vent* valve, **8** to open the *Expansion* valve, and **7** to open the *Fill* valve; **O - O - X**.

9. Fill the chambers to 19.5 psig.
10. Press **7** to close the *Fill* valve; **X - O - X**.
11. Observe the pressure display. After an equilibration period (about 20 to 30 seconds), the pressure should not decrease more than 0.007 psig (0.048 kPag) or increase more than 0.02 psig (0.14 kPag) in a two minute span.

If the pressure decreases more than 0.007 psig (0.048 kPag) or increases more than 0.02 psig (0.14 kPag) in a two minute span, temperature instability or a leak may be indicated. Vent the system, then repeat steps 8 through 11 several times to verify that a leak is indicated. If a leak is indicated, call a Micromeritics Service Representative.

CLEAN THE DUST FILTER



Applicable to 2000 cm³ units only.

Dust from the sample may be carried into the instrument plumbing. A dust filter protects the valves, minimizing valve leaks.

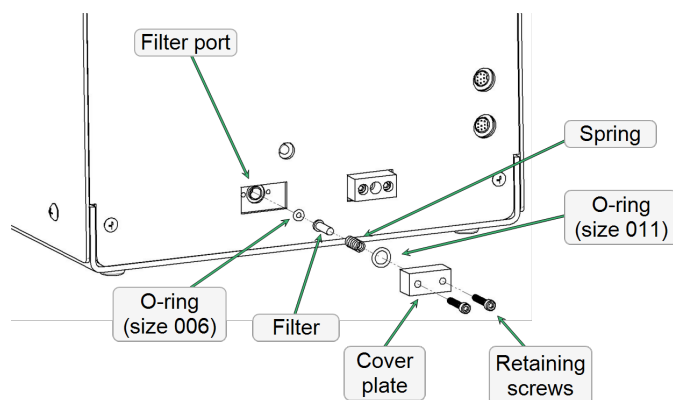

1. Press **Alt+1** to enter Manual mode.
2. Close the *Fill* valve. Open the *Expansion* and *Vent* valves to ensure that the system is not under pressure.
3. At the lower rear of the instrument, remove the two screws which hold the dust filter cover and remove the cover plate.
4. Remove the spring and the filter. Remove the small O-ring inside the filter port.
5. Clean all parts with alcohol. The filter may require sonication to dislodge dust. It should be replaced if it becomes severely clogged.
6. Inspect the O-rings before re-assembly. A very thin coating of vacuum grease may be used.

7. Re-assemble.
8. Check for leaks:
 - a. Fill the system with gas.
 - b. Open *Expansion* valve.
 - c. Check for leaks by applying a leak detecting liquid around the dust filter cover.

CLEAN THE PYCNOMETER

The exterior casing of the pycnometer may be cleaned using a clean cloth, dampened with isopropyl alcohol (IPA), a mild detergent solution, or a 3% hydrogen peroxide solution.



Do not immerse the pycnometer or the power cord in any liquids. Doing so could result in electrical shock to personnel or damage to the unit.



Do not allow liquid to penetrate the casing of the pycnometer. Doing so could result in damage to the unit.

RECOVER FROM A POWER FAILURE

Setup parameters and collected data are recorded by the pycnometer in case of a power failure. These settings will be available when power is restored. If an automatic operation was in progress when the power failure occurred, it will be canceled when the pycnometer restarts.



Even though the pycnometer saves data during a power failure, any operation should be restarted to ensure complete results.

RESET THE PYCNOMETER

There are two ways to reset the Pycnometer.

- Hold the . key on the keypad during power ON. This erases data and setup parameters except for printer and network settings.
- Hold 5 on keypad during power ON. This resets setup parameters, as well as printers and network settings.

GUIDELINES FOR CONNECTING GASES

- Place gas cylinders close to the analyzer. Using gas line extenders on gas cylinders located in remote areas may degrade gas quality and reduce pressure. Gas lines are typically five to six feet long. Place the bottles close enough to allow for proper connection at the analyzer inlet.
- Use a retaining strap (or other appropriate tether) to secure the gas cylinder.
- Always use the gas lines provided with the analyzer. It is very important that proper gas lines are used with the analyzer.
 - **Do not use** polymer tubing for the gas line.
 - **Do not use** flexible gas lines. Some flexible lines may appear to be appropriate, such as those with a herringbone covering, but the line may be coated internally with a polymer.
- Long gas lines, such as those used with gas cylinders placed in remote areas, must be evacuated for an extended period of time to remove ambient gases. When possible, avoid placing gas cylinders in remote locations. It is always better to have gas cylinders located near the analyzer.
- Carefully route the gas lines from the cylinder to the analyzer avoiding overlapping or entangling gas lines. This will help avoid confusion in the event maintenance is required.
- Label the gas line at the analyzer inlet for proper identification and maintenance.
- Replace gas cylinders before gas is depleted. It is best to replace a gas cylinder when the pressure reads approximately 200 psi on the high-pressure gauge. Contaminants absorbed to the walls of the cylinder will desorb as the pressure decreases.
- Ensure the gas cylinder is closed before connecting to the analyzer.

REPLACE A GAS CYLINDER



These instructions apply to working with inert gases only. When working with hazardous gases, follow the safety procedures established by your lab.



A power failure can result in dangerous pressures in the sample chamber. When using toxic or flammable gases, additional venting of the cabinet may be required.

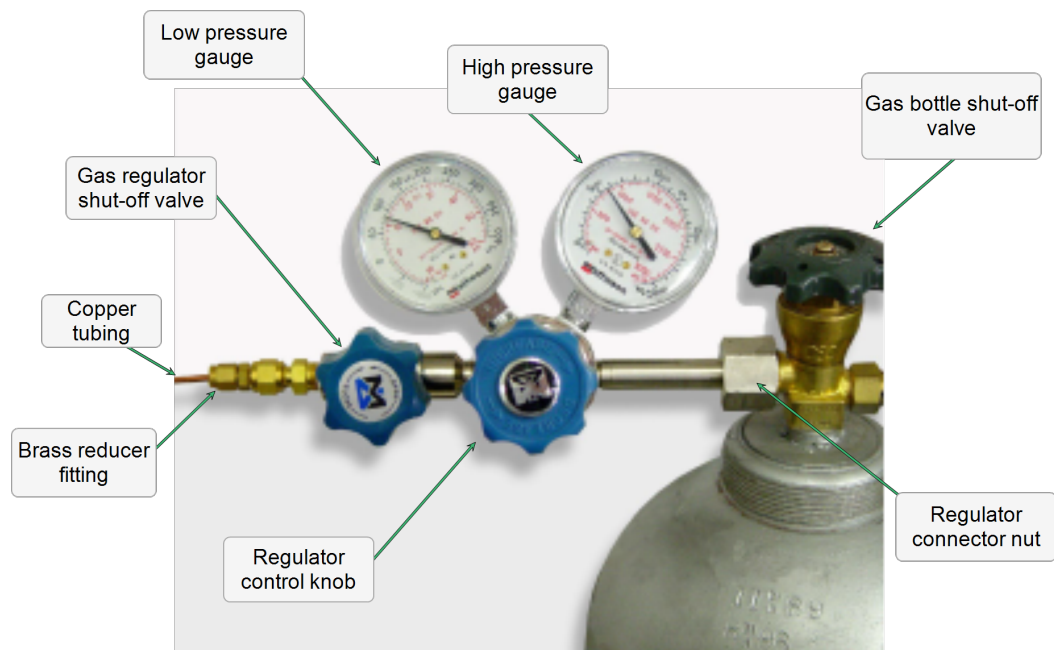

Disconnect the Depleted Gas Cylinder

1. Close the gas cylinder shut-off valve by turning the valve clockwise.
2. Disconnect the gas line from the regulator and allow the regulator line to purge. The gas will begin to vent. It is not necessary to disconnect the gas line from the analyzer inlet.
3. Open the gas regulator shut-off valve by turning the valve counter-clockwise. The gas will continue to vent.
4. Turn the regulator control knob clockwise to open and vent any remaining gas. Both gauges should read at or near zero. If not, open the gas regulator shut-off valve to release gas. It is not necessary to disconnect the gas line from the regulator or the analyzer.

5. Close the regulator control knob.
6. Use an appropriate wrench to loosen the nut at the regulator / gas cylinder connection then remove the regulator from the bottle.
7. Replace the protective cap on the depleted bottle. Disconnect the retaining strap and move the bottle to an appropriate location.

Connect A Gas Cylinder

Move the replacement bottle close to the analyzer and tether it into place. It is not necessary to disconnect the gas line from the regulator or the analyzer.

1. Use an appropriate cylinder wrench to remove the protective cap from the replacement gas cylinder. Place the protective cap in a secure location. It will be needed to recap the gas cylinder when it is depleted and replaced.
2. Attach the gas regulator to the gas cylinder connector. Hand-tighten the nut, then use an appropriate wrench to tighten an additional 3/4 turn.



Over-tightening the fitting may cause a leak.

3. Check for leaks at the high-pressure side of the regulator and in the connector.
 - a. Turn the regulator control knob fully counter-clockwise.
 - b. Slowly open the gas cylinder shut-off valve, then quickly close it.
 - c. Observe the pressure on the high-pressure gauge for approximately one minute:
 - If the pressure is stable, proceed with the next step.
 - If the pressure decreases, tighten the regulator connector nut until it becomes stable. If the pressure does not remain stable, remove the regulator and clean all contacts at the regulator connection, then reinstall the regulator.
4. Purge the lines and set the regulator pressure.
 - a. If the gas line is not connected to the regulator and the instrument connect it now.
 - b. Fully open the gas bottle shut-off valve and the gas regulator shut-off valve.
 - c. Under manual control, open the fill, expand, and vent valves.
 - d. Adjust the regulator pressure control knob until the *Purge fill* or *Cycle fill* pressure, whichever is higher, is shown on the regulator display.
 - e. Allow gas to flow for 30 seconds.
 - f. Close the fill, expand, and vent valves.
 - g. Turn the regulator control knob clockwise to increase pressure by 2 psi (15 kPa).

SET REGULATOR PRESSURE

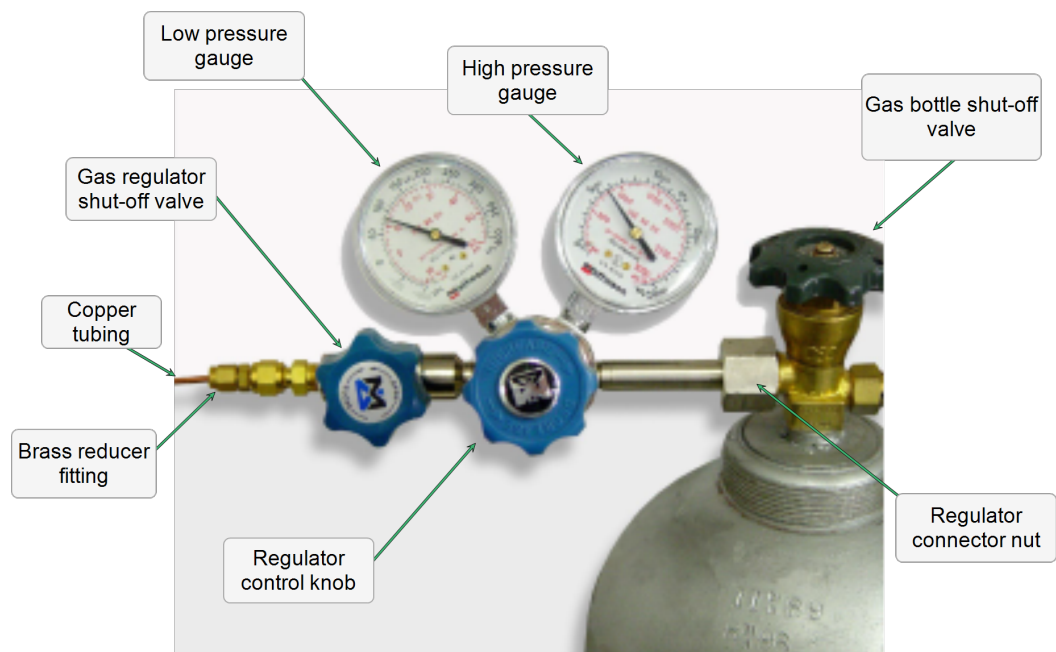

SET REGULATOR PRESSURE WITH THE SOFTWARE



Ensure the tank pressure for the gas regulator is at least 200 psig. Pressures less than 200 psig indicate the tank is low on gas. Analyses are terminated automatically if gas is depleted.

The *Purge fill* and *Cycle fill* pressures are specified in *Analysis Conditions*. Set the regulator pressure at the higher of the two, plus 2.0 psig. For example; if the *Purge fill* pressure is set to 19.500 psig (134.445 kPag) and the *Cycle fill* pressure as 19.000 psig (131.000 kPag), set the regulator pressure at 21.500 psig (148.237 kPag).

1. Verify that the tank pressure for the gas regulator is at least 200 psig (1379 kPag).
2. Go to **Unit [n] > Enable Manual Control**. Ensure a checkmark displays to the left of the menu item. The instrument schematic should display. If not, go to **Unit [n] > Show Instrument Schematic**.
3. On the schematic, right click the *Expansion* and *Vent* valves and select *Open* for both. Then open the *Fill* valve.
4. Adjust the regulator pressure control knob until the *Purge fill* or *Cycle fill* pressure, whichever is higher, is shown on the regulator display.

5. On the schematic, close the *Fill* valve, then increase the regulator pressure by 2.0 psig (13.8 kPag).
6. Allow the pressure in the pycnometer to drop below 2.0 psig, then close the *Expansion* and *Vent* valves.

SET REGULATOR PRESSURE WITH THE KEYPAD



Ensure the tank pressure for the gas regulator is at least 200 psig. Pressures less than 200 psig indicate the tank is low on gas. Analyses are terminated automatically if gas is depleted.

The *Purge fill* pressure and *cycle fill* pressure are specified using *Setup > Analysis Parameters*. Set the regulator pressure at the higher of the two (plus 2.0 psig). For example; if the *purge fill* pressure is specified as 19.500 psig and the *cycle fill* pressure as 19.000 psig, then set the regulator pressure at 21.500 psig.

1. Press **Alt + 1** to enter Manual mode.
2. Press **8** (*EXPAND*) and **9** (*VENT*) to open the expansion and vent valves; the display will show: **X - O - O**
3. Press **7** (*FILL*) to open the *fill* valve; the display will show: **O - O - O**
4. Adjust the regulator pressure control knob until the *Purge fill* or *Cycle fill* pressure, whichever is higher, is shown on the regulator display.
5. Press **7** to close the *Fill* valve, then increase the regulator valve by 2.0 psig. The display will show: **X - O - O**.
6. Allow the pressure in the pycnometer to drop below 2.0 psig, then press **8** and **9** to close the *Expansion* and *Vent* valves. The display will show: **X - X - X**
7. Press **SAVE** to return to the *Reload* prompt.

Blank Page

13 PARTS AND ACCESSORIES

Order system components and accessories using one of the following methods:

- Call our Customer Service Department at 1-770-662-3636
- Email orders to Orders@Micromeritics.com
- Contact your local sales representative

Part Number	Item and Description
Analyzer Equipment	
134-00000-00	AccuPyc II, 10 cm ³ capacity
134-00001-00	AccuPyc II, 1 cm ³ capacity
134-00002-00	AccuPyc II, 100 cm ³ capacity
134-00005-00	Control Module, no sample compartment
134-00010-00	AccuPyc II, flowing temperature control, 10 cm ³ capacity
134-00020-00	AccuPyc II, flowing temperature control, 100 cm ³ capacity
134-00030-00	AccuPyc II Glove Box, 10 cm ³ capacity
134-00031-00	AccuPyc II Glove Box, 1 cm ³ capacity
134-00032-00	AccuPyc II Glove Box, 100 cm ³ capacity
134-00033-00	AccuPyc II Glove Box, 350 cm ³ capacity
134-00034-00	AccuPyc II Glove Box, 2000 cm ³ capacity
134-00035-00	AccuPyc II TEC, 10 cm ³ , Glove Box
134-00036-00	AccuPyc II TEC, 100 cm ³ , Glove Box
134-00040-00	Analysis module, 10 cm ³ capacity
134-00041-00	Analysis module, 1 cm ³ capacity
134-00042-00	Analysis module, 100 cm ³ capacity
134-00043-00	Analysis module, 350 cm ³ capacity
134-00044-00	Analysis module, flowing temperature control, 10 cm ³ capacity
134-00045-00	Analysis module, flowing temperature control, 100 cm ³ capacity
134-00046-00	Analysis module, 2000 cm ³ capacity
134-00047-00	Analysis module 1340 TEC, 10 cm ³
134-00048-00	Analysis module 1340 TEC, 100 cm ³
134-00050-00	AccuPyc II TEC, 10 cm ³
134-00051-00	AccuPyc II TEC, 100 cm ³
Cables	
003-60623-00	Cable, 2 ft; for connecting analysis modules
003-60623-01	Cable, 25 ft; for connecting Control module to Glove box unit

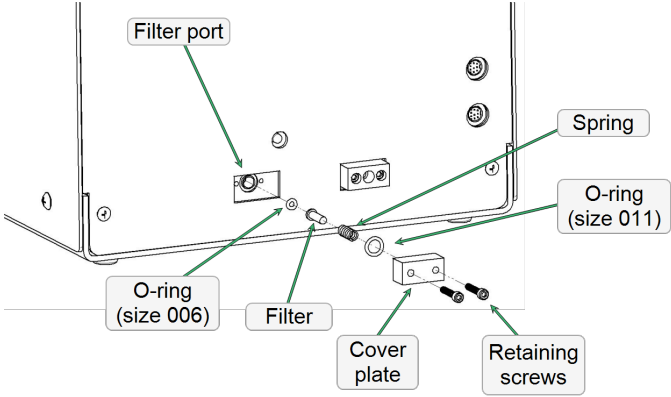
Part Number	Item and Description
003-63801-00	Ethernet cable, cross-over
003-63821-00	Null Modem Cable, for connecting Analytical Balance to Controller/Data Management Module
Calibration Kit	
133-34900-00	Calibration Standard Kit, 10 cm ³ ; contains two calibration standard and one sample cup
134-34901-00	Calibration Standard Kit, 2000 cm ³ ; contains one calibration standard and one 2000 cm ³ sample cup
133-34902-00	Calibration Standard Kit, 100 cm ³ ; contains one calibration standard and one 100 cm ³ sample cup
133-34903-00	Calibration Standard Kit, 350 cm ³ ; contains 3 calibration standard and one sample cup
Chamber Cap O-rings	
004-25032-00	Chamber cap O-ring, 2000 cm ³
004-25575-00	Chamber cap O-ring, 10 cm ³
004-25577-00	Chamber cap O-ring, 100 cm ³
004-25637-00	Chamber cap O-ring, 1 cm ³
004-25689-00	Chamber cap O-ring, 350 cm ³
Dust Filter Components (for 2000 cm³ units only)	
	
004-25006-00	O-ring, -006 70 DURO BUNA-N
004-25011-00	O-ring, -011 70 DURO BUNA-N
004-25312-00	Compression spring
004-27082-00	Filter, Line, 10 Micron
Equipment (Optional)	
011-00000-00	Scientec Analytical Balance, model ZSA120
133-33604-00	MultiVolume Kit for 100 cm ³ pycnometer; includes 10 cm ³ and 35 cm ³ inserts and appropriate sample cups

Part Number	Item and Description
133-33605-00	MultiVolume Kit for 10 cm ³ pycnometer; includes 1 cm ³ and 3.5 cm ³ inserts and appropriate sample cups
134-33605-00	MultiVolume Kit for 2000 cm ³ pycnometer; includes 650 cm ³ and 1300 cm ³ , cups, inserts, and reference standards
134-33006-00	MultiVolume Kit for 1 cm ³ pycnometer; includes 0.1 cm ³ insert / sample cup combination
Filtered Cup Assemblies (Optional)	
133-25862-00	Filtered cup assembly, 10 cm ³ ; used to constrain powdered samples
133-25863-00	Filtered cup assembly, 100 cm ³ ; used to constrain powdered samples
Filtered Cup Assembly Components (for 100 cm³ units only)	
004-25299-00	O-ring, size -024 70 DURO BUNA-N
004-27055-00	Paper filter (100 pack)
133-25845-01	Modified 100 cc sample cup
133-25901-00	100 cc sample cup filter cap
133-25902-00	Spring clip for 100 cc sample cup cap
Gas Accessories	
004-25549-00	Reducer, 1/8 in. tube × 1/4 in. tube
004-62230-58	Gas regulator, 30 psig, CGA 580
134-33020-00	Multigas Manifold; to connect multiple gases to the analysis unit
290-25846-00	Gas inlet line assembly
Keypad Template	
134-42701-01	French template
134-42701-02	German template
134-42701-03	Spanish template
134-42701-04	Italian template

Part Number	Item and Description
Operating Supplies	
0089-16045-00	High Vacuum grease, Dow Corning
Power Accessories	
003-40054-00	AC/DC power supply, external
003-40058-00	AC/DC external power supply, for TEC module on TEC instruments
003-60101-00	Power cord, US, Canada, Japan
003-60101-05	Power cord, Schuko, for European countries
134-34007-00	Power Adapter
Sample Cups	
134-25600-00	Sample cup, disposable, 2.5 cm ³ capacity (qty. 50)
133-25805-00	Sample cup, 10 cm ³ capacity
133-25805-02	Sample cup, 10 cm ³ capacity, stainless steel
133-25845-00	Sample cup, 100 cm ³ capacity
133-25845-02	Sample cup, 350 cm ³ capacity
133-25855-02	Sample cup, 1 cm ³ capacity
134-25874-00	Sample cup, 2000 cm ³ capacity (used with CorePyc)
134-25875-00	Sample cup, 1300 cm ³ capacity (used with CorePyc MultiVolume kit)
134-25876-00	Sample cup, 650 cm ³ capacity (used with CorePyc MultiVolume kit)
134-33007-00	Disposable Sample Cup Kit, for AccuPyc II (10 cm ³) includes chamber insert for 2.5 cm ³ (nominal) disposable aluminum cups, calibration sphere, plus 50 disposable cups.
135-25804-00	Sample cup, 35 cc capacity (used with 100 cc MultiVolume kit)
135-25805-00	Sample cup, 3.5 cc capacity (used with 10 cc MultiVolume kit)
Software and Manuals	
134-20802-00	AccuPyc II Software for Windows
134-20804-00	AccuPyc II Software for Windows (with FoamPyc)
134-20808-00	AccuPyc II Software for Windows (Asphalt)
134-33005-00	Windows Upgrade for FoamPyc; includes software and operator manual
134-42800-00	AccuPyc II Operator Manual (includes keypad and software versions, binder and dividers)

A ERROR MESSAGES

2201 | Cannot execute report subsystem.

Cause: Start Report failed to execute the report subsystem (which is a separate process).

Action: Restart the computer. If the problem persists, reinstall the application (this will not affect any of your sample files). Contact a Micromeritics service representative if this error message continues.

2204 | Communication attempt with [n] failed [n]. Please check application directory for file.

Cause: A file necessary for reporting is missing.

Action: Re-install the software.

2401 | FATAL ERROR.

Cause: An internal processing and / or hardware error has occurred during communication with the analyzer.

Action: Contact your Micromeritics service representative.

2430 | Error accessing file [n], error code = [n].

Cause A: Media may be damaged.

Action A: Clean the media drive. If this does not eliminate the problem, attempt operation using a backup copy of the file.

Cause B: Hard disk may be damaged.

Cause B: Contact your Micromeritics service representative.

Cause C: A software error occurred when the file was accessed.

Cause C: Contact your Micromeritics service representative.

Cause D: The file name specified contains one or more invalid characters.

Cause D: Enter a valid file name. Do not use characters such as * or ?. Refer to the operating system manual.

2431 | Error writing file [n], error code = [n].

Cause : Insufficient hard disk to perform the operation.

Action : Copy files not used regularly from the hard disk external media. Delete them from the hard disk, and then try the operation again.

2432 | Invalid response from MMI 'FILE_READ' request.

Cause: An internal processing and/or hardware error has occurred.

Action: Contact a Micromeritics service representative if this error message continues.

2433 | New entries have been found in this directory. Refresh the directory information?

Cause: Several analyzer files (sample information, analysis conditions, adsorptive properties, or report options) have been added to this directory by some function other than the analyzer program.

Action: Click **Yes** to update the directory information with data from each new file. This operation may take a minute.

Click **No** to locate the file manually. This option may be feasible if a large number of files have been copied into the directory and the file name is known.

2434 | File [n] — Subset [n] wrote wrong [n] of data, expected [n] bytes.

Cause: An internal processing and/or hardware error has occurred.

Action: Contact your Micromeritics service representative.

2436 | Path specification [n] is invalid.

Cause: An invalid path name and / or extension was entered.

Action: Type a valid path name (including the proper extension), then press **Enter**.

2437 | File name [n] does not exist.

Cause: The entered file specification does not exist.

Action: Enter an existing file specification, or select a file name from the list box.

2439 | Could not register file.

Cause: An unexpected error occurred when trying to access a data file.

Action: Contact your Micromeritics service representative.

2440 | Subset not found.

Cause: An unexpected error occurred when trying to access a data file.

Action: Contact your Micromeritics service representative.

2441 | Seek within file failed.

Cause: An unexpected error occurred when trying to access a data file.

Action: Contact your Micromeritics service representative.

2442 | Bad header in subset file.

Cause: An unexpected error occurred when trying to access a data file.

Action: Contact your Micromeritics service representative.

2443 | Subset owner denied access.

Cause: An unexpected error occurred when trying to access a data file.

Action: Contact your Micromeritics service representative.

2444 | Not a valid file format.

Cause: An unexpected error occurred when trying to access a data file.

Action: Contact your Micromeritics service representative.

2445 | Subset wrote the wrong amount of data.

Cause: An unexpected error occurred when trying to access a data file.

Action: Contact your Micromeritics service representative.

2446 | Error reading data.

Cause: An unexpected error occurred when trying to access a data file.

Action: Contact your Micromeritics service representative.

2447 | Error writing data.

Cause: An unexpected error occurred when you tried to access a data file.

Action: Contact your Micromeritics service representative.

2448 | Basic Mode default parameter file directory [n] is invalid. Resetting to the installation directory.

Cause: A working directory specified in the .INI file is invalid, has been moved, or has been deleted.

Action: The installation directory will be substituted. The next time a file is opened, use the directories list to move to the correct directory.

2448 | Default Adsorptive Properties directory [n] is invalid. Resetting to the installation directory.

Cause: A working directory specified in the .INI file is invalid, has been moved, or has been deleted.

Action: The installation directory will be substituted. The next time a file is opened, use the directories list to move to the correct directory.

2448 | Default parameter file directory [n] is invalid. Resetting to the installation directory.

Cause: A working directory specified in the .INI file is invalid, has been moved, or has been deleted.

Action: The installation directory will be substituted. The next time a file is opened, use the directories list to move to the correct directory.

2448 | Default report options directory [n] is invalid. Resetting to the installation directory.

Cause: A working directory specified in the .INI file is invalid, has been moved, or has been deleted.

Action: The installation directory will be substituted. The next time a file is opened, use the directories list to move to the correct directory.

2448 | Default sample file directory [n] is invalid. Resetting to the installation directory.

Cause: A working directory specified in the .INI file is invalid, has been moved, or has been deleted.

Action: The installation directory will be substituted. The next time a file is opened, use the directories list to move to the correct directory.

2448 | Default script test file directory [n] is invalid. Resetting to the installation directory.

Cause: A working directory specified in the .INI file is invalid, has been moved, or has been deleted.

Action: The installation directory will be substituted. The next time a file is opened, use the directories list to move to the correct directory.

2448 | The reference file directory [n] cannot be used. Resetting to the installation directory.

Cause: A working directory specified in the .INI file is invalid, has been moved, or has been deleted.

Action: The installation directory will be substituted. The next time a file is opened, use the directories list to move to the correct directory.

2448 | The z-table file directory [n] cannot be used. Resetting to the installation directory.

Cause: A working directory specified in the .INI file is invalid, has been moved, or has been deleted.

Action: The installation directory will be substituted. The next time a file is opened, use the directories list to move to the correct directory.

2449 | This field does not contain a valid file specification.

Cause: An invalid file name was entered.

Action: See the description of file naming conventions in a Windows manual, then re-enter the name.

2450 | Sample Defaults may not be edited while this operation is in progress. Do you wish to save and close the Sample Defaults edit session?

Cause: An automatic analysis (an analysis in which sample files are created using the defaults) was processing while editing the defaults.

Action: Finish the edit session of the defaults, close the window, then restart the automatic analysis.

2452 | Attempt to write MICATTR.DIR in read only mode. [n]

Cause: The *Read-Only* attribute is turned on in the application's MICATTR.DIR file (this file exists in each folder containing sample or parameter files).

Action: Use Windows Explorer to access the folder containing the MICATTR.DIR file, then disable the *Read-Only* option.

2453 | Attempt to append MICATTR.DIR in read only mode. [file name]

Cause: The *Read-Only* attribute is turned on in the application's MICATTR.DIR file (this file exists in each folder containing sample or parameter files).

Action: Use Windows Explorer to access the folder containing the MICATTR.DIR file, then disable the *Read-Only* option.

2454 | Too many selections for a print-to-file operation. Only the first (number) selections will be processed. Please reselect the remainder.

Cause: Too many files were selected for this operation.

Action: Select only the number of files specified in the message.

2455 | Too many selections for an export-to-file operation. Only the first (number) selections will be processed. Please reselect the remainder.

Cause: Too many files were selected for this operation.

Action: Select only the number of files specified in the message.

2456 | Insufficient file handles available. Application cannot continue.

Cause: More than 50 files are open at the same time.

Action: Refer to an operating system manual then set the limit for open files to 50 or greater.

2457 | Results cannot be displayed. More than [n] windows are currently displaying or printing results.

Cause: Too many windows are open in the application.

Action: Close some of the open windows.

2458 | An instrument is performing a critical operation. Wait a few moments before exiting the application.

Cause: An attempt was made to exit the application while the instrument was performing a critical operation. This operation must be completed before the application can be exited.

Action: Wait a short time and attempt to exit the application again.

2459 | An instrument is busy. A delay in restarting this application could result in loss of new data. Continue with program Exit?

Cause: An attempt was made to exit the application while an analysis was in progress. While this is possible, the data collected when the application is inactive will not

be permanently recorded until the application is re-started. A power failure to the instrument could cause some data to be lost.

Action: If not concerned with the potential for loss of data should a power failure occur, click **Yes** to continue; otherwise, click **No**.

2460 | Fatal Communications error on [n].

Cause: There was a fatal error in communication between the application and the software in the instrument. All displays for that instrument will be closed.

Action: Ensure that the analyzer is connected to the computer on the communications port configured in the *Setup* program. Stop and restart the analyzer software. Contact your Micromeritics service representative.

2461 | No instruments are in operation. This application will unconditionally terminate.

Cause: At least one instrument must be active for the application to operate. The initialization of all of the instruments configured with the Setup program has failed. The application stops.

Action A: Usually this message is preceded by another message giving the reason for the instrument's failure to initialize. Refer to the instructions for that message.

Action B: Ensure that the instrument is attached to the computer on the communications port configured with the *Setup* program. Verify that the instrument's power switch is in the ON position and that the light on the front panel is illuminated. If the application continues to fail in its attempts to initialize the instrument, contact your Micromeritics service representative.

2477 | [n] did not properly initialize.

Cause: The software was unable to initialize this instrument. This is usually caused by one of the conditions listed in the previous error messages.

Action A: Run the *Setup* program and ensure that a valid port is specified; if not, specify a valid one when prompted.

Action B: Reinstall the software, then restart application.

Action C: Contact a Micromeritics service representative if this error message continues.

2478 | Error copying sequential data segment.

Cause: An internal processing and / or hardware error occurred while accessing a portion of a sample file.

Action: Confirm that the media being accessed does not contain errors.. Contact your Micromeritics service representative.

2479 | The instrument is busy performing an operation of which this application is unaware. Do you want to cancel? [Yes, No]

Cause: During initialization of the application, the status of the analyzer was found to be in

a different state than expected.

Action: Click **Yes** to cancel the operation in process and allow the analyzer to reset, then continue with initialization. Click **No** to cancel the initialization process.

If this error message continues, verify that files in the application directory structure are not being changed or removed.

2480 | File [n] cannot be analyzed. It is currently being edited.

Cause: An attempt was made to start an analysis using a file that is open for editing.

Action: Finish editing the file, save and close it, then start the analysis.

2481 | Error accessing the sample information file [n].

Cause: An unexplained error prevented access to this file.

Action: The hard disk drive may be corrupt. Run diagnostics.

2482 | File cannot be opened for writing.

Cause: An attempt was made to open a file currently being used.

Action: Locate the application using the file (in the Micromeritics application, use the Windows menu item to get a list of all open windows, one of which may contain this file).

2483 | An analysis cannot be performed on [n]. It is open for editing and contains errors.

Cause: An attempt was made to use a sample file containing errors that is currently open.

Action: Go to the window containing the file, correct the errors, then save it.

2484 | The edit session for [n] must be saved before the analysis. Save changes and continue with the analysis?

Cause: An attempt was made to start an analysis using a file that contains unsaved changes and is open for editing.

Action: Click **Yes** to save the changes, then proceed with the analysis. Click **No** to cancel the analysis, then continue editing the Sample Information file.

2485 | The service test file has an invalid status and cannot be used for this analysis.

Cause: The selected file has a status other than *No Analysis*.

Action: Select a different service test file, or create a new one and use **Replace All** to copy parameters from the file originally selected.

2486 | Could not construct [n] report type. Program will terminate.

Cause A: Full rights to the application's folders and files is required.

Action A: Contact a system administrator to have full rights granted.

Cause B: An internal processing and / or hardware error has occurred.

Action B: Contact your Micromeritics service representative.

2487 | Could not start report generator. Error code [n]. Program will terminate.

Cause A: Full rights to the application's folders and files is required.

Action A: Contact a system administrator to have full rights granted.

Cause B: An internal processing and / or hardware error has occurred.

Action B: Contact your Micromeritics service representative.

2488 | File [n] cannot be opened for editing.

Cause: The specified file is being used in another edit operation.

Action: Check the Windows list to locate the other edit session.

2489 | File [n] cannot be opened for writing.

Cause: The specified file in a *Save As* operation is already open for edit.

Action: Select a different file for the *Save As* operation.

2490 | No '.INI' file present. Application will terminate.

Cause: The ASCII .INI file containing initialization information and system options information used during program startup does not exist.

Action: Run the analyzer *Setup* program (located on the applications CD), select *Change analyzer setup* and enter the pertinent information.

2491 | Highlighted fields contain errors. Please correct the errors before dialog box.

Cause: The highlighted fields contain invalid entries. The window cannot be closed until all errors are corrected.

Action: Check the entries, correct the errors, then close the window.

2492 | This field's entry is invalid.

Cause: The highlighted field contains an invalid entry.

Action: Check the entry and correct the error.

2493 | An entry is required for this field.

Cause: This field requires a valid entry to proceed.

Action: Enter or select an appropriate value.

2494 | Value is out of the valid range.

Cause: The entered value in the highlighted field is outside the valid range of values.

Action: Check the entry, then either enter or select an appropriate value.

2495 | Value is out of the valid range. Enter a value between [n] and [n].

Cause: The entered value in the highlighted field is outside the valid range of values.

Action: Check the entry, then either enter or select an appropriate value.

2496 | Invalid number.

Cause: An invalid number was entered in the highlighted field.

Action: Check the entry, then either enter or select a valid number.

2497 | This field contains an invalid character.

Cause: An invalid character was entered in the highlighted field.

Action: Check the entry, then enter valid characters.

2498 | The requested change to the Sample's status is invalid at this time.

Cause: A request to change the file's status, for example, from *automatically collected* to *manually entered* could not be done.

Action: Contact your Micromeritics service representative. Record the name of the sample file in which the problem occurred.

2499 | Sequence number must contain at least 3 digits.

Cause: An attempt was made to enter a sequence number that did not contain at least three digits.

Action: Enter a sequence number that contains at least three digits.

2500 | All sample file names that can be created using the sequence number pattern already exist. You may want to modify the next sequence number.

Cause: No more sample information files can be created using the currently entered file name sequence number.

Action: Go to **Options > Default Method**, then enter another sequence number.

2501 | System resources have reached a dangerously low level. Please close some windows to avoid the loss of data.

Cause: A large number of windows are open and consuming the system resources available to all applications.

Action: Close one or more windows. Contact your Micromeritics service representative.

2502 | Error writing to file [n] during print. Error code [n].

Cause: An error occurred in the file being written to during a print operation.

Action: Ensure there is sufficient space on the drive containing the file.

2503 | Error converting file [n]. Cannot create DIO intermediate file.

Cause: An error occurred while printing a report to file.

Action: An attempt was made to replace a file that is read only or the computer login does not have permission to do so. Contact your IT Department.

2504 | Cannot create output file for sample [n].

Cause: There may be insufficient disk space.

Action: Ensure that sufficient space is available. Contact a Micromeritics service representative if this error message continues.

2505 | Error logger cannot be initialized. Error code [n]. Program will exit.

Cause: An internal processing error has occurred.

Action: Contact your Micromeritics service representative.

2506 | Output device [n] is not installed. Printing cannot be accomplished.

Cause: An internal processing error has occurred.

Action: Contact your Micromeritics service representative.

2508 | Overlay [n] was not found. It will not be included in the reports.

Cause: The specified overlay file could not be found.

Action: Ensure the file specified as an overlay exists.

2509 | Error opening file [n]. Reports cannot be produced.

Cause: An error occurred while the program was opening a file necessary to the report operation.

Action: Use the name given in the error message to investigate. Contact your Micromeritics service representative.

2510 | Error parsing reports from file [n]. Reports cannot be produced.

Cause A: One or more data entry fields in the sample file may contain an invalid character (such as a single quote or double quotes).

Action A: Review the data entry fields (for example, the *Sample* field), then remove the invalid character.

Cause B: The system was unable to create the usual temporary files during the report, possibly due to insufficient disk space.

Action B: Check the space available on the hard disk.

Cause C: An internal processing error occurred.

Action C: Contact your Micromeritics service representative.

2511 | Print job [n] has been canceled due to insufficient disk space. Delete unnecessary files and restart the report.

Cause: The disk drive does not have required space for the temporary file.
Action: Delete unnecessary files from the disk. At least five megabytes of free space is required for normal operation.

2512 | Print job [n] canceled.

Cause: The print job was canceled by the operator.
Action: None required.

2513 | Unable to read the calibration file [n].

Cause: An invalid calibration file was selected or cannot be read.
Action: Ensure the media containing the calibration file has no problems.

2514 | Unable to write the calibration file [n].

Cause: An attempt to save calibration data has failed due to possible media problems.
Action A: Ensure the destination location has no problems.
Action B: Choose an alternate media to save the calibration data.

2515 | Warning: Changing the calibration information will affect the performance of the instrument. Only qualified service personnel should do this. Do you wish to proceed?

Cause: The process of performing a calibration operation was started.
Action: Calibration operations should only be done by or under the direction of qualified service personnel.

2516 | Warning: Keeping a backup copy of the calibration data is recommended by Micromeritics. Would you like to do so now?

Cause: A calibration operation was performed and a backup copy is recommended.
Action: Go to **Unit [n] > Calibration > Save to File** to perform a calibration save operation.

2517 | Canceling this dialog will reset the calibration state to what it was when this dialog was first opened. Are you sure you want to cancel?

Cause: The calibration has not been accepted.
Action: If the calibration operation was successful, click **Accept**.

2520 | No data points available for reporting.

Cause: The selected sample file does not have collected data and cannot be used for reporting.
Action: Select a different sample file.

2521 | Unable to program controller.

Cause: A hardware malfunction has occurred.
Action: Contact your Micromeritics service representative.

2522 | Invalid controller application file.

Cause: The application's control file has been corrupted or deleted.
Action: Reinstall the analysis program.

2523 | Programming controller failed.

Cause: An internal processing and / or hardware error has occurred.
Action: Contact your Micromeritics service representative.

2524 | CRC check failed on programming controller.

Cause: An internal processing and / or hardware error has occurred.
Action: Contact your Micromeritics service representative.

2525 | Unknown error programming controller.

Cause: An internal processing and / or hardware error has occurred.
Action: Contact your Micromeritics service representative.

2526 | Controller download was not successful.

Cause: An internal processing and / or hardware error has occurred.
Action A: Contact your Micromeritics service representative.

2527 | Controller CRC error on boot block.

Cause: An internal processing and / or hardware error has occurred.
Action: Contact your Micromeritics service representative.

2528 | Controller DRAM error.

Cause: An internal processing and / or hardware error has occurred.
Action: Contact your Micromeritics service representative.

2529 | Controller Com 1: error.

Cause: An internal processing and / or hardware error has occurred.
Action: Contact your Micromeritics service representative.

2530 | Controller Com 2: error.

Cause: An internal processing and / or hardware error has occurred.
Action: Contact your Micromeritics service representative.

2531 | Controller debug port error.

Cause: An internal processing and / or hardware error has occurred.

Action: Contact your Micromeritics service representative.

2532 | The instrument contains a different software version. Do you want to reset it?

Cause: The application has discovered a different version of software operating in the analyzer.

Action: If there are no analyzers other than the one connected to the computer, click **Yes**, then allow the updated software to load.

2533 | Analyzer initialization failed.

Cause: An internal processing and / or hardware error has occurred.

Action: Contact your Micromeritics service representative.

2534 | Error opening file[n] for printing. Error Code [n].

Cause: An error occurred in the selected file for print output.

Action: Ensure that sufficient disk space is available.

2548 | System status 1 [n].

Cause: There was a problem establishing communication with the analyzer.

Action: Ensure that the communications cable is seated firmly in the Ethernet slot at the analyzer connection and the computer connection. Contact your Micromeritics service representative.

2548 | System status 2 [n].

Cause: There was a problem establishing communication with the analyzer.

Action: Ensure that the communications cable is seated firmly in the Ethernet slot at the analyzer connection and the computer connection. Contact your Micromeritics service representative.

2549 | Error accessing online manual file [n].

Cause: The operator's manual file could not be located.

Action A: Reinstall the application.

Action B: Copy the contents of the manual folder from the setup CD to the application directory.

2550 | Attempts to acquire the instrument's status timed out.

Cause: There was a problem establishing communication with the analyzer.

Action: Ensure that the communications cable is seated firmly in the Ethernet slot at the analyzer connection and the computer connection. Contact your Micromeritics service representative.

2551 | Cannot access web page [n].

Cause: The Micromeritics web page for DFT models cannot be accessed. This could be caused by an ISP problem of high internet traffic.

Action: Try the operation later.

6000 | An error occurred while loading the application control information. Data entry cannot be performed. (Code [n]).

Cause: An error occurred accessing the control information disk file required by this application.

Action: The disk drive may have failed or be corrupt. Run diagnostics on the disk drive.

6001 | Unable to establish the TCP connection with the instrument.

Cause: A communications problem between the computer and the analyzer has occurred.

Action A: Check the cable connection between the computer and the analyzer

Action B: Go to **Unit [n] > Unit Configuration** and verify that the TCP/IP configuration for the computer and the analyzer are correct.

Action C: Exit the application, and turn off the analyzer. Then turn on the analyzer and restart the application. Contact a Micromeritics service representative if this error message continues.

6002 | Configured serial number does not match instrument.

Cause: An incorrect serial number was entered when installing the software.

Action: Exit the application. Access the *Setup* program and remove the incorrect analyzer. Then use the *Add an Analyzer* option in the *Setup* program to add the correct serial number for the controlling unit. Contact a Micromeritics service representative if this error message continues.

6003 | The instrument [n] is not calibrated.

Cause: Calibration data for the selected unit was not found

Action: Go to **Unit > Calibration**. Select the appropriate Calibration menu item or load a saved calibration.

6110 | Error accessing the sample information file [n].

Cause: There was an error opening a file.

Action: Code 5: There is a problem with the computer login permissions. Consult your IT department.

Code 2: File not found. Select a different file name.

6111 | File [n] cannot be analyzed. It is currently being edited.

Cause: An open file was selected. This message is informational-only.

Action: Click **OK** to close the error message window. Then continue editing the file, save and close it; or click **Browse** and choose a different file.

6112 | File [n] cannot be opened. It is currently being setup for analysis.

Cause: An open file was selected that is currently being used for analysis.

Action: Select a different file.

6113 | An analysis cannot be performed on [n]. It is open for editing and contains errors

Cause: The selected analysis file contains errors and is open for editing.

Action: Finish editing the file, save, and close it, or choose a different file. Then restart the analysis.

6114 | The edit session for [n] must be saved before the analysis. Save changes and proceed with the analysis?

Cause: An attempt was made to start an analysis using a file that contains unsaved changes and is still open.

Action: Click **Yes** to save the changes and proceed with the analysis. Click **No** to cancel the analysis and continue editing the file, save and close it; or click **Browse** and choose a different file.

6120 | Unable to read the calibration file [n].

Cause: The selected calibration file is not valid or cannot be read.

Action: Ensure the media containing the calibration file has no problems.

6121 | Unable to write the calibration file [n].

Cause: An attempt to save calibration data has failed due to possible media problems.

Action A: Confirm the media containing the calibration file has no problems.

Action B: Choose an alternate media to save the calibration data.

6122 | File contains calibration data for a different unit [n].

Cause: A calibration file from a different unit was loaded.

Action: Load a file for the current unit or go to **Unit > Calibration** and select the appropriate menu item.

6123 | The device has no calibration data for the selected insert.

Cause: A calibration report was produced for an insert that has not been calibrated.

Action: Perform a volume calibration for the insert or produce a report for a different insert.

6126 | The cell and expansion volumes must be positive. Enter positive values and recalibrate.

Cause: According to the calibration data, the cell volume or expansion volume for the selected insert is zero or a negative value

Action: Perform these steps:

1. Select *Setup > Calibration Data*.
2. In the *Cell volume* field, enter the volume of the sample cell (or insert).
3. In the *Expansion volume* field, enter half of the sample cell volume.
4. Perform a volume calibration.

6127 | The entered calibration volume is < 10% of the cell volume. The resulting calibration may be inaccurate.

Cause A: An incorrect volume was entered for the calibration standard.

Action A: Correct the volume entry.

Cause B: The calibration standard is too small for the cell.

Action B: Use a larger calibration standard.

6160 | Device in recognizable state. Analysis canceled.

Cause: The application was closed during an analysis. When the application was restarted, the analysis had been canceled.

Action: None required. The data collected up to the point of cancellation is saved in the sample file.

6161 | The sample file [n] is already present in the sequence.

Cause: An attempt was made to insert an existing file into the Sample File list.

Action: None required. The same file cannot be inserted into the list multiple times.

6162 | The sequence list is full.

Cause: An attempt was made to add another file to the Sample File list for sequenced analyses when the list already contains eight entries.

Action A: Run the sequence analysis with the current list and include the preferred file in the next sequence analysis.

Action B: Remove one of the files from the list, then add the preferred file.

6163 | The sample file has an invalid status and cannot be used for analysis.

Cause: A sample file with a status other than *No Analysis* was selected.

Action: Select a sample file that has not been used in an analysis.

6164 | FoamPyc analyses cannot be done on a 1 cm³ unit.

Cause: An attempt was made to perform a FoamPyc analysis on a unit that does not sup-

port it. FoamPyc analyses cannot be performed on a unit with a 1 cm³ or 2L sample cell.

Action A: Start the analysis on a different unit.

Action B: Close the analysis window, open the sample file, and select **Standard Method**. Then restart the analysis.

6165 | Failure to fill sample cup.

Cause: There was insufficient pressure to allow filling within five minutes during an analysis

Action: Increase the regulator pressure or, if there is insufficient helium in the tank, obtain a new tank of helium.

6166 | Pressure overrange

Cause A: A pressure overrange occurred during an analysis because the regulator pressure is set too high.

Action A: Adjust the pressure so that it is equal to the higher of the two fill pressures specified in the analysis parameters plus 2.0 psig.

Cause B: A pressure overrange occurred during an analysis because an error occurred in the pressure measurement electronics.

Action B: Contact your Micromeritics service representative.

6167 | Pressure underrange

Cause: A pressure underrange occurred during an analysis because an error occurred in the pressure measurement electronics.

Action: Contact your Micromeritics service representative.

6168 | Pressure failed to equilibrate.

Cause A: The sample being analyzed failed to equilibrate in 1000 seconds.

Action A: Check the system carefully for leaks following the instructions in the instrument operator manual. Ensure the sample is properly prepared before performing an analysis.

Cause B: Sample (foams, organics, etc.) absorbs helium slowly.

Action B: Set the equilibration rate to progressively higher values until reasonable equilibration times (15 sec to 120 sec) are achieved.

6169 | The instrument lost power during analysis.

Cause: A power failure occurred and when power resumed, the automatic operation was canceled.

Action: Restart the automatic operation.

6170 | The measured volume is < 10% of the cell volume. Results may be inaccurate.

Cause: Not enough sample was placed in the sample cup to give an accurate reading.
Action: Rerun the sample using enough material to occupy the maximum amount of the nominal cell chamber volume

6171 | Valve failed to respond.

Cause: The instrument valves failed to operate.
Action: Contact your Micromeritics service representative.

6200 | At least one report item must be selected. Press **Cancel if you do not want a report.**

Cause: No reports were selected in the *Selected Reports* list. No output could be produced.
Action: Ensure that at least one report is selected for the sample and re-submit the sample for reporting, or click **Cancel**.

6201 | No data available in [n] for reporting.

Cause: The requested report file does not contain collected data.
Action: Use the file in an analysis before requesting reports.

6202 | Total solids concentration is invalid; liquid density is greater than or equal to solids density.

Cause: A report was requested on a file containing invalid densities for *Total Solids Concentration*.
Action A: Specify appropriate densities for liquid and solids.
Action B: Do not request that total solids concentration be reported.

ERROR MESSAGES FOR 1340 ACCUPYC KEYPAD ONLY

Press **CHOICE** to cycle through the messages and data. To delete the message, press **CLEAR**. Messages that are not cleared will remain in the queue until the next analysis or calibration is performed; at that time, any remaining messages will be cleared automatically.

- NN = Number of cycles completed
- ZZ = Number of cycles requested

Add Unit

Cause A: A new analysis module has been attached to the instrument where previously a different module had been attached.

Action A: Press **Choice** and select *Yes* to add the new analysis module.

Cause B: An incorrect serial number was read by the analysis module.

Action B: Press **Choice** and select *No* to use the serial number and calibration information stored in the command module. Contact a Micromeritics service representative if this error message continues.

ANLSERR: Eq failure — NN/ZZ cycles completed

Cause A: The sample being analyzed failed to equilibrate in 1000 seconds.

Action A: Check the system carefully for leaks following the instructions in the instrument operator manual. Ensure the sample is properly prepared before performing an analysis.

Cause B: Sample (foams, organics, etc.) absorbs helium slowly.

Action B: Set the equilibration rate to progressively higher values until reasonable equilibration times (15 sec to 120 sec) are achieved.

ANLSERR: Fill failure — NN/ZZ cycles complete

Cause: There was insufficient pressure to allow filling within five minutes during an analysis

Action: Increase the regulator pressure or, if there is insufficient helium in the tank, obtain a new tank of helium.

ANLSERR: Overrange — NN/ZZ cycles completed

Cause A: A pressure overrange occurred during an analysis because the regulator pressure is set too high.

Action A: Adjust the pressure so that it is equal to the higher of the two fill pressures specified in the analysis parameters plus 2.0 psig.

Cause B: A pressure overrange occurred during an analysis because an error occurred in the pressure measurement electronics.

Action B: Contact your Micromeritics service representative.

ANLSERR: Underrange — NN/ZZ cycles completed

Cause: A pressure underrange occurred during an analysis because an error occurred in the pressure measurement electronics.

Action: Contact your Micromeritics service representative.

Automatic operation has been canceled

Cause: The automatic operation has been canceled.

Action: Wait for the termination process to complete or end the termination process by pressing **Alt + CLEAR** two more times.

CAL_ERR: Reset Pressure Cal. ?

Cause: The calibration information could not be read from the command or analysis module.

Action A: Select *Yes* and press **Enter** to reset the pressure and temperature calibration to nominal values. Resetting to nominal may restore normal readings but a proper calibration should be performed by a service technician.

Action B: Select *No* to avoid resetting the calibration. The instrument will be unresponsive.

CAL_ERR: Temperature Calibration Failed

Cause: The temperature calibration was unsuccessful.

Action: Contact your Micromeritics service representative.

CAL1ERR: Eq failure — NN/ZZ cycles complete

Cause: The empty cell chamber failed to equilibrate in 1000 seconds during the first pass of calibration.

Action: Check the system for leaks.

CAL1ERR: Fill failure NN/ZZ cycles completed

Cause: There was insufficient pressure to allow filling within five minutes during the first pass of calibration.

Action: Open the tank valves if shut, increase the regulator pressure or, if there is insufficient helium in the tank, obtain a new tank of helium. (Minimum recommended tank pressure is 200 psig.)

CAL1ERR: Overrange — NN/ZZ cycles completed

Cause A: A pressure overrange occurred during the first pass of calibration because the regulator pressure is set too high.

Action A: Adjust the pressure so that it is equal to the higher of the two fill pressures specified in the analysis parameters plus 2.0 psig.

Cause B: A pressure overrange occurred during the first pass of calibration because an error

occurred in the pressure measurement electronics.

Action B: Contact your Micromeritics service representative.

CAL1ERR: Underrange — NN/ZZ cycles complete

Cause: A pressure underrange occurred during the first pass of calibration because an error occurred in the pressure measurement electronics.

Action: Contact your Micromeritics service representative.

CAL2ERR: Eq failure — NN/ZZ cycles completed

Cause: The calibration standard failed to equilibrate in 1000 seconds during the second pass of calibration.

Action: Check the system for leaks.

CAL2ERR: Fill failure — NN/ZZ cycles completed

Cause: There was insufficient pressure to allow filling within five minutes during the second pass of calibration.

Action: Open the tank valves if shut, increase the regulator pressure or, if there is insufficient helium in the tank, obtain a new tank of helium. (Minimum recommended tank pressure is 200 psig.)

CAL2ERR: Overrange — NN/ZZ cycles completed

Cause A: A pressure overrange occurred during the second pass of calibration because the regulator pressure is set too high.

Action A: Adjust the pressure so that it is equal to the higher of the two fill pressures specified in the analysis parameters plus 2.0 psig.

Cause B: Adjust the pressure so that it is equal to the higher of the two fill pressures specified in the analysis parameters plus 2.0 psig.

Action B: Contact your Micromeritics service representative.

CAL2ERR: Underrange — NN/ZZ cycles completed

Cause: A pressure underrange occurred during the second pass of calibration because an error occurred in the pressure measurement electronics.

Action: Contact your Micromeritics service representative.

DATA_ERR: Chamber volumes must be > 0

Cause: According to the calibration data, the cell volume or expansion volume for the selected insert is zero or a negative value

Action: Perform these steps:

1. Select *Setup > Calibration Data*.

2. In the *Cell volume* field, enter the volume of the sample cell (or insert).
3. In the *Expansion volume* field, enter half of the sample cell volume.
4. Perform a volume calibration.

DATA_ERR: No data to compute

Cause A: An automatic operation was canceled before a complete cycle could be completed.

Action A: Restart the automatic operation.

Cause B: All the cycles have been excluded in review mode.

Action B: Return to review mode and include some cycles.

DTA_WRN: Cal std — 10% of full-scale

Cause A: You entered a value for the calibration standard that was less than 10% of the nominal cell chamber volume. Resulting data may be inaccurate.

Action A: Be sure you enter the value recorded on the Calibration Standard case.

Cause B: You used an inappropriate calibration standard for the nominal cell chamber.

Action B: Use a calibration standard of sufficient size (calibration standards are available from Micromeritics). The calibration standard should occupy at least 10% of the nominal cell chamber volume and the more nearly filled the cell is, the better the calibration.

DTA_WRN: Volume — 10% of full-scale

Cause: There was not enough sample placed in the sample cup to give an accurate reading.

Action: Rerun the sample using enough material to occupy the maximum amount of the nominal cell chamber volume.

HW_ERR: Calibration could not be read

Cause: The calibration information could not be read from the command or analysis module.

Action: Close the application and cycle power on the instrument. Contact a Micromeritics service representative if this error message continues.

MAN_ERR: Pressure overrange

Cause: The fill valve was left open until the maximum system pressure was exceeded.

Action: Close the fill valve and open the vent and expansion valves. Allow the pressure to stabilize.

No A.C. Found

Cause: The control module cannot detect an analysis module.

Action: Contact your Micromeritics service representative.

No collected data to report, or all cycles excluded

Cause: You requested a report in which there is either no data available or data have been excluded via review mode.

Action: Initiate an automatic operation or return to review mode and include at least one cycle.

Printer port not responding

Cause: Printer port not responding

Action: Check to make sure the printer is properly connected to the pycnometer, is turned on, and is online.

Queuing print job [ESCAPE] to cancel

Cause: Status message displayed when a report is being printed.

Action: None; this is a status message only.

Reset to factory defaults

Cause: The . (period) key was pressed at startup and the instrument was reset. Data files and HTML reports have been erased. Setup options have been returned to default values.

Action: Review setup options.

Sending line (line number) [ESCAPE] to cancel

Cause: Status message displayed when data are being transmitted.

Action: None; this is a status message only.

SYS_ERR: Power Fail — NN/ZZ Cycles Completed

Cause: A power failure occurred and when power resumed, the automatic operation was canceled.

Action: Restart the automatic operation if desired.

TRN_ERR: Timeout failed to respond

Cause: The receiving device took longer than 10 seconds to acknowledge receipt of data from the pycnometer.

Action: Make sure the receiving device is properly connected to the pycnometer RS-232 port and is turned on. Verify that the serial I/O parameters controlling the receiving device correspond with the data transmission parameters in the set up mode.

Updating Unit [n] failed: Press [CLEAR]

Cause: One of the analysis modules has malfunctioned.

Action: Press CLEAR and follow the instructions displayed in the keypad window. After

disconnecting the faulty unit (as instructed), you may reconnect the control module with the remaining analysis module(s) and continue using your system.

USR_ERR: Cal std 10% of full-scale

Cause: You tried to enter a calibration standard volume that is less than 10% of the nominal full-scale volume.

Action: Enter a volume that represents at least 10% of the nominal cell chamber volume.

USR_ERR: No data to review

Cause: You tried to review data for an automatic operation when there were no data to review.

Action: Abandon request.

USR_ERR: Number of cycles must be ≥ 5

Cause: You tried to enable run precision without increasing the number of runs to at least five.

Action: Increase the number of runs to five or abandon request.

USR_ERR: Out of range

Cause: You tried to enter a value that is out of the valid range.

Action: Enter a value in the specified range.

USR_ERR: Pressure overrange

Cause: A pressure overrange occurred but was left uncorrected.

Action: Return to manual mode and vent the system.

Transmission port not responding

Cause: The receiving device took longer than five seconds to acknowledge receipt of data from the pycnometer.

Action: Make sure the receiving device is properly connected to the pycnometer RS-232 port and is turned on. Verify that the serial I/O parameters controlling the receiving device correspond with the data transmission parameters in the set up mode.

Transmission port waiting for Xon

Cause: The receiving device stopped transmission by sending an Xoff, and hasn't resumed the transmission by sending an Xon.

Action: None; when the receiving device is ready for more data, it should send the pycnometer an Xon.

SYS_ERR: Power Fail — NN/ZZ Cycles Completed

Cause: A power failure occurred and when power resumed, the automatic operation was canceled.

Action: Restart the automatic operation if desired.

TRN_ERR: Timeout failed to respond

Cause: The receiving device took longer than 10 seconds to acknowledge receipt of data from the pycnometer.

Action: Make sure the receiving device is properly connected to the pycnometer RS-232 port and is turned on. Verify that the serial I/O parameters controlling the receiving device correspond with the data transmission parameters in the set up mode.

Updating Unit [n] failed: Press [CLEAR]

Cause: One of the analysis modules has malfunctioned.

Action: Press CLEAR and follow the instructions displayed in the keypad window. After disconnecting the faulty unit (as instructed), you may reconnect the control module with the remaining analysis module(s) and continue using your system.

USR_ERR: Cal std 10% of full-scale

Cause: You tried to enter a calibration standard volume that is less than 10% of the nominal full-scale volume.

Action: Enter a volume that represents at least 10% of the nominal cell chamber volume.

USR_ERR: No data to review

Cause: You tried to review data for an automatic operation when there were no data to review.

Action: Abandon request.

USR_ERR: Number of cycles must be ≥ 5

Cause: You tried to enable run precision without increasing the number of runs to at least five.

Action: Increase the number of runs to five or abandon request.

USR_ERR: Out of range

Cause: You tried to enter a value that is out of the valid range.

Action: Enter a value in the specified range.

USR_ERR: Pressure overrange

Cause: A pressure overrange occurred but was left uncorrected.

Action: Return to manual mode and vent the system.

Blank Page

B CALCULATIONS

ANALYSIS

For derivation, see ["Sample Volume Equation Derivation" on page C - 1.](#)

10, 100, AND 350 CM³ UNITS

$$V_s = V_c - \frac{V_x}{\frac{P_1}{P_2} - 1}$$

$$\rho_s = \frac{m_s}{V_s}$$

where

V_c	=	sample chamber volume
V_x	=	expansion chamber volume
V_s	=	sample volume
m_s	=	sample mass
ρ_s	=	sample density
P_1	=	gauge pressure after fill
P_2	=	gauge pressure after expansion

1 CM³ AND 2000 CM³ UNITS

$$V_s = V_c - V_x \left(\frac{P_1}{P_2} - 1 \right)$$

$$\rho_s = \frac{m_s}{V_s}$$

where

V_c	=	sample chamber volume
V_x	=	expansion chamber volume
V_s	=	sample volume
m_s	=	sample mass
ρ_s	=	sample density
P_1	=	gauge pressure after fill
P_2	=	gauge pressure after expansion

CALCULATIONS FOR FOAMPYC METHODS

METHOD A: COMPUTED OPEN CELL FRACTION

$$\text{OpenCellPct} = \frac{\text{GeomVol} - V_s - \text{VolCellsCutOpen}}{\text{GeomVol}} \times 100$$

$$\text{ResinPlusClosedCellPct} = 100 - \text{OpenCellPct}$$

If cell measure is **Chord Length**,

$$\text{VolCellsCutOpen} = \text{ActiveArea} \times \frac{\text{ChordLength}}{1.14}$$

If cell measure is **Diameter**,

$$\text{VolCellsCutOpen} = \text{ActiveArea} \times \frac{\text{CellDiam}}{1.4515}$$

METHOD B: MEASURED OPEN CELL FRACTION

$$\text{VolCellsCutOpen} = V_s[1] - V_s[2]$$

$$\text{ResinPlusClosedCellVol} = V_s[1] + \text{VolCellsCutOpen}$$

$$\text{OpenCellVol} = \text{GeomVol} - \text{ResinPlusClosedCellVol}$$

$$\text{ResinPlusClosedCellPct} = \frac{\text{ResinPlusClosedCellVol}}{\text{GeomVol}} \times 100$$

$$\text{OpenCellPct} = \frac{\text{OpenCellVol}}{\text{GeomVol}} \times 100$$

where

$$\begin{aligned}
 V_s[1] &= V_s \text{ from the first analysis (before recutting)} \\
 V_s[2] &= V_s \text{ from the second analysis (after recutting)}
 \end{aligned}$$

METHOD C: UNCORRECTED OPEN CELL FRACTION

$$\text{OpenCellVol} = \text{GeomVol} - V_s$$

$$\text{OpenCellPct} = \frac{\text{OpenCellVol}}{\text{GeomVol}} \times 100$$

METHOD D: COMPRESSIBILITY TEST

Quantities appended with [i] are for cycle i, where i goes from 1 up to the number of cycles.

$$\Delta V_{P_1}[i] = \frac{V_s[i-1] - V_s[i]}{P_1[i-1] - P_1[i]}$$

$$\Delta V_{P_2}[i] = \frac{V_s[i-1] - V_s[i]}{P_2[i-1] - P_2[i]}$$

$$\text{AvgVolChangeP1} = \text{avg}(\Delta V_{P_1}[i]) \text{ for all included } i$$

$$\text{AvgVolChangeP2} = \text{avg}(\Delta V_{P_2}[i]) \text{ for all included } i$$

$$\text{PctAvgVolChangeP1} = \frac{\text{AvgVolChangeP1}}{\text{GeomVol}} \times 100$$

$$\text{PctAvgVolChangeP2} = \frac{\text{AvgVolChangeP2}}{\text{GeomVol}} \times 100$$

METHOD E: FRACTURE TEST

$$\Delta \text{Vol} = V_s[3] - V_s[1]$$

$$\text{PctFracturedCells} = \frac{\Delta \text{Vol}}{\text{GeomVol}} \times 100$$

where

$$\begin{aligned}
 V_s[1] &= V_s \text{ for the first (prefracture) cycle} \\
 V_s[3] &= V_s \text{ for the third (postfracture) cycle}
 \end{aligned}$$

CALIBRATION

Volume calibration uses the ultra-precise method of separate adjustments for the offset and scale factor.

VOLUME OFFSET

$$V_c = V_{celprev} - V_{sampempty}$$

$-V_{sampempty}$ is reported as the offset in volume calibration reports.

VOLUME SCALE

$$V_c = V_{celprev} \left(\frac{V_{calib}}{V_{sampball}} \right)$$

$$V_x = V_{expprev} \left(\frac{V_{calib}}{V_{sampball}} \right)$$

$\left(\frac{V_{calib}}{V_{sampball}} \right)$ is reported as the scale factor in volume calibration reports.

where

V_c	=	sample chamber volume
$V_{celprev}$	=	previously stored cell volume
$V_{sampempty}$	=	average V_{samp} from volume offset calibration analysis (no calibration ball)
V_{calib}	=	calibration ball volume
$V_{sampball}$	=	average V_{samp} from volume scale calibration analysis (with calibration ball)
V_x	=	expansion chamber volume
$V_{expprev}$	=	previously stored expansion volume

GEOMETRIC VOLUME AND ACTIVE AREA

Geometric volume of the sample is calculated based on the sample shape; for Method A, Active area is also calculated.

CUBE

$$\text{GeomVol} = \text{EdgeLength}^3 \times \text{NumPieces}$$

$$\text{ActiveArea} = \text{EdgeLength}^2 \times (6 - \text{NumSkins}) \times \text{NumPieces}$$

CYLINDER

$$\text{GeomVol} = \pi \times \frac{\text{Diam}^2}{4} \times \text{Height} \times \text{NumPieces}$$

$$\text{ActiveArea} = \left[\pi \times \text{Diam} \times \text{Height} + \frac{\pi}{4} \times \text{Diam}^2 \times (2 - \text{NumSkins}) \right] \times \text{NumPieces}$$

RECTANGLE

$$\text{GeomVol} = \text{LongEdge} \times \text{ShortEdge} \times \text{RemainEdge} \times \text{NumPieces}$$

$$\text{ActiveArea} = [(\text{LongEdge} \times \text{RemainEdge} \times (2 - \text{NumLargeSkins}) + \text{ShortEdge} \times \text{RemainEdge} \times (2 - \text{NumSmallSkins}) + \text{LongEdge} \times \text{ShortEdge} \times (2 - \text{NumRemainSkins}))] \times \text{NumPieces}$$

RUN PRECISION

Run precision requires at least five runs. Run precision criterion is met when the sample volumes calculated for the four most recent previous runs fall within the specified error band for the current run's sample volume. The error band is a specified percentage of the nominal volume of the sample chamber (1, 10, 100, 350 and / or 2000 cm³).

$V_s[0]$ to $V_s[4]$ are the five most recent sample volumes, $V_s[4]$ being the most recent.

$$\text{ErrBand} = \text{PctFullScale} \times \frac{V_{\text{nominal}}}{100}$$

where

$$V_{\text{nominal}} = \text{nominal sample cell volume}$$

If $(|V_s[i] - V_s[4]| \leq \text{ErrBand})$ for $i = 0$ to 3, run precision is achieved.

TOTAL PORE VOLUME

Total pore volume is per gram of sample.

$$\text{TotalPoreVol} = \frac{\rho_s - \rho_{\text{bulk}}}{\rho_s \times \rho_{\text{bulk}}}$$

where

$$\rho_{\text{bulk}} = \text{entered bulk density}$$

TOTAL SOLIDS CONCENTRATION

$$\text{WeightPctSolids} = 1 - \frac{\rho_{liq}}{\rho_s} \times \frac{\rho_{sol}}{\rho_{sol} - \rho_{liq}} \times 100$$

where

ρ_{liq} = entered liquid density

ρ_{sol} = entered solid density

ρ_s = sample density

SPC REPORT VARIABLES

REGRESSION CHART

The line of best fit for the Regression Chart is calculated by the usual least squares method. If there is only a single point, or all N points have the same x-value, there can be no line of best fit in the standard form.

$$\bar{X} = \frac{\sum x_i}{N}$$

$$\bar{Y} = \frac{\sum y_i}{N}$$

$$\text{Slope} = \frac{\sum (x_i - \bar{x})(y_i - \bar{y})}{\sum (x_i - \bar{x})^2}$$

$$\text{Intercept} = \bar{y} - \text{Slope} \cdot \bar{x}$$

The coefficient of correlation for this line also is calculated in the usual way¹⁾ .

$$\sigma_x = \sqrt{\frac{\sum (x_i - \bar{x})^2}{N}}$$

$$\sigma_y = \sqrt{\frac{\sum (y_i - \bar{y})^2}{N}}$$

$$\text{Cov}(x, y) = \frac{\sum (x_i - \bar{x})(y_i - \bar{y})}{N}$$

$$\text{CorrelationCoef} = \frac{\text{Cov}(x, y)}{\sigma_x \sigma_y}$$

¹⁾ Mathematical Handbook for Scientists and Engineers, G.A., Korn and T.M. Korn, McGraw Hill, Sec. 18.4 (1968)

CONTROL CHART

$$\text{Mean} = \frac{\sum y_i}{N}$$

$$\text{StdDev} = \sqrt{\frac{\sum (y_i - \text{Mean})^2}{N - 1}}$$

$$\text{CoefVar} = \frac{\text{StdDev}}{\text{Mean}}$$

RESIN VOLUME

$$\text{ResinVol} = \frac{m_s}{\text{ResinDensity}}$$

$$\text{ResinVolPct} = \frac{\text{ResinVol}}{\text{GeomVol}} \times 100$$

where

$$m_s = \text{sample mass}$$

PERCENT POROSITY

$$\text{percent porosity} = (\rho_s - \rho) \div \rho_s$$

SPECIFIC GRAVITY

$$SG = \rho_s \div \rho_w$$

where

$$\rho_w = \text{water density at analysis temperature}$$

ASPHALT DENSITY CALCULATIONS

Sample volume at 60 °F is found by multiplying the measured volume by the asphalt volume correction factor.

$$V(60) = \alpha(T)V_{\text{measured}}$$

where

$$\alpha(T) = 1.0211326242 - 3.548988118 \times 10^{-4}T + 4.498813 \times 10^{-8}T^2$$

and T is the analysis temperature in degrees Fahrenheit.

Sample density at 60 °F is

$$p(60) = m / V(60)$$

Specific gravity at 60 °F is calculated by dividing the adjusted sample density by the density of water at 60 °F.

$$SG(60) = p(60) \div \rho_{\text{H}_2\text{O}}(60)$$

where

$$\rho_{\text{H}_2\text{O}} = 0.990170\text{g} / \text{cm}^3$$

Note that the density of water at the analysis temperature is not required for this calculation.

Blank Page

C SAMPLE VOLUME EQUATION DERIVATION

10, 100, AND 350 CM³ UNITS

The AccuPyc II is a gas displacement pycnometer which measures the volume of solid objects of irregular or regular shape whether powdered or in one piece. A greatly simplified diagram of the instrument is shown below.

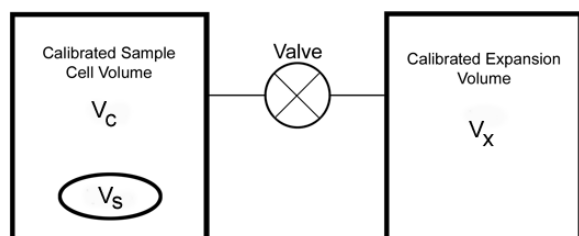

Sample volume is determined from the known cell and expansion volumes and from measured pressures.

The cell and expansion chamber are initially at ambient pressure and the valve is closed. The cell is then charged to an elevated pressure.

The ideal gas law gives:

$$P_1(V_c - V_s) = n_c RT \quad (1)$$

where

n_c = moles of gas in the sample cell

R = the gas constant

T = temperature

V_c = cell volume

V_s = sample volume

V_x = expansion volume

P_1 = initial cell pressure

Expansion volume:

$$P_a V_x = n_x RT \quad (2)$$

where

P_a = ambient pressure

n_x = moles of gas in the expansion volume

When the valve is opened, the pressure falls to an intermediate value, P_2 , and mass balance yields:

$$P_2(V_c - V_s + V_x) = n_cRT + n_xRT \quad (3)$$

Substituting from equations (1) and (2) into (3):

$$P_2(V_c - V_s + V_x) = P_1(V_c - V_s) + P_aV_x \quad (4)$$

or

$$(P_2 - P_1)(V_c - V_s) = (P_a - P_2)V_x \quad (5)$$

then

$$V_c - V_s = \frac{P_a - P_2}{P_2 - P_1} V_x \quad (6)$$

Adding and subtracting P_a in the denominator and rearranging gives

$$-V_s = -V_c + \frac{P_a - P_2}{P_2 - P_a - P_1 + P_a} V_x \quad (7)$$

Dividing by $(P_a - P_2)$ in both the numerator and denominator

$$V_s = V_c - \frac{V_x}{-1 - \left(\frac{P_1 - P_a}{P_a - P_2}\right)} \quad (8)$$

or

$$V_s = V_c - \frac{V_x}{\left(\frac{P_1 - P_a}{P_2 - P_a}\right) - 1} \quad (9)$$

Using gauge pressure defined as:

$$P_{ig} = P_i - P_a \quad (10)$$

equation (9) is rewritten as:

$$V_s = V_c - \frac{V_x}{\frac{P_{1g}}{P_{2g}} - 1} \quad (11)$$

1 CM³ AND 2000 CM³ UNITS

The 1 cm³ and 2000 cm³ pycnometers operate by filling the expansion chamber while the sample cell remains at ambient pressure. After P_1 is equilibrated, the expansion valve opens to allow gas to expand into the sample chamber and P_2 is equilibrated.

For the 1 cm³ and 2000 cm³ pycnometers, equation (1) becomes

$$P_1 V_x = n_x RT$$

and equation (2) becomes

$$P_a (V_c - V_s) = n_c RT$$

A derivation similar to that above yields the working equation for the 1 cm³ and 2000 cm³ pycnometers

$$V_s = V_c - V_x \left(\frac{P_{1g}}{P_{2g}} - 1 \right)$$

Blank Page

D TRANSMITTED DATA

Analysis and calibration data can be transmitted in a single column or spreadsheet with data in ASCII delimited format. Units are displayed as:

Data Units

Type	Measurement
Date	DD/MM/YY
Time	HH:MM:SS
Pressure	psig
Temperature	°C
Elapsed Time	seconds

ANALYSIS REPORT

Analysis Report - Spreadsheet

Record Number	Description	Form
1	Version Number	20 characters
2	Serial Number	1 integer
3	Report type = analysis	8 characters
4	Start (reported on one line as ASCII comma delimited data) <ul style="list-style-type: none"> • 4a. Date • 4b. Time 	8 characters (each)
5	Stop (reported on one line as ASCII comma delimited data) <ul style="list-style-type: none"> • 5a. Date • 5b. Time 	8 characters (each)
6	Temperature	1 floating point
7	Description line 1	20 characters
8	Description line 2	20 characters
9	Sample IDs	20 characters
10	Sample mass	1 floating point
11	Number of purges	1 integer
12	Equilibration rate	1 floating point

Analysis Report - Spreadsheet (continued)

Record Number	Description	Form
13	Chamber Insert: <ul style="list-style-type: none"> • 0 = None • 1 = 10 cm³ (100 cm³ unit) 1 cm³ (10 cm³ unit) 0.1 cm³ (1 cm³ unit) • 2 = 35 cm³ (100 cm³ unit) 3.5 cm³ (10 cm³ unit) 	1 integer
14	Cell volume	1 floating point
15	Expansion volume	1 floating point
16	Average volume	1 floating point
17	Volume standard deviation	1 floating point
18	Average density	1 floating point
19	Density standard deviation	1 floating point
20	Number of runs	1 integer
21	Run precision <ul style="list-style-type: none"> • 0 = Disabled • 1 - Enabled 	1 floating point
22	Percent full scale	1 floating point
23	Carriage return / Line feed	
24	Carriage return / Line feed	
25	Carriage return / Line feed	
26	Run number and pressure (reported on one line as ASCII comma delimited data)	
26a	Run number	1 integer
26b	P1	1 floating point
26c	P2	1 floating point
26d	Include in average calculation <ul style="list-style-type: none"> • 0 = Excluded • 1 = Included 	1 integer
26e	Elapsed time	1 unsigned integer

Analysis Report - Spreadsheet (continued)

Record Number	Description	Form
26f	Volume	1 floating point
26g	Volume deviation	1 floating point
26h	Density	1 floating point
26i	Density deviation	1 floating point
27	Temperature (all temperature data)	1 floating point

CALIBRATION REPORT
Calibration Report - Single Column

Record Number	Description	Form
1	Version Number	20 characters
2	Serial Number	1 integer
3	Report type = calibration	11 characters
4	Start (reported on one line as ASCII comma delimited data) <ul style="list-style-type: none"> • 4a. Date • 4b. Time 	8 characters (each)
5	Stop (reported on one line as ASCII comma delimited data) <ul style="list-style-type: none"> • 5a. Date • 5b. Time 	8 characters (each)
6	Temperature	1 floating point
7	Calibration standard size	1 floating point
8	Number of purges	1 integer
9	Equilibration rates	1 floating point

Calibration Report - Single Column (continued)

Record Number	Description	Form
10	Chamber Insert: <ul style="list-style-type: none"> • 0 = None • 1 = 10 cm³ (100 cm³ unit) 1 cm³ (10 cm³ unit) 0.1 cm³ (1 cm³ unit) • 2 = 35 cm³ (100 cm³ unit) 3.5 cm³ (10 cm³ unit) 	1 integer
11	Average cell volume	1 floating point
12	Cell volume standard deviation	1 floating point
13	Average expansion volume	1 floating point
14	Expansion volume standard deviation	1 floating point
15	Number of runs	1 integer
16	P1 (all P1 data)	1 floating point
17	P2 (all P2 data)	1 floating point
18	P1* (all P1* data)	1 floating point
19	P2* (all P2* data)	1 floating point
20	Include in average calculation <ul style="list-style-type: none"> • 0 = Excluded • 1 = Included 	1 integer

Calibration Report - Spreadsheet

Record Number	Description	Form
1	Version Number	20 characters
2	Serial Number	1 integer
3	Report type = calibration	11 characters
4	Start (reported on one line as ASCII comma delimited data) <ul style="list-style-type: none"> • 4a. Date • 4b. Time 	8 characters (each)

Calibration Report - Spreadsheet (continued)

Record Number	Description	Form
5	Stop (reported on one line as ASCII comma delimited data) <ul style="list-style-type: none"> • 5a. Date • 5b. Time 	8 characters (each)
6	Temperature	1 floating point
7	Calibration standard size	1 floating point
8	Number of purges	1 integer
9	Equilibration rates	1 floating point
10	Chamber Insert: <ul style="list-style-type: none"> • 0 = None • 1 = 10 cm³ (100 cm³ unit) 1 cm³ (10 cm³ unit) 0.1 cm³ (1 cm³ unit) • 2 = 35 cm³ (100 cm³ unit) 3.5 cm³ (10 cm³ unit) 	1 integer
11	Average cell volume	1 floating point
12	Cell volume standard deviation	1 floating point
13	Average expansion volume	1 floating point
14	Expansion volume standard deviation	1 floating point
15	Number of runs	1 integer
16	Carriage return / Line feed	
17	Carriage return / Line feed	
18	Carriage return / Line feed	
19	Run number and pressure (reported on one line as ASCII comma delimited data)	
19a	Run number	1 integer
19b	P1	1 floating point
19c	P2	1 floating point
19d	P1*	1 floating point
19e	P2*	1 floating point

Calibration Report - Spreadsheet (continued)

Record Number	Description	Form
19f	Include in average calculation <ul style="list-style-type: none">• 0 = Excluded• 1 = Included	1 integer
19g	Cell volume	1 floating point
19h	Cell volume deviation	1 floating point
19i	Expansion volume	1 floating point
19j	Expansion volume deviation	1 floating point

E RS-232 PIN ASSIGNMENT

The AccuPyc is a standard DTE device. The RS-232 port can be used to connect an analytical balance for transfer of sample weight, or for transmitting data to a computer. The receiving device must be configured to interface with the RS-232 pin assignments. Any signals that are not listed in the *RS-232 Pin Assignment* table are ignored.

RS-232 Pin Assignments

Pins	Signal	Description	Data Direction
2	RXD	Receive Data	Into AccuPyc
3	TXD	Transmit Data	From AccuPyc
4	DTR	Data Terminal Ready	From AccuPyc
5	GND	Ground	N/A
6	DSR	Data Set Ready	Into AccuPyc

The AccuPyc uses the DTR and DSR signals for hardware flow control. Ensure that the serial device provides these signals. For example, if attaching to a computer (also a DTE device), use a null modem cable which includes the designated signals. If transmission problems occur, ensure that the signals are set up properly. If the signals are correctly configured, contact the receiving device manufacturer for assistance.

Blank Page

F TEMPERATURE CONTROLLED ACCUPYC

A temperature controlled AccuPyc must be connected to a circulating bath (not provided by Micromeritics). Refer to the manufacturer operator manual for circulating bath operating instructions.

ATTACH A CIRCULATING BATH

The rear panel of the temperature controlled AccuPyc contains connections for a circulating bath. Provided in the accessory kit are two (2) hose fittings and a four (4) foot length of tubing.

1. Power off the controlling unit.
2. Remove the plugs from the **In** port and the **Out** port.

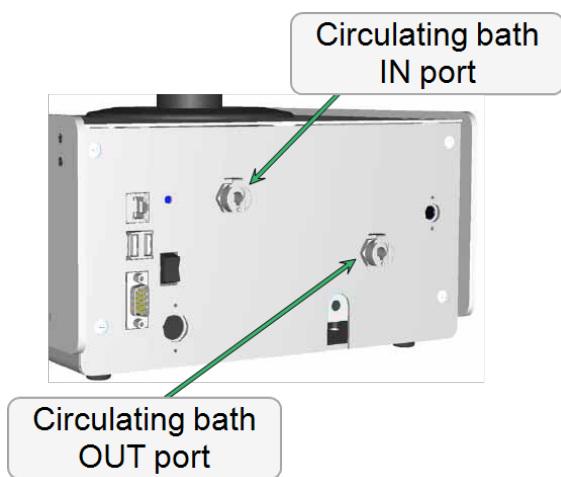

3. Insert the provided hose fittings into each connector.
4. Cut the piece of 4 ft. tubing into two equal pieces of 2 feet each.
5. Install the tubing on the **In** and **Out** connectors.
6. Install the other end of the **Out** tubing to the **Inlet** connection of the bath circulator.
7. Install the other end of the **In** tubing to the **Outlet** connection of the bath circulator.
8. Set the temperature using the appropriate controls on the bath circulator.

ADD ANALYSIS MODULES TO A TEMPERATURE CONTROLLED MODULE



If using the Windows version of the AccuPyc II, exit the application before powering off the analyzer.

1. Power OFF the controlling unit.

2. Connect the circulating bath. See ["Attach a Circulating Bath" on page J - 5](#).
3. Connect one end of the module connector cable (provided in the analysis module accessories kit) to the connector labeled **Module Connection** on the rear panel of the control module.
4. Connect the other end of the module connector cable to the lower connector labeled **Module Connector** on the rear panel of the analysis module.

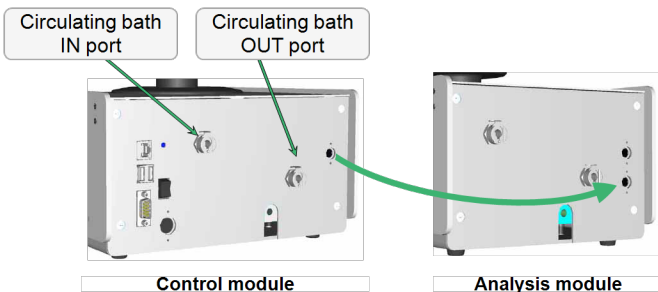

5. Power ON the analyzer. If using the Windows version of the AccuPyc II, start the application .
6. Calibrate the analysis module using the calibration kit shipped with the system. See ["Calibration" on page 10 - 1](#).

G MULTIVOLUME INSERT OPTION

The MultiVolume Insert option provides analysis of samples using smaller-sized sample chambers.

Equipment	Description
AccuPyc 1 cm ³	Includes a 0.1 cm ³ insert/sample cup combination.
AccuPyc 10 cm ³	Includes 1 and 3.5 cm ³ inserts with corresponding sample cups and appropriate calibration standards. Fritted filter lids are included for both inserts.
AccuPyc 100 cm ³	Includes 10 and 35 cm ³ inserts with corresponding sample cups and appropriate calibration standards. A fritted filter lid, which prevents the escape of sample particles under rapid gas flow, is included for the 10 cm ³ insert.
AccuPyc 2000 cm ³	Includes 650 and 1300 cm ³ cups, supporting inserts and calibration standards. A tool is also included to allow removal of the supporting inserts

See "[Parts and Accessories](#)" on page 13 - 1.

OPERATING PARAMETERS

To operate using inserts, access the *Chamber Insert* prompt to select the appropriate MultiVolume insert.

1. Press **Alt + 2** to access the *Setup* function.
2. Press **CHOICE** until *Report Options* is displayed, then press **ENTER**.
3. Continue pressing **ENTER** until the *Request Insert* prompt is displayed.
4. Press **CHOICE** until *Yes* is displayed, then press **ENTER**.

```
Unit[n]>   SN1234>   10 cm3
Report Options
Request insert?
Yes
```

5. Press **SAVE** to save the changes and return to the *Reload* prompt.

A *Chamber Insert* prompt will display during all normal operating procedures. For example, a *Chamber Insert* prompt will display when starting a calibration or analysis.

ABOUT INSERTS AND SAMPLE CUPS



Wear latex gloves when handling inserts and sample cups. Oils from skin may contaminate the surface and affect analysis results. See ["Handling System Components" on page J - 1](#).

An insert changes the size of the sample chamber and requires its own sample cup. All inserts are shipped with appropriate cups, with the exception of the 0.1 cm³ insert for the 1 cm³ unit. Because of its size, the sample cup for the 0.1 cm³ insert is built-in. The appearance of the inserts and cups varies.



- The fritted filter caps for the 1 cm³ and 3.5 cm³ inserts fit on top of the insert.
- The cap for the 10 cm³ insert (shown in image) fits on the sample cup.

This example shows a 10 cm³ cup and insert.

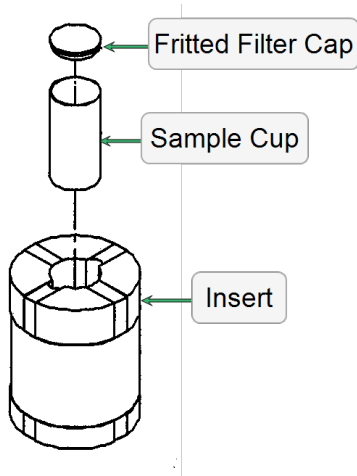

The inserts for the 2000 cm³ systems are installed and removed with a special tool.

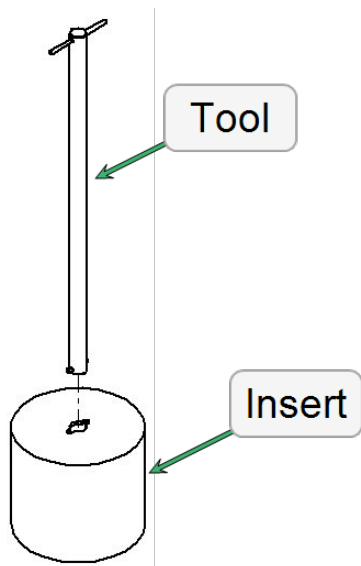

INSTALL AND REMOVE INSERTS AND SAMPLE CUPS

0.1 cm³ Insert

The MultiVolume kit contains a special tool required to install the 0.1 cm³ inserts. The sample cup is built into the 0.1 cm³ insert.

1 cm³ Insert

The MultiVolume kit contains a special tool required to install the 1 cm³ inserts.

Install the Insert

1. Remove the sample chamber cap and place on a clean work surface with the greased side facing upward.



Contamination from airborne particles can occur rapidly. The chamber cap should be left off the sample chamber for as little time as possible.

2. Place the insert into the sample chamber.
3. Use the handling tool to grasp the cup for placement in the insert. After placing the sample into the sample cup, insert the tip of the tool into the cup and press down firmly. The handling tool features an O-ring to grip the inside surface of the sample cup.

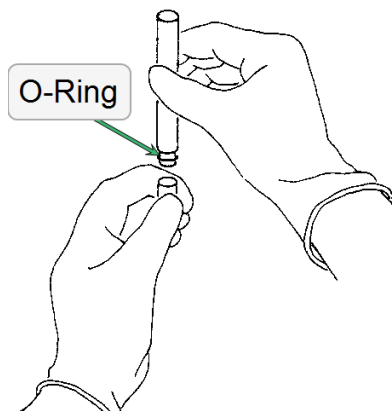

4. Place the cup into the insert, then tilt the tool to one side and remove it from the sample cup.

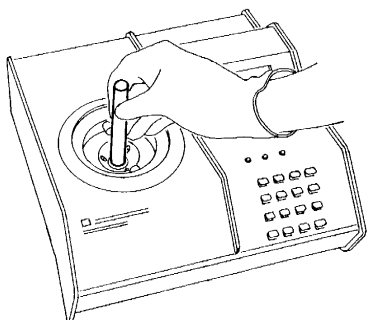

5. If using a fritted filter cap, place it onto the top of the insert.
6. Replace the sample chamber cap.

Remove the Insert

1. Remove the sample chamber cap and place on a clean work surface with the greased side facing upward.
2. Remove the fritted filter cap (if used).
3. Insert the handling tool into the sample cup until the sample cup is gripped by the O-ring.
4. Lift the sample cup out of the insert.
5. Pull the insert from the sample chamber.
6. Replace the sample chamber cap.

10, 3.5, and 35 cm³ Inserts

Remove the chamber cap and place the insert into the sample chamber. The insert should fit snugly in the chamber. Place the appropriate sample cup into the well of the insert.



Do not force the insert or cup into the openings. This may damage the instrument, insert, or sample cup.

Install the fritted filter cap (if used) before closing the sample chamber. A fritted filter cap is used to constrict gas flow and is included with some inserts. The fritted filter cap for the 10 cm³ insert fits on the top of the sample cup. The fritted filter caps for the 1 and 3.5 cm³ inserts fit on the top of the insert. Fritted filter caps are not available for the 0.1 and 35 cm³ inserts.

CALIBRATE INSERT

An insert must be calibrated and its operation verified. Appropriate calibration standards are included in the MultiVolume kits. For example, a 100 cm³ capacity AccuPyc with a 10 cm³ insert must be calibrated with the 10 cm³ insert, cup, and calibration standards.

0.1 CM³ INSERT

Because of the size of the 0.1 cm³ insert, its calibration is performed in a different manner from that of other inserts.



If the 1 cm³ pycnometer has not been calibrated recently, perform a calibration before calibrating the 0.1 cm³ insert.

1. Remove the sample chamber cap and place on a clean work surface with the greased side facing upward.
2. Place the insert into the sample chamber (the sample cup is built into the insert). Replace the chamber cap.
3. Press **Alt + 4** to access the *Analyze* function. Press **ENTER** until the *Chamber Insert* prompt is displayed. Ensure that *None* is displayed.
4. Press **ENTER** to display the *Analyze* prompt. Press **ENTER** to begin the calibration.
5. After the calibration is complete, the *Reload* prompt is displayed.
6. Press **CHOICE** until the average measured volume is displayed. Record this value.
7. Press **Alt + 2** to access *Setup*.
8. Press **CHOICE** until *Calibration Data* is displayed.
9. Press **ENTER** to display the *Chamber Insert* prompt.
10. Ensure that *None* is selected, then press **ENTER** to display the *Cell Volume* prompt.
11. Subtract the average volume of the 0.1 cm³ insert/cup (recorded in Step 6) from the cell volume displayed in the prompt. Record this value.
12. Press **ENTER** to display the *Expansion Volume* prompt.

13. Record the value displayed for the expansion volume, then press **ENTER** to return to the *Calibration Data* prompt.
14. Press **ENTER**. The *Chamber Insert* prompt is displayed.
15. Press **CHOICE** until 0.1 cm³ is displayed, then press **ENTER** to display the *Cell Volume* prompt. Enter the value recorded in Step 11.
16. Press **ENTER** to display the *Expansion Volume* prompt. Enter the value recorded in Step 12.
17. Press **SAVE** to save the information and return to the *Reload* prompt.

The pycnometer is now ready for analyses using the 0.1 cm³ insert/cup.

1, 10, 3.5, 35, 650, AND 1300 CM³ INSERTS

1. Remove the sample chamber cap and place on a clean work surface with the greased side facing upward.
2. Place the insert and sample cup into the sample chamber. Replace the chamber cap.
3. Calibrate the insert. See ["Calibration" on page 10 - 1](#).
4. See ["Verify Operation" on page 10 - 10](#).

H TEC MODULE

This AccuPyc system has been modified to provide temperature control from 15 to 36 °C. The system uses a thermoelectric control (TEC) system to heat or cool the AccuPyc. The temperature is controlled using a digital temperature controller and a separate power system from the AccuPyc.

It is suggested that the TEC system be installed first, to allow time for temperature to stabilize at the desired temperature, while the AccuPyc is being installed. See [".Add Analysis Module to Control Module" on page 11 - 1](#) and ["Set the TEC Temperature" on page J - 4](#).

SET THE TEC TEMPERATURE

1. Power on the TEC module. The power switch is located near the power inlet.

The digital display of the temperature controller will show a test message while it starts up. When the test message stops flashing, the current temperature displays. If the current temperature and a message such as *ErAt* displays, press the **P** (Program) key on the front panel of the controller. The *ErAt* message should stop and only the current temperature will display.

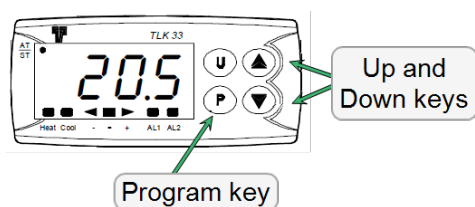

2. Press **P**. *SP 1* displays followed by the current setpoint (*SP 1*). Use the **Up** or **Down** key to set the temperature.
3. Press **P** to accept the temperature. The controller will now start heating or cooling to achieve the setpoint



The TEC module uses a fan to remove heat. The fan is located on the underside of the instrument. The fan pulls air into the instrument and the air is exhausted through ventilation slots on the rear panel. The exhaust slots must remain unobstructed.

Do not allow papers or other debris to be pulled across the fan as this will stop the necessary air flow. The TEC system will be unable to control temperature, and may become damaged.

OPERATE THE TEC MODULE

When the TEC controller shows the correct temperature, there may be a small difference between the temperature on the TEC unit and the AccuPyc display because two different sensors are being used. The AccuPyc sensor and electronics are calibrated together to compensate for any component differences between the sensor and the circuit board components. Micromeritics considers the AccuPyc temperature display to be a more accurate reflection of the sample temperature than the reading from the controller. The controller and the sensor used with the controller cannot be calibrated.

The TEC controller may be adjusted to compensate for the small difference. If the AccuPyc temperature is a little high, then reduce the setpoint of the TEC controller by the difference. Wait for stabilization. Readjustment may need to be repeated until the correct AccuPyc temperature is achieved.

The AccuPyc volume must be calibrated at the analysis temperature. Perform the volume calibration in the normal way until it is time to insert the reference volume (sphere or spheres). After installing the reference volume, wait at least 20 minutes to allow the volume to achieve the same temperature as the AccuPyc. Then continue as normal.

When it is necessary to perform AccuPyc tests at a different temperature, re-calibrate the system volume at the new temperature.

VOLUME CHANGE WITH TEMPERATURE FOR THE 10 CM³ ACCUPYC

The reference spheres supplied with the 10 cm³ AccuPyc are made from tungsten carbide. They were measured at 20 °C. The spheres will change volume with temperature. The change is very small and is shown in the following table. Every sphere is a slightly different size, and so the table provides the factor to be used if the value used during calibration needs to be adjusted. Multiply the volume provided with the reference spheres by the value in the right column.

Temperature (°C)	Typical Volume (cm³), two balls	Factor
15	6.37125	0.99991
20	6.37182	1.00000
25	6.37238	1.00009
30	6.37295	1.00018
35	6.37351	1.00027

For example, if the ball is 6.37182 cm³ at 20 °C but run at 50 °C, multiply the Volume × the Factor in the table.

$$6.37182 \times 1.00053 = 6.37520$$

VOLUME CHANGE WITH TEMPERATURE FOR THE 100 CM³ ACCUPYC

The stainless steel calibration standard (ball) supplied with the 100 cm³ AccuPyc is made from 440 grade stainless steel. It was measured at 20 °C. Its volume will be higher when heated above 20 °C. The following table uses the coefficient of thermal expansion of 440 grade stainless steel (0.0000101 m/m/degree C change) to provide the volume of the sphere at various temperatures.

Every ball is a slightly different size therefore the table provides the factor to be used if the value used during calibration needs to be adjusted. Multiply the volume provided with the reference sphere by the value in the right column.

Temperature (°C)	Typical Volume (cm ³)	Factor
15	51.089712	0.99995
20	51.092292	1.000000
25	51.094872	1.000051
30	51.097452	1.000101
35	51.100032	1.000152

For example, if the ball is 51.092292 cm³ at 20 °C but run at 50 °C, multiply the Volume × the Factor in the table.

$$51.092292 \times 1.000303 = 51.107773$$

ASPHALT DENSITY MEASUREMENT

Samples can be analyzed in disposable cups. Any difference in the mass of the cups used for calibration and analysis will be corrected for in the reported quantities. Performing an asphalt density measurement requires the AccuPyc II Asphalt software and disposable sample cups. Refer to ["Parts and Accessories" on page 13 - 1](#) for ordering information.

Steps 1-9 do not need to be repeated for subsequent analyses.

1. Set the instrument temperature and allow 12 hours for equilibration.
 2. Go to **Options > Options Presentation**. Select *Show Cup Properties*. Verify that a checkmark displays to the left.
 3. Label each disposable cup with a permanent marker and record its mass.
 4. Place a disposable cup in the 3.3 cm³ insert and position the insert in the sample chamber.
 5. Go to **Unit [n] > Calibration > Calibrate Volume**.
 - a. Enter the mass of the cup in the *Cup mass* field.
 - b. Enter the volume of the reference sphere in the *Volume of calibration standard* field.
 - c. Select the correct chamber insert.
 - d. Select *Measured*.
 - e. Click **Start**.
 6. Insert the reference sphere when prompted and resume the calibration.
 7. When the calibration is complete, remove the cup and reference sphere.
 8. Prepare a sample in a different disposable cup and place it in the sample chamber.
 9. Create a sample file for the analysis.
 10. Go to **Unit [n] > Sample Analysis** and select the sample file created in the previous step.
 11. Enter the mass of the cup in the *Cup mass* field.
 12. Select the chamber insert that was used for calibration.
 13. Click **Start**.
-

I MULTIGAS OPTION

The Multigas option enables the AccuPyc to use up to four different gases. The Multigas assembly consists of:

- Valve assembly and two retaining screws
- Gas entrance tubing for connection from the analyzer to the valve assembly
- Gas supply tubing for four gases

INSTALL THE MULTIGAS ASSEMBLY

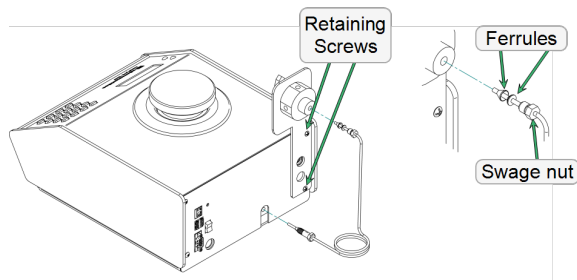

If a gas is attached to the gas inlet on the rear panel of the analyzer, close the gas cylinder valve and remove the inlet tubing from the analyzer before installing the multigas assembly. The gas can then be attached to one of the inlet valves on the assembly.

1. Remove the two retaining screws on the rear panel of the AccuPyc.
2. Position the valve assembly against the rear panel so that the retaining screw holes on the valve assembly align with those on the rear panel of the analyzer.
3. Attach the valve assembly to the rear panel using the two screws included in the multigas kit.
4. Carefully cut and remove the cable ties holding the gas entrance tubing in position and remove the ties.
5. Remove the protective caps from the ends of the gas entrance tubing, then remove the ferrules from the upper end of the tubing.
6. Remove the nut from the center port and slide it onto the end of the gas entrance tubing, then replace the front and rear ferrules.
7. Insert the tubing into the center port of the multigas assembly. Use the nut to secure the tubing to the assembly.
8. Insert the other end of the tubing into the gas inlet. Use the self contained swage nut to secure the tubing to the inlet.

CONNECT GASES

1. Connect one end of the gas supply tubing to the gas supply. See ["Instrument Components" on page 1 - 4.](#)
2. Insert the other end of the tubing into one of the valve inlets on the multigas assembly.
3. The faceplate of the valve assembly contains four sections; one for each gas inlet on the assembly. Write the name of the gas in the applicable section.

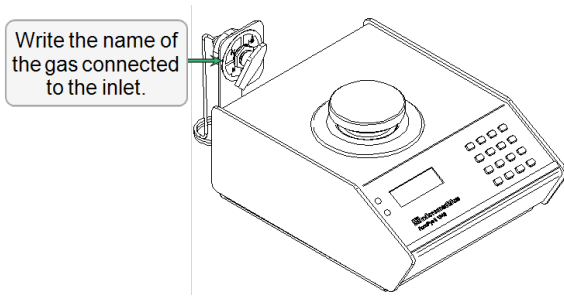

SELECT GASES

After installing the gases, use the knob to select the gas. Purge the gas lines when changing gases.

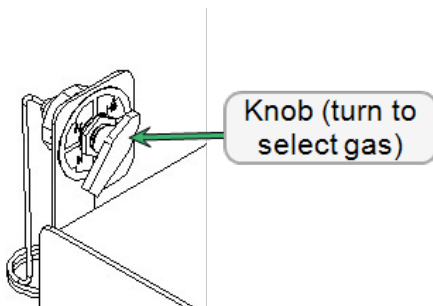

J INSTALLATION INSTRUCTIONS

These instructions assume that the shipping cartons have been opened and their contents checked and verified as instructed in the AccuPyc II Installation Checklist part number 134-42870-02.

HANDLING SYSTEM COMPONENTS

CALIBRATION STANDARD

- Wear latex or nitrile, powder-free gloves to prevent transfer of oil from hands.
- Do not drop the standard into the sample cup. Roll the standard into the cup to prevent damage.
- Always return the standards to the case. Standards are unit specific.

SAMPLE CHAMBER CAP

- Wear latex or nitrile, powder-free gloves to prevent transfer of oil from hands.
- Keep the cap on the sample chamber except when inserting or removing the sample cup .



When left uncapped, the sample chamber temperature may become unstable and / or water vapor will adsorb on the inner surface of the chamber. Either of these conditions can affect analysis results.

- Avoid laying the chamber cap on a work surface. Debris may collect on the greased surface of the O-ring which can also affect analysis results.
- When multiple analysis modules are connected, never interchange sample chamber caps. Caps are unit specific.

GAS REQUIREMENTS

The pycnometer uses helium or nitrogen (99.995% pure or better) to provide rapid, accurate analyses. The cylinder containing helium must be fitted with a gas regulator set for 19-23 psig (131-159 kPag). The pressure input to the pycnometer should never be greater than 25 psig (172 kPag). Excessive pressures waste gas due to a protection device contained in the pycnometer that vents the pycnometer to atmospheric pressure if pressure exceeds 35 psig (241 kPag).

This protection device is not installed on 2000 cm³ units.



Minimum recommended gas tank pressure is 200 psig (1379 kPag).

Other inert, dry gases can also be used and may be more applicable for some applications.

PYCNOMETER SET UP

PYCNOMETER CONFIGURATION

Single Module Configuration

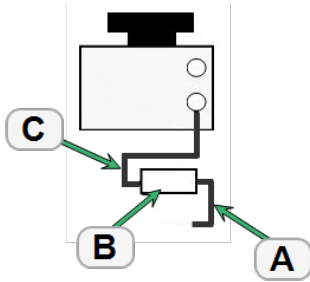

Control Module and Analysis Module Configuration

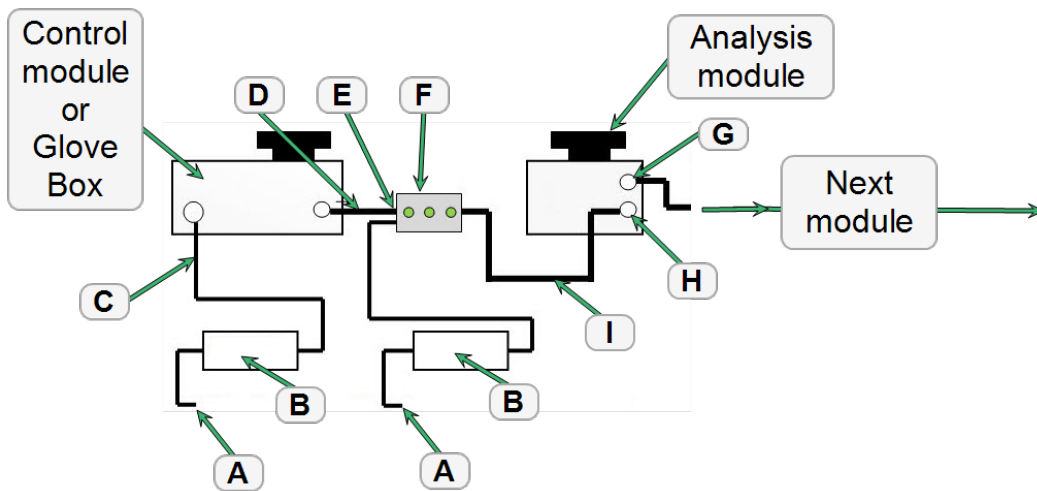

TEC Module Configuration

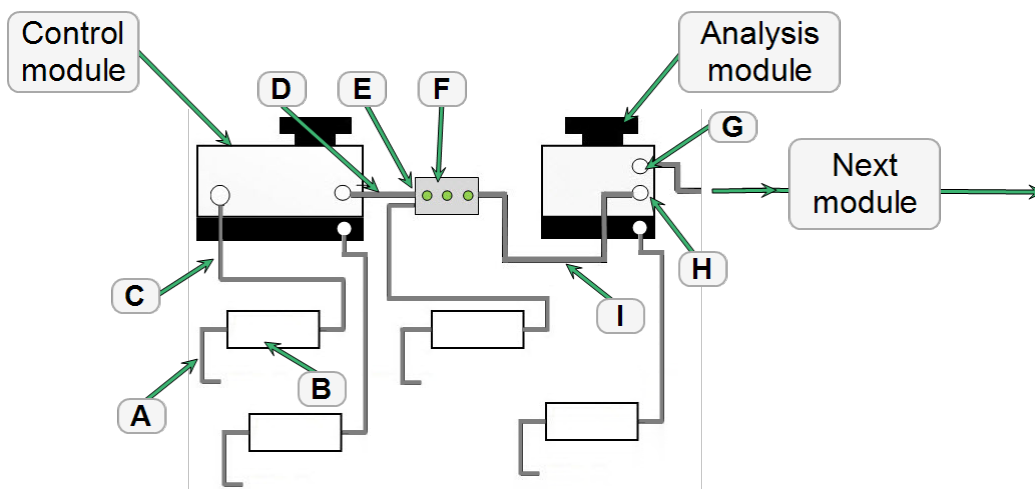

Diagram Components

Component	Description
A	Separate power cord for external power supply. Connect cable to wall outlet.
B	External power supply
C	Hardwired 8-pin mini-DIN power cable for external power supply.
D	8 pin mini DIN cable.
E	Power adapter DIN port.
F	Power adapter.
G	Module Connection - 8-pin mini-DIN OUT port to connect next analysis module.
H	Module Connection - 8-pin mini-DIN IN port to connect the control module or previously connected analysis module (not shown).
I	Hardwired power mini-DIN cable for power adapter.

Set Up Procedure

1. Unpack and inventory all boxed parts. Contact your Micromeritics Service Representative if parts are missing or broken.
2. Place module(s) on work surface.
3. Connect separate power cable(s) to external power supply(s).
4. Connect external power supply(s) to power outlet on the module(s).
5. Connect power cable to wall outlet.
6. Toggle the module power switch to the ON position.

7. Check the power indicator on the front panel of the analyzer. The indicator will blink green to indicate that power is applied to the analyzer. Once the application is running, the indicator will stop blinking and remain illuminated.
8. On the keypad, press **Alt + CHOICE + 2**. *Unit [n]* appears in the upper left corner of the display.

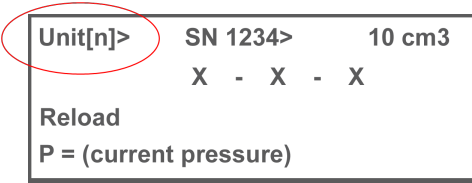

9. Adjust the display brightness control using the **Brightness Control** button on the rear of the analyzer.

SET THE TEC TEMPERATURE

1. Power on the TEC module. The power switch is located near the power inlet.

The digital display of the temperature controller will show a test message while it starts up. When the test message stops flashing, the current temperature displays. If the current temperature and a message such as *ErAt* displays, press the **P** (Program) key on the front panel of the controller. The *ErAt* message should stop and only the current temperature will display.

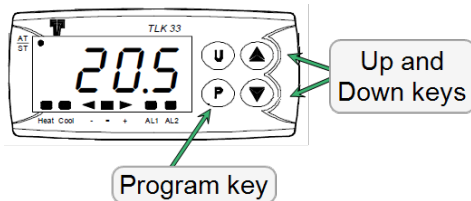

2. Press **P**. *SP I* displays followed by the current setpoint (*SP I*). Use the **Up** or **Down** key to set the temperature.
3. Press **P** to accept the temperature. The controller will now start heating or cooling to achieve the setpoint



The TEC module uses a fan to remove heat. The fan is located on the underside of the instrument. The fan pulls air into the instrument and the air is exhausted through ventilation slots on the rear panel. The exhaust slots must remain unobstructed.

Do not allow papers or other debris to be pulled across the fan as this will stop the necessary air flow. The TEC system will be unable to control temperature, and may become damaged.

TEMPERATURE CONTROLLED MODULE HARDWARE SETUP

Setup a Single Temperature Controlled Module

See ["Pycnometer Configuration" on page J - 2](#) for setup instructions. When complete, connect the circulating bath.

Attach a Circulating Bath

The rear panel of the temperature controlled AccuPyc contains connections for a circulating bath. Provided in the accessory kit are two (2) hose fittings and a four (4) foot length of tubing.

1. Power off the controlling unit.
2. Remove the plugs from the **In** port and the **Out** port.

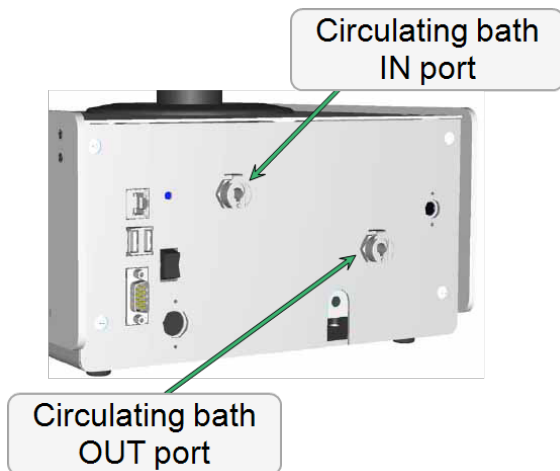

3. Insert the provided hose fittings into each connector.
4. Cut the piece of 4 ft. tubing into two equal pieces of 2 feet each.
5. Install the tubing on the **In** and **Out** connectors.
6. Install the other end of the **Out** tubing to the **Inlet** connection of the bath circulator.
7. Install the other end of the **In** tubing to the **Outlet** connection of the bath circulator.
8. Set the temperature using the appropriate controls on the bath circulator.

CHAMBER CAP O-RING

See ["Grease the Chamber Cap O-Ring" on page 12 - 4.](#)

CONNECT KEYBOARD

An optional USB keyboard can be connected to a USB port on the rear panel of the analysis module. The keyboard is not provided by Micromeritics.

CONNECT AN ANALYTICAL BALANCE

An analytical balance can be connected to a serial port on the computer and used to transfer the sample's mass via a third-party software directly to the AccuPyc II application. Refer to the balance manufacturer's operator's manual for transmission instructions.

Connect the analytical balance to the RS-232 port on the rear panel of the analyzer.

To configure the Analytical Balance, see ["Configure an Analytical Balance" on page J - 20](#).

GAS CONNECTION



These instructions are for connecting inert gases only. Follow the safety procedures used by your laboratory for connecting hazardous gases.



Review ["Gas Requirements" on page J - 1](#) prior to installing gas.

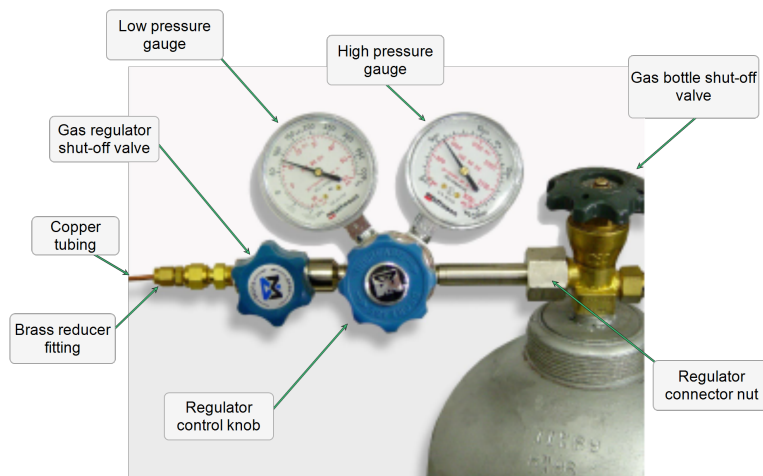

1. Attach an appropriate regulator to the gas cylinder or gas line, then tighten with a wrench. Leave the gas bottle shut-off valve closed until instructed otherwise.
2. Attach the gas inlet line to the regulator, reducer fitting, or regulator expansion:



It is important to use the inlet tubing supplied with the analyzer. Gas lines made of materials other than copper or stainless steel can cause operational problems as well as inaccurate data.

If Regulator has...	Then...
1/4 in. outlet	Attach the reducer fitting to the outlet of the regulator shut-off / isolation valve
	Tighten the nut finger-tight, then 1-1/4 turns with a wrench.
	Continue with the steps given for the 1/8 in. outlet
1/8 in. outlet	Insert the gas tubing into the fitting.
	Ensure the tubing is seated fully inside the fitting.
	Tighten the nut finger-tight
	While holding the fitting body steady, tighten the nut with a wrench 3/4 turn.



Do not overtighten the fittings. Doing so can collapse the brass fitting and cause a leak.

3. Purge the regulator and inlet tubing to prevent contamination of the analysis gas.
 - a. Turn the regular shut-off valve clockwise to close.
 - b. Turn the pressure regulator control knob counter-clockwise to open.
 - c. Slowly turn the gas cylinder shut-off valve counter-clockwise to open, then quickly close it.
 - d. Observe the high-pressure gauge.

If the pressure decreases, tighten the nut connecting the regulator to the gas cylinder. If the pressure is stable, proceed to the next step.



Ensure the gas supply equipment is adequately vented before performing the next step.

- e. Turn the pressure regulator control knob clockwise until the low-pressure gauge indicates 19.500 psig (134.445 kPag).
- f. Turn the regulator shut-off valve counter-clockwise to open.
- g. Turn the gas cylinder shut-off valve counter-clockwise to open. Flow gas for 10 to 30 seconds, then close the valve.
- h. Turn the gas regulator shut-off valve clockwise to close

4. Attach the other end of the copper tubing to the gas inlet on the rear panel of the pycnometer. Remove the inlet plug that shipped with the pycnometer.

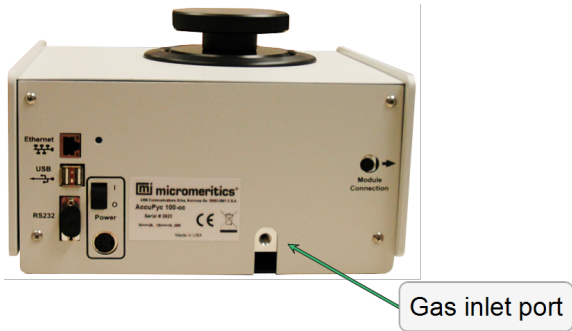

5. Turn the nut on the tubing clockwise until it is finger-tight. Then use a 7/16 in.(1 mm) wrench to tighten the nut an additional 1/4 turn.
6. Open the gas cylinder and regulator shut-off valves.
7. Turn the regulator control knob until the low pressure gauge indicates 21.5 psig (148 kPag).

CONNECT THE ANALYZER TO THE COMPUTER

If using the analyzer with the keypad or keyboard only, skip this section.

An Ethernet switch is required if connecting a different type of analyzer to the same computer as the AccuPyc. If configuring multiple AccuPyc modules, they are connected together with only the Control Module connected to the Ethernet switch. See ["Connect an Ethernet Switch" below](#).

CONNECT AN ETHERNET SWITCH

An Ethernet switch is required to connect one or more analyzers and one computer.

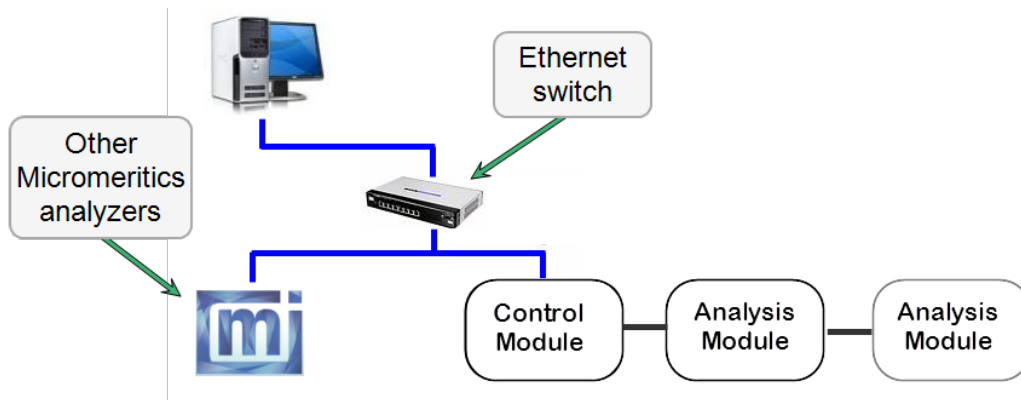

BRIGHTNESS CONTROL



To adjust the display brightness:

1. Insert a small flat head screwdriver into the opening.
2. Rotate the screwdriver until it engages in the slot, then turn clockwise to darken and counterclockwise to lighten.

CONFIGURE THE PYCNOMETER

If using the keypad option, see ["Configure the Pycnometer using the Keypad" below](#) and skip the section on ["Software Installation" on page J - 15](#).

When using the software application, the display window on the pycnometer is disabled.

CONFIGURE THE PYCNOMETER USING THE KEYPAD



If using the keypad to control analyses, follow these instructions for configuring the module. If using the Windows application, skip this section.

Complete the installation process by configuring the module:

- Unit type. See ["Unit Types" on page J - 13](#).
- System setup (date / time / language). See ["System Setup" below](#).
- Calibrate. See ["Calibrate Volume" on page 10 - 15](#).
- Reports. See ["Setup Reports" on page 2 - 9](#).
- Transmit parameters. See ["Transmit" on page 2 - 6](#).
- Printer setup. See ["Printer Setup" on the facing page](#).

System Setup

Press **Alt + 2** to access the set-up function.

Display	Description
<pre>Unit[n]> SN1234> 10 cm3 Setup Type? Analysis Parameters</pre>	<p>Setup. Choose or enter parameters for analysis, calibration, reporting, and data transmission.</p> <p>Choices: <i>Analysis Parameters, Report Options, Calibration Data, Communications, Unit Types</i></p> <p>Press CHOICE to display the set up type, then press ENTER.</p> <p>The parameters for each set up type are stored and used to control the pycnometer until new ones are specified.</p>

At the completion of each set up, the display returns to the *Setup type?* prompt.

- Press **SAVE** to save the information and return to the *Reload* prompt.
- Choose another set up type. Do not press **SAVE** until all parameters have been entered. The display will return to the *Reload* prompt.
- Press **Alt + CLEAR** to discard the information entered and return to the *Reload* prompt.

Printer Setup

Printers are connected to the AccuPyc II via a USB port. See ["Specifications" on page 1 - 10](#) for a list of supported printers. Using the keypad:

1. On the display, select *Setup > Report Options*.
2. Press **ENTER** until the *Printer?* prompt is displayed.
3. Press **CHOICE** until the appropriate printer driver is displayed.

Communications



Use these instructions for keypad installations only. If a computer will be attached to the module, skip this section. All setup functions will be done in the analysis software application.

Communications enables specification of communications criteria, such as baud rate, parity, etc.

Display Text	Description
Setup Type? Communications	Press CHOICE until Communications is displayed.
Communications IP Address? [choice]	<p>Enables selection of the manner in which the IP address is assigned. With an IP address, analysis results can be access via a web browser. Typically, after an analysis (or calibration) is started, results from the previous operation cannot be reviewed. However, results from five analyses are stored in the controller. A web browser enables review of these results. An IP address must exist for this operation. An IP address can be detected and assigned automatically, or one can be specified.</p> <p>Ensure the Ethernet cable is plugged into the Ethernet port on the analyzer and to the network. Choose <i>DHCP</i> to have an IP address assigned automatically, or <i>Specify</i> to specify an address. Press CHOICE until the option is displayed.</p> <p>If using <i>DHCP</i>, an IP Address should be assigned within a minute.</p>

Display Text	Description
Communications Requesting Address * [ENTER] to continue	<p>Displays the first-time selection of <i>DHCP</i>.</p> <p>Press ENTER. The system automatically attempts to assign an IP address. If the system is able to determine an address, the assigned address is displayed.</p> <div data-bbox="553 457 1029 636" style="border: 1px solid black; padding: 5px;"> <pre>Unit[n]> SN1234> 10 cm3 Communications Assigned Address: (assigned address)</pre> </div>
Communications Requesting Address [ESCAPE] to cancel	<p>If an address cannot be determined, this prompt is displayed:</p> <div data-bbox="553 726 1029 905" style="border: 1px solid black; padding: 5px;"> <pre>Unit[n]> SN1234> 10 cm3 Communications Requesting Address [ESCAPE] to cancel</pre> </div> <p>Press Alt + CLEAR to cancel the operation and return to the <i>Reload</i> prompt. Contact your IT department, or choose the <i>Specify</i> option and enter the appropriate information.</p>
Communications IP Address * (user entered)	<p>Displays when the <i>Specify</i> option is selected. Enables entry of an appropriate IP address. This is a numerical field in the following format: <i>nnn.nnn.nnn.nnn</i>. Enter the address.</p>
Communications Subnet Mask * (user entered)	<p>Enables entry of the subnet mask number. Enter the subnet mask number.</p>
Communications Gateway * (user entered)	<p>The Gateway address is used for communicating outside the local network. The Gateway address is often the same as the IP address, with a “1” after the last dot instead of the last three characters (<i>nnn.nnn.nnn.1</i>). Contact your IT department with any questions.</p>
Communications E-mail Address:	<p>When connected to a network, analysis or calibration results can be e-mailed automatically upon their completion. This prompt enables entry of the e-mail address where results are to be sent.</p> <p>If not using <i>DHCP</i> and the e-mail address is outside the local network, specify a gateway address (see previous prompt). A keyboard is required to type in the e-mail address.</p>
Communications E-mail Server:	<p>Enables entry of the numerical address of the SMTP server. If this address is unknown, contact your IT department.</p>

Display Text	Description
IT may need to configure the server to accept email from the AccuPyc. The following information may be required: <ul style="list-style-type: none"> • IP address for the AccuPyc • Sender line: Micromeritics-1340 	IT may need to configure the server to accept e-mail from the AccuPyc. The following information may be required: <ul style="list-style-type: none"> • IP address for the AccuPyc • Sender line: Micromeritics-1340
Communications Baud Rate?	Press CHOICE to select proper baud rate.
Communications Data Bits?	Press CHOICE to select 8 or 7 .
Communications Stop Bits?	Press CHOICE to select 1 or 2 .
Communications Parity?	Press CHOICE until the required option (<i>None</i> , <i>Even</i> , or <i>Odd</i>) is displayed.
Communications Xon / Xoff Protocol?	Transmits data through the <i>Xon/Xoff protocol</i> . Press CHOICE to select <i>Disabled</i> or <i>Enabled</i> .
* Does not display for DHCP.	

Unit Types

If not using the analyzer software, these keypad prompts enable selection or entry of:

- units of measurement
- operating language
- current date and time

Display Text	Description
Set-up Type? Unit Types	Press CHOICE until <i>Unit Types</i> is displayed, then press ENTER .
Unit Types Pressure units?	Enables selection of unit type for reports. Press CHOICE to select the desired unit. <p>Options are:</p> <ul style="list-style-type: none"> • psig (pounds per square inch gauge) • kPag (kilopascal gauge)

Display Text	Description
Unit Types Language?	Enables selection of operating language. Pressing SAVE is not required. Error messages that may be in the message queue will remain in English (or the current selected language). Error messages that occur after selecting the language will display in that language. Keypad overlays containing translations for the alternate functions are available for each language. Choose the language.
Unit Types Date (DD/MM/YY)?	The date is entered in a two digit format for the day, month, and year. For example; to set the date for September 1, 2014, enter 01/09/14 (day/month/year). Use the . (decimal) key to enter a slash (/).
Unit Types Time (HH:MM:SS)?	The time (in 24 hour format) at which an analysis begins and ends is shown on all reports. The time shown on the display may not match the current time. The time is entered in a two digit format for the hour, minutes, and seconds. For example; to set the time to 1:05 pm, enter 13:05:00 (hour:minutes:seconds). Use the . (decimal) key to enter a colon (:).

Setup Date, Time , and Language

1. On the keypad, press **Alt + 2** to enter *Setup* mode.
2. Press **Choice** until *Date* displays, then press **Enter** and enter the current date.
3. Press **Choice** until *Time* displays, then press **Enter** and enter the current time.
4. Press **Choice** until *Language* displays, then press **Enter** and select the correct language.

Calibration

See ["Calibrate Volume" on page 10 - 15.](#)

SOFTWARE INSTALLATION



If installing multiple analyzers, connect the Ethernet switch to the configured port on the computer, connect the analyzers to the Ethernet switch, then turn the analyzers on.



The application should not be installed on a network drive with shared access. Multiple users cannot operate the application at the same time.



If the computer is to be connected to a network, a second Ethernet port on the computer must be used for that purpose.

These prerequisites must be completed prior to installing the software:

- Configure an Ethernet port on the computer to communicate with the analyzer. The IP address must be 192.168.77.100. Reference the computer operator manual for instructions on changing the IP address.
- Attach the analyzer to the computer's configured Ethernet port. Use an Ethernet switch if multiple analyzers will be attached.
 1. Insert the installation CD into the CD-ROM drive. The program automatically starts the installation. If the installation does not immediately start, navigate to the CD-Rom drive, then locate and double click the *setup.exe* file.
 2. On the *Ethernet Introduction* window, verify that all prerequisites have been met.
 - a. If not, click **Cancel** and complete the steps, then restart the installation program. Do not proceed with installation until these tasks have been completed.
 - b. If the prerequisites have been met, click **OK**.

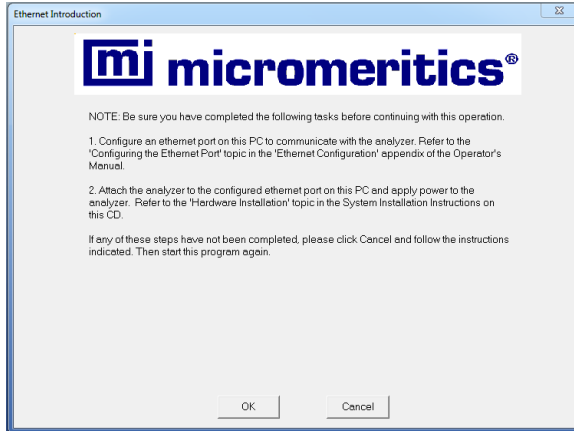

3. On the *New Installation* window, verify that sufficient disk space is available to continue the installation. If not, click **Exit** and free up the minimum required disk space. If the disk space is OK, click **Next** to accept the default installation directory, or click **Browse** to change the installation location.
 - a. To add a shortcut to the desktop, select the *Add the application icon to the Desktop....* checkbox.
 - b. To allow all computer users access to the software application, select *Install this application for All Users.all users of the computer.*
 - c. Click **Next**.

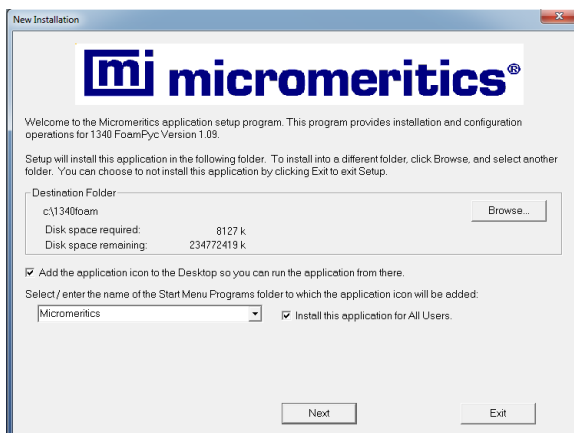

4. On the *Analyzer Configuration* window, select *1* for the number of analyzers to be installed and enter the analyzer serial number in the text box.

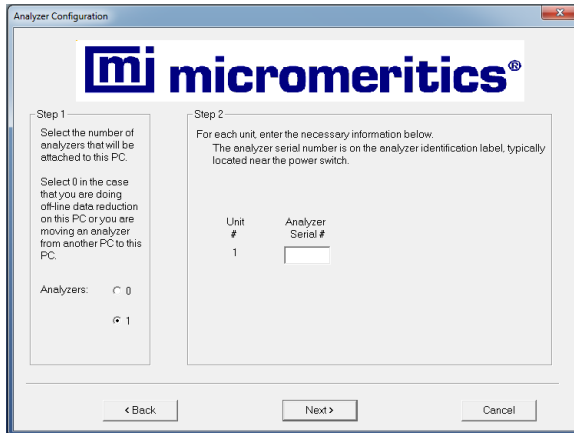

10. On the *Ethernet Ports* window, select one option from the following table:

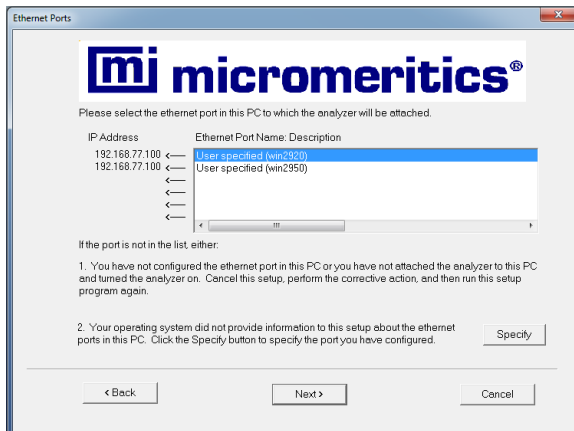

If...	Then...
the configured port is listed	Select the port, then click Next .

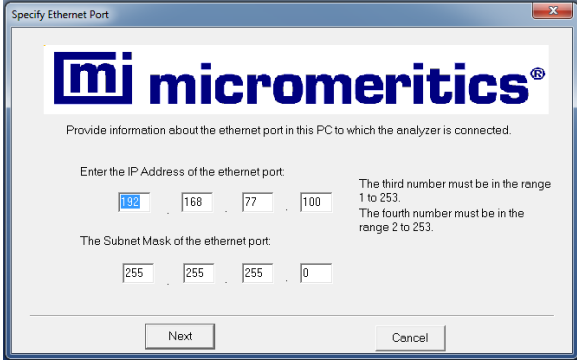
If...	Then...
<p>the configured port is not listed</p>	<p>Click Specify and enter the remaining portion of the IP Address, then click Next.</p> <hr/> <div style="display: flex; align-items: center;"> <p>The IP Address must be 192.168.77.100</p> </div> <hr/> 

- If prompted to configure a balance, select either *0* or *1*. The balance should be connectd to Com Port 1. The default parameters should be OK. If not prompted for a balance, skip this step.

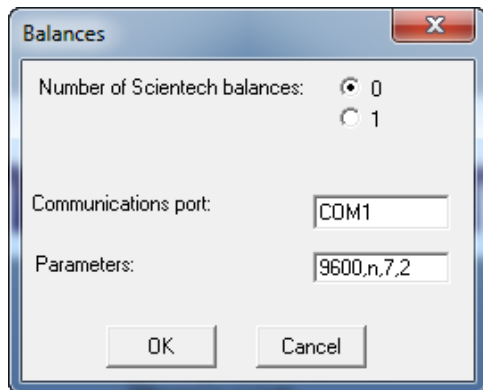

- On the *Installation Complete* window, click **Finish**.

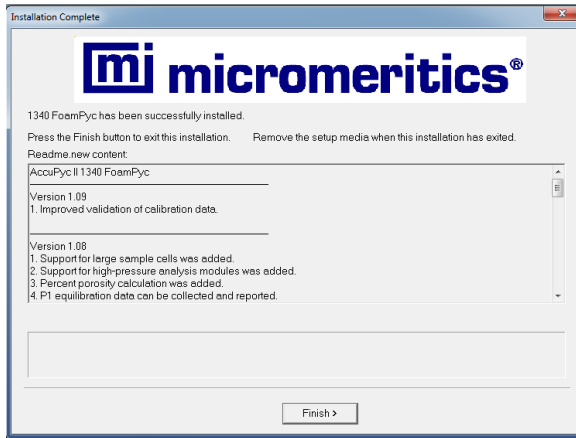

START THE APPLICATION

To start the application, click the application shortcut on the desktop or select the application from the Windows program list.

SPECIFY UNIT SELECTIONS

Options > Units

Use to specify how data should appear on the application windows and reports.

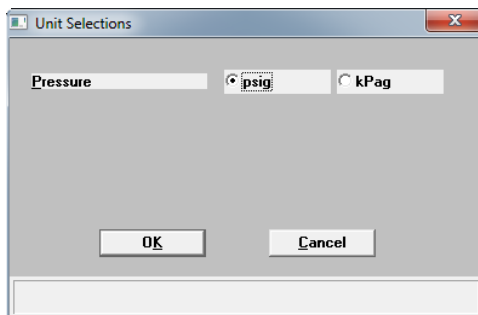

CONFIGURE AN ANALYTICAL BALANCE

Options > Configure Balance



Used to connect and set up an RS-232 balance to the analyzer. See ["Connect an Analytical Balance" on page J - 6.](#)

The analytical balance tested by Micromeritics is Scientec® model #ZSA120. See ["Parts and Accessories" on page 13 - 1.](#)

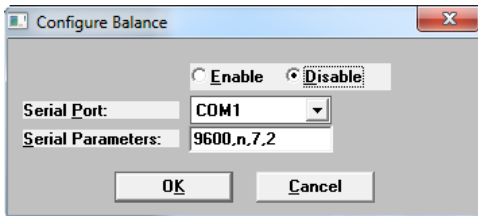

Configure Balance Fields and Buttons Table

Field or Button	Description
Enable / Disable	Select to enable or disable the attached balance.
Serial Parameter	Used to set the baud rate, parity, data bits, and stop bits. This field should not require modification from the default values.
Serial Port	Select which serial port is used to connect the balance to the analyzer.

REINSTALL OR MODIFY THE SOFTWARE



If the computer is to be connected to a network, a second Ethernet port on the computer must be used for that purpose.

The *Setup* program is located on the installation CD. After initial software installation, if changes need to be made to the analyzer setup, reinsert the *Setup* CD and follow the prompts.

- Reinstall the software version [*n*]
- Add an analyzer
- Move an analyzer
- Remove an analyzer
- Change analyzer setup
- Reinstall calibration files for an analyzer
- Uninstall
- Reset security to default

To access the *Setup* program:

1. Insert the *Setup* CD into the CD drive.
2. Locate and double click the *Setup.EXE* file.



If the IP address needs to be changed on the computer connected to the analyzer, refer to the computer's operating system manual or the internet for instructions. The IP address for the computer and the IP address specified in the setup program must match. The IP address must be 192.168.77.100.

UNINSTALL THE SOFTWARE

When the software is uninstalled, only the files required to run the application are removed. Parameter files, sample files, reports, calibration files, and data files are not removed.

1. Insert the *Setup* CD into the CD drive.
2. Select the *Uninstall* option.
3. Follow the prompts.

INDEX

0

0.1 cm³ Insert
 calibrate *G - 5*

1

1, 10, 3.5, 35, 650, and 1300 cm³ Inserts
 calibrate *G - 6*

A

About this manual *iii*
 AccuPyc
 about *1 - 1*
 Advanced presentation option
 create sample files *4 - 2*
 Analysis
 Cancel *2 - 5*
 Parameter Files *2 - 7*
 Perform *6 - 1*
 QuickStart *6 - 6*
 review *6 - 9*
 sequence *6 - 8*
 start *6 - 3*
 start, using keypad *6 - 4*
 start, using software *6 - 3*
 Analysis conditions
 create parameter file *5 - 2*
 defined *5 - 2*
 FoamPyc Application *5 - 4*
 Analysis Module
 Add to Temperature Controlled Unit *F - 1*
 Analytical Balance
 connect *J - 6*
 Analyzer
 connect to computer *J - 9*
 power on and off *1 - 12*
 schematic *3 - 9*
 show status *3 - 10*
 Analyzer Status *3 - 8*
 Analyzing, file status *3 - 6*

Application
 start *J - 19*
 Asphalt Density Application *1 - 2*
 Asphalt Density Calculations *B - 11*
 Asphalt Density Measurement, TEC
 Modules *H - 4*
 Axis Cross-hair *7 - 17*

B

Balance
 configure *11 - 3, J - 20*
 connect *J - 6*
 Brightness Control *J - 9*

C

Calculations *B - 1*
 Active Area *B - 5*
 Analysis *B - 1*
 Asphalt Density *B - 11*
 Calibration *B - 4*
 for FoamPyc Methods *B - 2*
 Geometric Volume *B - 5*
 Percent Porosity *B - 10*
 Resin Volume *B - 10*
 Run Precision *B - 6*
 SPC Report Variables *B - 8*
 Total Pore Volume *B - 6*
 Total Solids Concentration *B - 7*
 Volume Offset *B - 4*
 Volume Scale *B - 4*
 Calibrate
 insert *G - 5*
 Insert
 0.1cm³ *G - 5*
 1, 10, 3.5, 35, 650, and 1300 cm³
 Inserts *G - 6*
 temperature offset *10 - 2*
 using the keypad *10 - 14*
 using the software *10 - 1*
 volume *10 - 15*
 volume scale *10 - 6*
 zero cell volume *10 - 2*
 zero pressure *10 - 4*

- Calibrate Function, keypad *10 - 14*
 - Calibration *10 - 1*
 - Calculations *B - 4*
 - copy data *10 - 20*
 - data, keypad *10 - 14*
 - load data *10 - 20*
 - load from file *10 - 12*
 - report *10 - 1*
 - reset pressure *10 - 5, 10 - 16*
 - review *10 - 17*
 - save to file *10 - 13*
 - Temperature *10 - 19*
 - verify operation *10 - 10*
 - Zero the chamber volume (using the keypad)
10 - 19
 - Zero the pressure transducer (using the keypad)
10 - 19
 - Cell leaks
 - check for *12 - 6*
 - check using software *12 - 6*
 - check using the keypad *12 - 8*
 - Chamber Cap O-Ring *12 - 4*
 - Circulating bath, attach *F - 1, J - 5*
 - Collected Data *5 - 7*
 - Combined Report
 - report example *7 - 24*
 - report options *8 - 1*
 - Common Fields and Buttons *3 - 2*
 - Complete, file status *3 - 6*
 - Components
 - handling *J - 1*
 - instrument *1 - 4*
 - Computer
 - connect to analyzer *J - 9*
 - Configuration
 - AccuPyc II *1 - 8*
 - Contact Us *ii*
 - Control chart, report *7 - 5*
- D**
- Data
 - review *2 - 11*
 - view results *2 - 13*
 - Data Entry, Keypad *2 - 1*
- Density and Volume Table
 - report options *8 - 1*
 - Density vs Cycle Number
 - report options *8 - 2*
 - Density vs Time
 - report options *8 - 3*
 - Diagnostics, using Software *9 - 1*
 - Display *2 - 1*
 - Dust filter, clean *12 - 9*
- E**
- Equilibration
 - Report Example *7 - 29*
 - Equilibration Report
 - report options *8 - 4*
 - Equipment Options *1 - 7*
 - Error messages
 - Keypad *A - 19*
 - Windows *A - 1*
 - Ethernet Switch, connect *J - 9*
 - Expansion Chamber
 - check for leaks *12 - 6*
 - check for leaks using software *12 - 6*
 - check for leaks using the keypad *12 - 8*
- F**
- Features and shortcuts
 - graphs *7 - 13*
 - tabular report *7 - 19*
 - Files
 - default locations *3 - 6*
 - description *3 - 6*
 - extensions defined *3 - 6*
 - status *3 - 6*
 - FoamPyc Option *1 - 3*
- G**
- Gas Connection *J - 6*
 - Gas Requirements *J - 1*
 - Gas Supply
 - Connect Gases *I - 2*
 - Select Gases *I - 2*

Gases
 connect a replacement gas cylinder *12 - 13*
 disconnect the depleted gas cylinder *12 - 12*
 guidelines for connecting *12 - 11*
 replace a gas cylinder *12 - 12*

Glove Box *1 - 8*

Graph
 features and shortcuts *7 - 13*
 generate overlays *7 - 20*
 Report Example *7 - 27*
 zoom feature *7 - 18*

Graph Grid Lines *7 - 18*

H

Handling System Components *J - 1*

Hardware components, install *11 - 1*

I

Insert

 1 cm³
 install *G - 3*
 remove *G - 4*

Inserts *G - 2*

 0.1 cm³ *G - 3*
 1 cm³ *G - 3*
 10, 3.5, and 35 cm³ *G - 4*
 install and remove *G - 3*
 Operating Parameters *G - 1*

Install

 Hardware components *11 - 1*
 Software Upgrade *3 - 14*

Installation

 software *J - 15*

Installation Instructions *J - 1*

Instrument components *1 - 4*

Instrument log, show *3 - 8*

K

Keyboard, connect *J - 6*

Keypad

 about *2 - 2*
 calibrate using *10 - 14*

Reports, setup *2 - 9*

L

Leaks, check for *12 - 6*

Leaks, check using software *12 - 6*

Leaks, check using the keypad *12 - 8*

List files *3 - 11*

M

Maintenance

 guidelines for connecting *12 - 11*

 replace gas cylinder *12 - 12*

Manual mode *2 - 5*

Manual, about this *iii*

Material Parameters *4 - 6*

Menu structure *3 - 1*

Modules, connect *11 - 1*

Multigas Option *1 - 7, 1 - 1*

Multigas Option

 Install *1 - 1*

MultiVolume Inserts *1 - 7, G - 1*

N

No Analysis, file status *3 - 6*

O

O-ring

 chamber cap, grease *12 - 4*

 chamber cap, replace *12 - 4*

Option presentation *3 - 5*

Options Report

 report options *8 - 5*

Overlay

 Generating Graph *7 - 20*

 Report Example *7 - 28*

Overlays

 generate *7 - 20*

 multiple graph *7 - 22*

 multiple sample *7 - 21*

P

- Parameter files
 - about 5 - 1
 - analysis 2 - 7
 - analysis conditions 5 - 2
 - directory 5 - 1
 - FoamPyc application 5 - 4
- Parts and Accessories 13 - 1
- Power failure, recover from 12 - 10
- Presentation option
 - advanced 4 - 2
 - sample files 4 - 2
- Pressure and Volume Table
 - report options 8 - 5
- Print files 2 - 13, 3 - 11
- Printer, setup 11 - 3, J - 11
- Pycnometer
 - clean 12 - 10
 - configure J - 10
 - High Pressure Core 1 - 7
 - Large Volume Core 1 - 7
- Pycnometer Configuration Diagrams J - 2
- Pycnometer Set up J - 2
- Pycnometer, configure J - 10

Q

- QuickStart Analysis 6 - 6

R

- Recalculate SPC values
 - regression report 7 - 3
- Regression Report 7 - 2
 - recalculate SPC values 7 - 3
- Regulator Pressure, S set with software 12 - 14
- Regulator Pressure, set 12 - 14
- Regulator Pressure, set with keypad 12 - 15
- Report Example
 - Graph 7 - 27
 - Overlay 7 - 28
 - Sample Log 7 - 30
 - Summary 7 - 25

- Tabular 7 - 26
- Report examples 7 - 24
 - Combined Report 7 - 24
- Report header shortcuts 7 - 10
- Report Options 5 - 5
 - Density and Volume Table 8 - 1
 - Density vs Cycle Number 8 - 2
 - Density vs Time 8 - 3
 - Equilibration Report 8 - 4
 - Options Report 8 - 5
 - Pressure and Volume Table 8 - 5
 - Sample Log Report 8 - 5
 - Summary Report 8 - 6
 - Total Pore Volume vs Temp. 8 - 7
 - Volume vs Cycle 8 - 8
- Reports
 - about 7 - 1
 - axis cross-hair 7 - 17
 - calibration 10 - 1
 - Combined Report 8 - 1
 - Control Chart 7 - 5
 - Features and Shortcuts 7 - 9
 - generate graph overlays 7 - 22
 - generate sample overlays 7 - 21
 - graph grid lines 7 - 18
 - open and close 7 - 1
 - Regression 7 - 2
 - setup using keypad 2 - 9
 - SPC 7 - 2
 - start 7 - 1
 - Tabular 8 - 6
 - toolbar 7 - 11
 - zoom feature 7 - 18
- Reset pressure calibration 10 - 5
- Reset pycnometer 12 - 11
- Review, data 2 - 11
- RS-232 Pin Assignment E - 1
- Run Precision B - 6

S

- Sample
 - Load 6 - 1
 - Prepare 6 - 1
- Sample cups
 - install and remove G - 3
 - properties 4 - 5

Sample Defaults 3 - 8
 edit 3 - 8
 Sample file
 advanced 4 - 2
 basic presentation option 4 - 4
 create 4 - 2
 defined 4 - 1
 open 3 - 12
 Sample log
 report 8 - 5
 Sample Log
 Report Example 7 - 30
 Sample overlays 7 - 21
 Sample Volume Equation Derivation C - 1
 Schematic
 instrument 3 - 9
 shortcut menus 3 - 10
 Selected Reports 8 - 1
 Sequence Analysis 6 - 8
 Shortcuts
 application 3 - 7
 keyboard 3 - 7
 menu 3 - 7
 report header 7 - 10
 schematic 3 - 10
 Show instrument log 3 - 8
 Show instrument schematic 3 - 9
 Software
 about 1 - 6
 reinstall or modify J - 21
 uninstall 3 - 13, J - 22
 Software Installation J - 15
 SPC report 7 - 2
 SPC Report Variables B - 8
 Specific Gravity B - 10
 Specifications 1 - 10
 Start the Application J - 19
 Status
 analyzer 3 - 10
 Summary
 Report Example 7 - 25
 Summary Report 8 - 6
 System Setup J - 10

T

Tabular
 Report Example 7 - 26
 Tabular reports 8 - 6
 features and shortcuts 7 - 19
 TEC Module 1 - 2, H - 1
 Asphalt Density Measurement H - 4
 operate H - 2
 set temperature H - 1, J - 4
 Temperature Controlled Module 1 - 9, F - 1
 Add an Analysis Module F - 1
 hardware setup J - 5
 Temperature offset, calibrate 10 - 2
 Toolbar, Report 7 - 11
 Total Pore Volume B - 6
 Total Pore Volume vs Temperature
 report options 8 - 7
 Total Solids Concentration B - 7
 Trademarks 2
 Transmit 2 - 6
 Transmitted Data
 Analysis Report D - 1
 Calibration Report D - 3
 data units D - 1
 Troubleshooting 12 - 1

U

Unit selections J - 19
 Unit types J - 13

V

Volume
 calibrate 10 - 15
 Volume Offset B - 4
 Volume Scale B - 4
 calibrate 10 - 6
 Volume vs Cycle
 report options 8 - 8

W

Warranty *i*

Web Browser, Review Data with *2 - 11*

Z

Zero Cell Volume, calibrate *10 - 2*

Zero Pressure, calibrate *10 - 4*