

# KUKA

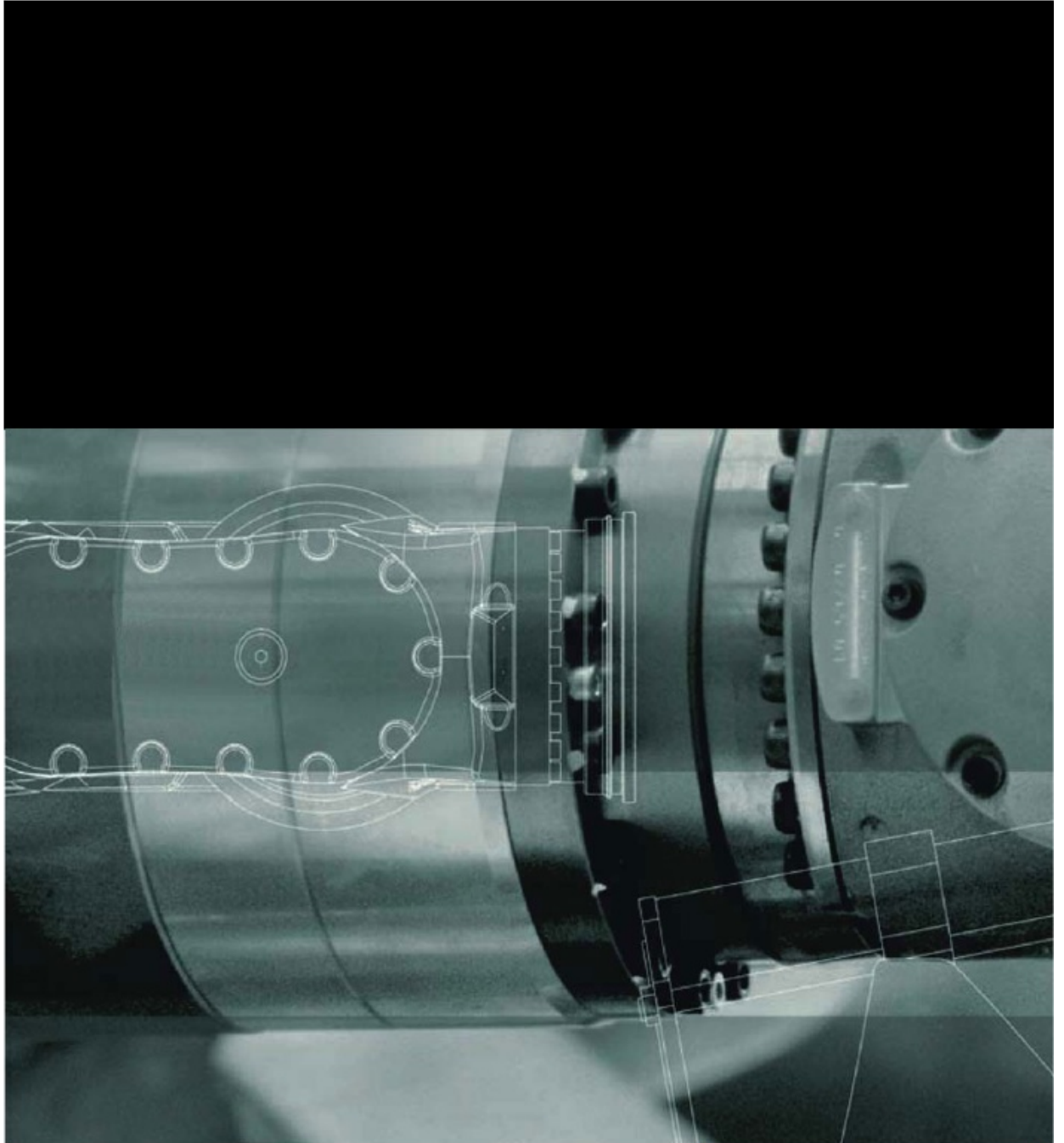

Issued: 21.01.2014

Version: KR C4 EtherCAT Bridge V1



© Copyright 2014

KUKA Roboter GmbH  
Zugspitzstraße 140  
D-86165 Augsburg  
Germany

This documentation or excerpts therefrom may not be reproduced or disclosed to third parties without the express permission of KUKA Roboter GmbH.

Other functions not described in this documentation may be operable in the controller. The user has no claims to these functions, however, in the case of a replacement or service work.

We have checked the content of this documentation for conformity with the hardware and software described. Nevertheless, discrepancies cannot be precluded, for which reason we are not able to guarantee total conformity. The information in this documentation is checked on a regular basis, however, and necessary corrections will be incorporated in the subsequent edition.

Subject to technical alterations without an effect on the function.

Translation of the original documentation

KIM-PS5-DOC

Publication:	Pub KR C4 EtherCAT Bridge (PDF) en
Book structure:	KR C4 EtherCAT Bridge V1.1
Version:	KR C4 EtherCAT Bridge V1

## Contents

<b>1</b>	<b>Introduction</b> .....	<b>5</b>
1.1	Target group .....	5
1.2	Industrial robot documentation .....	5
1.3	Representation of warnings and notes .....	5
1.4	Trademarks .....	6
1.5	Terms used .....	6
<b>2</b>	<b>Product description</b> .....	<b>7</b>
2.1	Overview of EtherCAT bridge .....	7
<b>3</b>	<b>Safety</b> .....	<b>9</b>
<b>4</b>	<b>Configuration</b> .....	<b>11</b>
4.1	Overview .....	11
4.2	Configuring the KR C4 as the primary controller .....	11
4.3	Configuring the KR C4 as the secondary controller .....	11
4.4	“Slave settings” tab .....	12
<b>5</b>	<b>Diagnosis</b> .....	<b>15</b>
5.1	Diagnosing the state .....	15
<b>6</b>	<b>KUKA Service</b> .....	<b>17</b>
6.1	Requesting support .....	17
6.2	KUKA Customer Support .....	17
	<b>Index</b> .....	<b>25</b>



# 1 Introduction

## 1.1 Target group

This documentation is aimed at users with the following knowledge and skills:

- Advanced KRL programming skills
- Advanced knowledge of the robot controller system
- Advanced knowledge of field buses
- Knowledge of WorkVisual

## 1.2 Industrial robot documentation

The industrial robot documentation consists of the following parts:

- Documentation for the manipulator
- Documentation for the robot controller
- Operating and programming instructions for the System Software
- Instructions for options and accessories
- Parts catalog on storage medium

Each of these sets of instructions is a separate document.

## 1.3 Representation of warnings and notes

### Safety

These warnings are relevant to safety and **must** be observed.

 **DANGER** These warnings mean that it is certain or highly probable that death or severe injuries **will** occur, if no precautions are taken.

 **WARNING** These warnings mean that death or severe injuries **may** occur, if no precautions are taken.

 **CAUTION** These warnings mean that minor injuries **may** occur, if no precautions are taken.

 **NOTICE** These warnings mean that damage to property **may** occur, if no precautions are taken.

 These warnings contain references to safety-relevant information or general safety measures.  
These warnings do not refer to individual hazards or individual precautionary measures.

This warning draws attention to procedures which serve to prevent or remedy emergencies or malfunctions:

 **SAFETY INSTRUCTIONS** Procedures marked with this warning **must** be followed exactly.

### Notes

These hints serve to make your work easier or contain references to further information.

 Tip to make your work easier or reference to further information.

## 1.4 Trademarks



is a trademark of Beckhoff Automation GmbH.

## 1.5 Terms used

Term	Description
PLC	Programmable logic controller
WorkVisual	Configuration software from KUKA for field bus configuration

## 2 Product description

### 2.1 Overview of EtherCAT bridge

EtherCAT bridge can be used to establish communication between an external controller (i.e. PLC) and a KR C4 if both controllers are configured as master in their bus line.

To make this possible, EtherCAT bridge must be configured as a slave on both sides. EtherCAT bridge forwards the received data from one line to the other. This enables the exchange of large amounts of data at the bus clock rate.

EtherCAT bridge consists of a bus coupler and the EtherCAT bridge terminal. The controller connected to the bus coupler is the primary controller. The controller connected to the bridge terminal is the secondary controller. Which controller is configured as primary or secondary depends on which bus line the bridge terminal is mounted on.

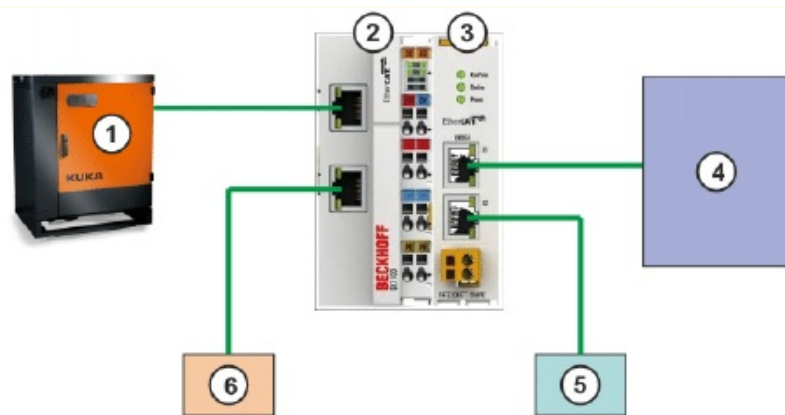

**Fig. 2-1: KR C4 as the primary controller**

- 1 KR C4 (primary controller)
- 2 Bus coupler (here: EK1100)
- 3 Bridge terminal EL6692
- 4 External controller (secondary controller)
- 5 EtherCAT device on the external controller
- 6 EtherCAT device on the KR C4

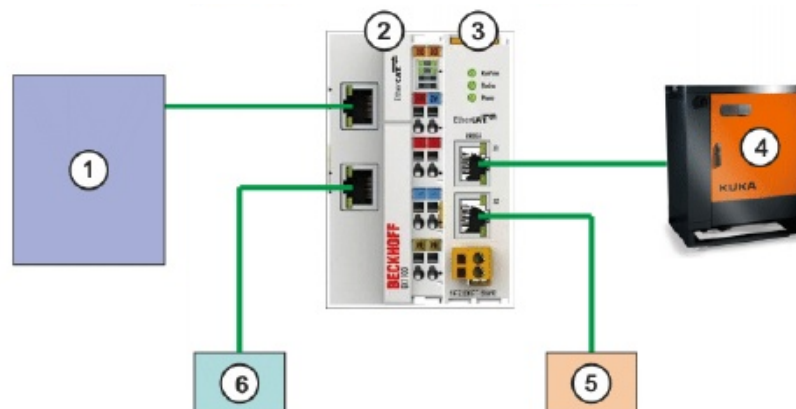

**Fig. 2-2: Third-party controller as the primary controller**

- 1 External controller (primary controller)
- 2 Bus coupler (here: EK1100)

- 3 Bridge terminal EL6692
- 4 KR C4 (secondary controller)
- 5 EtherCAT device on the KR C4
- 6 EtherCAT device on the external controller

**Configuration software**

EtherCAT bridge is configured on a laptop or PC. The following software is required for configuration:

- WorkVisual 3.1

The requirements for installation of WorkVisual are contained in the WorkVisual documentation.



### 3 Safety

This documentation contains safety instructions which refer specifically to the product described here. The fundamental safety information for the industrial robot can be found in the “Safety” chapter of the operating or assembly instructions for the robot controller.

**WARNING**

The “Safety” chapter in the operating instructions or assembly instructions of the robot controller must be observed. Death to persons, severe injuries or considerable damage to property may otherwise result.



## 4 Configuration

### 4.1 Overview

The configuration depends on whether the KR C4 is to be configured as the primary or secondary controller:

- KR C4 as the primary controller  
(>>> 4.2 "Configuring the KR C4 as the primary controller" Page 11)
- KR C4 as the secondary controller  
(>>> 4.3 "Configuring the KR C4 as the secondary controller" Page 11)



Information about procedures in WorkVisual is contained in the WorkVisual documentation. Information about procedures in the configuration software from the manufacturer of the higher-level controller can be found in the documentation for this configuration software.

### 4.2 Configuring the KR C4 as the primary controller

**Precondition** ■ A robot controller has been added and set as active.

- Procedure**
1. Expand the tree structure of the robot controller on the **Hardware** tab in the **Project structure** window.
  2. Right-click on **Bus structure** and select **Add...** from the context menu.
  3. A window opens. Select the entry **KUKA Extension Bus (SYS-X44)** and confirm with **OK**. The entry is inserted in the tree structure.
  4. Expand the tree structure as far as possible. Right-click on **EtherCAT** and select **Add...** from the context menu.
  5. A window opens. Select a bus coupler, e.g. **EK1100 EtherCAT coupler (2A E-Bus)**, and confirm with **OK**. The bus coupler is inserted in the tree structure.
  6. Expand the tree structure as far as possible. Right-click on **EBus** and select **Add...** from the context menu.
  7. A window opens. Select the entry **EL6692 EtherCAT bridge terminal (primary)** and confirm with **OK**. The terminal is inserted in the tree structure.
  8. Right-click on the terminal and select **Settings...** from the context menu. A window opens with the settings.
  9. Enter the number of inputs and outputs on the **Slave settings** tab.  
(>>> 4.4 "Slave settings" tab" Page 12)
  10. Save the settings by selecting **OK**.

### 4.3 Configuring the KR C4 as the secondary controller

**Precondition** ■ A robot controller has been added and set as active.

- Procedure**
1. Expand the tree structure of the robot controller on the **Hardware** tab in the **Project structure** window.
  2. Right-click on **Bus structure** and select **Add...** from the context menu.
  3. A window opens. Select the entry **KUKA Extension Bus (SYS-X44)** and confirm with **OK**. The entry is inserted in the tree structure.
  4. Expand the tree structure as far as possible. Right-click on **EtherCAT** and select **Add...** from the context menu.

5. A window opens. Select the entry **EL6692 EtherCAT bridge terminal (secondary)** and confirm with **OK**. The terminal is inserted in the tree structure.
6. Right-click on the terminal and select **Settings...** from the context menu. A window opens with the settings.
7. Enter the number of inputs and outputs on the **Slave settings** tab, inversely matching the settings for the primary terminal.  
(>>> 4.4 "Slave settings" tab" Page 12)
8. Save the settings by selecting **OK**.

#### 4.4 "Slave settings" tab

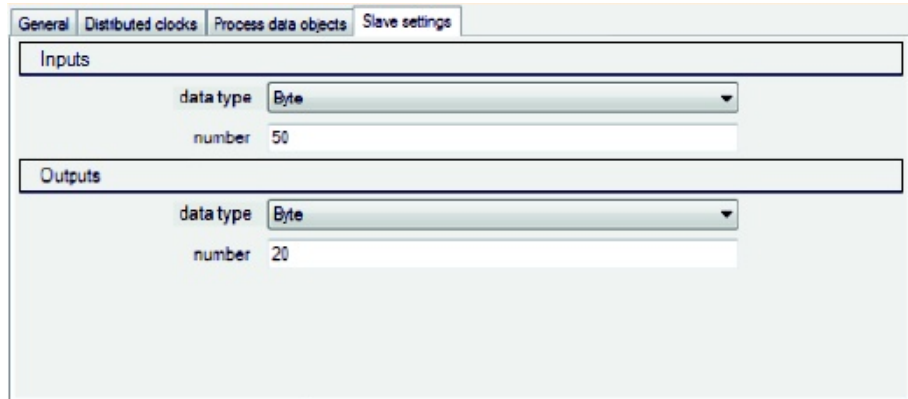

Fig. 4-1: "Slave settings" tab

Box	Description
Inputs	
Data type	Select the data type of the inputs. <ul style="list-style-type: none"> <li>■ <b>Bit</b></li> <li>■ <b>Byte</b></li> <li>■ <b>Word</b></li> <li>■ <b>DWord</b></li> <li>■ <b>LWord</b></li> </ul> <b>Note:</b> The selected data type is displayed in the mapping editor.
Number	Enter the number of inputs. <ul style="list-style-type: none"> <li>■ <b>0 ... 59</b></li> </ul> <b>Note:</b> For the <b>Bit</b> data type, the number must be divisible by 8.
Outputs	

Box	Description
Data type	<p>Select the data type of the outputs.</p> <ul style="list-style-type: none"><li>■ <b>Bit</b></li><li>■ <b>Byte</b></li><li>■ <b>Word</b></li><li>■ <b>DWord</b></li><li>■ <b>LWord</b></li></ul> <p><b>Note:</b> The selected data type is displayed in the mapping editor.</p>
Number	<p>Enter the number of outputs.</p> <ul style="list-style-type: none"><li>■ <b>0 ... 59</b></li></ul> <p><b>Note:</b> For the <b>Bit</b> data type, the number must be divisible by 8.</p>



## 5 Diagnosis

### 5.1 Diagnosing the state

The state of the opposite bus line can be diagnosed with the signal **SYNC Inputs External device not connected**.

 In the event of an error on the opposite bus line, the motion enable command is not canceled!

#### Procedure

- The signal **SYNC Inputs External device not connected** is mapped to an output. The value that is returned at the output provides information regarding the state of the opposite bus line:

Return value	Description
TRUE	The opposite bus line has an error.
FALSE	The opposite bus line is OK.





## 6 KUKA Service

### 6.1 Requesting support

<b>Introduction</b>	This documentation provides information on operation and operator control, and provides assistance with troubleshooting. For further assistance, please contact your local KUKA subsidiary.
<b>Info</b>	<p>The following information is required for processing a support request:</p> <ul style="list-style-type: none"> <li>■ Model and serial number of the manipulator</li> <li>■ Model and serial number of the controller</li> <li>■ Model and serial number of the linear unit (if present)</li> <li>■ Model and serial number of the energy supply system (if present)</li> <li>■ Version of the system software</li> <li>■ Optional software or modifications</li> <li>■ Diagnostic package <b>KrcDiag</b>:            Additionally for KUKA Sunrise: Existing projects including applications            For versions of KUKA System Software older than V8: Archive of the software (<b>KrcDiag</b> is not yet available here.)</li> <li>■ Application used</li> <li>■ External axes used</li> <li>■ Description of the problem, duration and frequency of the fault</li> </ul>

### 6.2 KUKA Customer Support

<b>Availability</b>	KUKA Customer Support is available in many countries. Please do not hesitate to contact us if you have any questions.
<b>Argentina</b>	<p>Ruben Costantini S.A. (Agency)          Luis Angel Huergo 13 20          Parque Industrial          2400 San Francisco (CBA)          Argentina          Tel. +54 3564 421033          Fax +54 3564 428877  <a href="mailto:ventas@costantini-sa.com">ventas@costantini-sa.com</a></p>
<b>Australia</b>	<p>Headland Machinery Pty. Ltd.          Victoria (Head Office &amp; Showroom)          95 Highbury Road          Burwood          Victoria 31 25          Australia          Tel. +61 3 9244-3500          Fax +61 3 9244-3501  <a href="mailto:vic@headland.com.au">vic@headland.com.au</a>  <a href="http://www.headland.com.au">www.headland.com.au</a></p>

<b>Belgium</b>	KUKA Automatisering + Robots N.V. Centrum Zuid 1031 3530 Houthalen Belgium Tel. +32 11 516160 Fax +32 11 526794 info@kuka.be www.kuka.be
<b>Brazil</b>	KUKA Roboter do Brasil Ltda. Travessa Claudio Armando, nº 171 Bloco 5 - Galpões 51/52 Bairro Assunção CEP 09861-7630 São Bernardo do Campo - SP Brazil Tel. +55 11 4942-8299 Fax +55 11 2201-7883 info@kuka-roboter.com.br www.kuka-roboter.com.br
<b>Chile</b>	Robotec S.A. (Agency) Santiago de Chile Chile Tel. +56 2 331-5951 Fax +56 2 331-5952 robotec@robotec.cl www.robotec.cl
<b>China</b>	KUKA Robotics China Co.,Ltd. Songjiang Industrial Zone No. 388 Minshen Road 201612 Shanghai China Tel. +86 21 6787-1888 Fax +86 21 6787-1803 www.kuka-robotics.cn
<b>Germany</b>	KUKA Roboter GmbH Zugspitzstr. 140 86165 Augsburg Germany Tel. +49 821 797-4000 Fax +49 821 797-1616 info@kuka-roboter.de www.kuka-roboter.de

**France** KUKA Automatismes + Robotique SAS  
Techvallée  
6, Avenue du Parc  
91140 Villebon S/Yvette  
France  
Tel. +33 1 6931660-0  
Fax +33 1 6931660-1  
commercial@kuka.fr  
www.kuka.fr

**India** KUKA Robotics India Pvt. Ltd.  
Office Number-7, German Centre,  
Level 12, Building No. - 9B  
DLF Cyber City Phase III  
122 002 Gurgaon  
Haryana  
India  
Tel. +91 124 4635774  
Fax +91 124 4635773  
info@kuka.in  
www.kuka.in

**Italy** KUKA Roboter Italia S.p.A.  
Via Pavia 9/a - int.6  
10098 Rivoli (TO)  
Italy  
Tel. +39 011 959-5013  
Fax +39 011 959-5141  
kuka@kuka.it  
www.kuka.it

**Japan** KUKA Robotics Japan K.K.  
YBP Technical Center  
134 Godo-cho, Hodogaya-ku  
Yokohama, Kanagawa  
240 0005  
Japan  
Tel. +81 45 744 7691  
Fax +81 45 744 7696  
info@kuka.co.jp

**Canada** KUKA Robotics Canada Ltd.  
6710 Maritz Drive - Unit 4  
Mississauga  
L5W 0A1  
Ontario  
Canada  
Tel. +1 905 670-8600  
Fax +1 905 670-8604  
info@kukarobotics.com  
www.kuka-robotics.com/canada

<b>Korea</b>	KUKA Robotics Korea Co. Ltd. RIT Center 306, Gyeonggi Technopark 1271-11 Sa 3-dong, Sangnok-gu Ansan City, Gyeonggi Do 426-901 Korea Tel. +82 31 501-1451 Fax +82 31 501-1461 info@kukakorea.com
<b>Malaysia</b>	KUKA Robot Automation Sdn Bhd South East Asia Regional Office No. 24, Jalan TPP 1/10 Taman Industri Puchong 47100 Puchong Selangor Malaysia Tel. +60 3 8061-0613 or -0614 Fax +60 3 8061-7386 info@kuka.com.my
<b>Mexico</b>	KUKA de México S. de R.L. de C.V. Progreso #8 Col. Centro Industrial Puente de Vigas Tlalnepantla de Baz 54020 Estado de México Mexico Tel. +52 55 5203-8407 Fax +52 55 5203-8148 info@kuka.com.mx www.kuka-robotics.com/mexico
<b>Norway</b>	KUKA Sveiseanlegg + Roboter Sentrumsvegen 5 2867 Hov Norway Tel. +47 61 18 91 30 Fax +47 61 18 62 00 info@kuka.no
<b>Austria</b>	KUKA Roboter Austria GmbH Regensburger Strasse 9/1 4020 Linz Austria Tel. +43 732 784752 Fax +43 732 793880 office@kuka-roboter.at www.kuka-roboter.at

**Poland** KUKA Roboter Austria GmbH  
Spółka z ograniczoną odpowiedzialnością  
Oddział w Polsce  
Ul. Porcelanowa 10  
40-246 Katowice  
Poland  
Tel. +48 327 30 32 13 or -14  
Fax +48 327 30 32 26  
ServicePL@kuka-roboter.de

**Portugal** KUKA Sistemas de Automatización S.A.  
Rua do Alto da Guerra n° 50  
Armazém 04  
2910 011 Setúbal  
Portugal  
Tel. +351 265 729780  
Fax +351 265 729782  
kuka@mail.telepac.pt

**Russia** KUKA Robotics RUS  
Werbnaia ul. 8A  
107143 Moskau  
Russia  
Tel. +7 495 781-31-20  
Fax +7 495 781-31-19  
info@kuka-robotics.ru  
www.kuka-robotics.ru

**Sweden** KUKA Svetsanläggningar + Robotar AB  
A. Odhners gata 15  
421 30 Västra Frölunda  
Sweden  
Tel. +46 31 7266-200  
Fax +46 31 7266-201  
info@kuka.se

**Switzerland** KUKA Roboter Schweiz AG  
Industriestr. 9  
5432 Neuenhof  
Switzerland  
Tel. +41 44 74490-90  
Fax +41 44 74490-91  
info@kuka-roboter.ch  
www.kuka-roboter.ch

<b>Spain</b>	KUKA Robots IBÉRICA, S.A. Pol. Industrial Torrent de la Pastera Carrer del Bages s/n 08800 Vilanova i la Geltrú (Barcelona) Spain Tel. +34 93 8142-353 Fax +34 93 8142-950 Comercial@kuka-e.com www.kuka-e.com
<b>South Africa</b>	Jendamark Automation LTD (Agency) 76a York Road North End 6000 Port Elizabeth South Africa Tel. +27 41 391 4700 Fax +27 41 373 3869 www.jendamark.co.za
<b>Taiwan</b>	KUKA Robot Automation Taiwan Co., Ltd. No. 249 Pujong Road Jungli City, Taoyuan County 320 Taiwan, R. O. C. Tel. +886 3 4331988 Fax +886 3 4331948 info@kuka.com.tw www.kuka.com.tw
<b>Thailand</b>	KUKA Robot Automation (M)SdnBhd Thailand Office c/o Maccall System Co. Ltd. 49/9-10 Soi Kingkaew 30 Kingkaew Road Tt. Rachatheva, A. Bangpli Samutprakarn 10540 Thailand Tel. +66 2 7502737 Fax +66 2 6612355 atika@ji-net.com www.kuka-roboter.de
<b>Czech Republic</b>	KUKA Roboter Austria GmbH Organisation Tschechien und Slowakei Sezemická 2757/2 193 00 Praha Horní Počernice Czech Republic Tel. +420 22 62 12 27 2 Fax +420 22 62 12 27 0 support@kuka.cz

**Hungary**

KUKA Robotics Hungaria Kft.  
Fő út 140  
2335 Taksony  
Hungary  
Tel. +36 24 501609  
Fax +36 24 477031  
info@kuka-robotics.hu

**USA**

KUKA Robotics Corporation  
51870 Shelby Parkway  
Shelby Township  
48315-1787  
Michigan  
USA  
Tel. +1 866 873-5852  
Fax +1 866 329-5852  
info@kukarobotics.com  
www.kukarobotics.com

**UK**

KUKA Automation + Robotics  
Hereward Rise  
Halesowen  
B62 8AN  
UK  
Tel. +44 121 585-0800  
Fax +44 121 585-0900  
sales@kuka.co.uk





## Index

### C

Configuration 11  
Configuration, primary controller 11  
Configuration, secondary controller 11

### D

Diagnosis 15  
Documentation, industrial robot 5

### I

Introduction 5

### K

KUKA Customer Support 17

### O

Overview, EtherCAT bridge 7

### P

PLC 6  
Product description 7

### S

Safety 9  
Safety instructions 5  
Service, KUKA Roboter 17  
Slave settings (tab) 12  
State, diagnosing 15  
Support request 17

### T

Target group 5  
Terms used 6  
Terms, used 6  
Trademarks 6

### W

Warnings 5  
WorkVisual 6



