



TM5 Guide Book

The information contained herein is the property of Techman Robot Corporation (hereinafter referred to as the Corporation). No part of this publication may be reproduced or copied in any way, shape or form without prior authorization from the Corporation. No information contained herein shall be considered an offer or commitment. It may be subject to change without notice. This Manual should be reviewed periodically. The Corporation will not be liable for any error or omission.

 and  logos are the registered trademark of TECHMAN ROBOT INC. and the company reserves the ownership of this manual and its copy and its copyrights.

 達明機器人股份有限公司
TECHMAN ROBOT INC.

I Hardware Installation Manual

1. Safety Information	
1.1 Overview	2
1.2 Validation and Liability	2
1.3 Limitations on Liability	2
1.4 Warning and Caution Symbols	3
1.5 General Safety Warning	4
1.6 Scope of Use	5
1.7 Risk Assessment	5
1.8 Emergency Stop	6
1.9 Joint Rotation without Drive Power	6
2. Safety Functions and Interface	
2.1 Overview	8
2.2 Safe Stop Time	9
2.3 Safety-related Limiting Mechanisms	10
2.4 Safe Mode	10
2.5 Safety Setting	11
2.5.1 Operating Position	11
2.6 Operating Mode	12
2.6.1 Auto Mode	12
2.6.2 Manual Mode	12
2.6.2.1 Manual Control Mode	12
2.6.2.2 Trial Run Mode	13
2.6.3 Changing the Operating Mode	13
2.7 Hold to Run	13
3. Transportation	14
4. System Hardware	15
4.1 Overview	15
4.2 System Overview	15
4.2.1 Robot Arm	16
4.2.1.1 Robot Range of Motion	16
4.2.1.2 Robot Arm Maximum Allowed Payload	20
4.2.1.3 Robot Arm Installation	21
4.2.2 Robot End Module	22
4.2.2.1 End Module Components	22
4.2.2.2 End Flange Surface	24
4.2.2.3 End Mounting Caution	25
4.2.2.4 End Indication Light Ring Table	25
4.2.3 Control Box	26
4.2.3.1 Robot Stick	26
5. Electrical Interface	29
5.1 Overview	29
5.2 Electrical Warnings and Cautions	29
5.3 Control Box	30
5.3.1 Safety Connector	30

5.3.2 Power Connector	32
5.3.3 Digital In/Out	32
5.3.4 Analog In	34
5.3.5 Analog Out	35
5.3.6. EtherCAT: For EtherCAT Slave I/O Expansion	35
5.3.7 USB Port	35
5.4 Tool End I/O Interface	36
5.4.1 I/O Terminals	36
5.4.2 Connecting Tool End Digital Out	37
5.4.3 Connecting Tool End Digital In	37
5.4.4 Connecting Tool End Analog In	38
5.5 Control Box Interfaces	38
5.6 Control Box Power Interface and Robot Interface	39
5.6.1 Control Box Power Interface	39
5.6.2 Robot Interface	40
6. Maintenance and Repair	41
7. Warranty Statement	41
7.1 Product Warranty	42
7.2 Disclaimer	
Appendix A. Stop Time and Distance	43
Appendix B. Technical Specifications	44



Hardware Installation Manual

Hardware Version: 1.00
Software Version: 1.60

1. Safety Information

1.1 Overview

This chapter describes important safety information about the Techman Robot. The users and system integrators of the Techman Robot should carefully read and understand this chapter before using this robot.

1.2 Validation and Liability

The information contained herein neither includes how to design, install, and operate a complete robotic arm system, nor involves the peripherals which may affect the safety of the complete system. The design and installation of the complete system must comply with the safety standards and regulations in the country of use. The integrators of the robot should understand the safety laws and regulations in their countries and prevent major hazards from occurring in the complete system.

This includes but is not limited to:

- Risk assessment of the whole system;
- Adding other machines and additional safety mechanisms based on the results of the risk assessment;
- Building appropriate safety mechanisms in the software;
- Ensuring the user will not modify any safety-related measures;
- Ensuring all systems are correctly designed and installed;
- Clearly labeling user instructions;
- Clearly marked symbols for installation of the robot arm and the integrator contact details; and
- Collecting all documents into the technology folder, including the risk assessment, and this Manual.

1.3 Limitations on Liability

No safety-related information shall be considered a guarantee by Techman Robot that TM5 will not cause personnel injury or property damage.

1.4 Warning and Caution Symbols

The Table below shows the definitions of the warning and caution levels described in each paragraph of this Manual. Pay close attention to them when reading each paragraph, and observe them to avoid personal injuries or equipment damage.





Danger



Warning



Note

 Danger	This symbol indicates that failure to observe these instructions will lead to death or serious injuries.
 Warning	This symbol indicates that failure to observe these instructions may lead to injuries.
 Note	This symbol indicates that failure to observe these instructions may lead to equipment damage.

1.5 General Safety Warning

The following shows the general warnings and cautions. Note that there may be related warnings and cautions listed in the remaining sections, in addition to the ones described in this section. Read them carefully as well.



Danger:

1. Before handling, installation, operating, maintaining and servicing this product, carefully read the product's specifications and operating manual. Make sure that all conditions meet the requirements of the specifications and manual to avoid unexpected accidents during use (e.g. improper operation or operating conditions that exceed the product specifications) that may cause personnel injury or damage to this product.
2. Before using and installing this product, the installer must perform the necessary risk assessments based on the conditions of use to avoid serious personal injuries during operation (e.g. Collision between equipment and personnel) due to improper parameter settings.



Warning:

1. Before using this product, make sure that there is at least 1 or more emergency stop device on the machine to stop the movement of the robot in case of accidents. Always make sure that the devices are functioning properly.
2. Prior to assembly and disassembly, or servicing and maintenance of this product, make sure that the power is disconnected and the rear area is clear before proceeding. Doing so will help prevent injury to personnel or damage to equipment due to accidental short-circuits or electrocution during use.
3. When operating this product, the operator should not wear loose clothing or other accessories (e.g. necklaces, ties, and bracelets) to avoid injuries which may happen when said clothes or accessories are drawn into the machine during operation.
4. In the event of product malfunction, follow the proper procedures and channels to contact qualified personnel for troubleshooting and repair. To prevent damage to the equipment due to improper disassembly, the operator is strictly prohibited against attempting to make direct repairs.
5. Before the robot begins operations, make sure that each part is secured in place to prevent any accidents due to the robot being improperly secured during operation.
6. Before the robot begins operations, always make sure that no personnel or obstacles are within its range of motion. If the operating environment involves human-machine collaborative work, always perform the necessary risk assessments before the start of operations.
7. Unauthorized personnel are not allowed to operate this product in order to prevent any possibility of personal injury or damage to the machine caused by improper operation.
8. Do not install or operate this product in dangerous environments (e.g. in the presence of a strong magnetic field; dangerous gases; fire, or flammables) to avoid dangers which may occur due to external conditions during operation.



Note:

1. Personnel approaching or operating the robot should check the machine warning lights before proceeding.
2. After editing the task flow, always start operations in Manual Mode to check that all actions can be performed correctly during operation before switching the operating mode to Auto.
3. Do not turn off power to the machine while it is in motion unless absolutely necessary.

1.6 Scope of Use

The TM Robot is a collaborative robot with a built-in vision system. The dedicated HMI simplifies robot deployment and increases its operational flexibility, making it suitable for the production and manufacturing industries.

The design of the TM Robot focuses on the safety of the human-machine collaboration. However, the collaborative robot is intended only for the applications for which risk assessment has been conducted without any hazards identified. The risk assessment involves the robot and the related peripherals as well as environment.

The risk assessment has been performed for any use or application and no hazard is found. The use of the robot for any purpose other than the intended is prohibited. The Corporation shall not in any event be liable for any conditions including, but not limited to, the following:

- Use in a potentially hazardous environment
- Use in any applications that may threaten human lives
- Use in any application that may cause personal injuries
- Use before completion of the risk assessment
- Use for auxiliary support
- Use when the rated performance cannot be reached
- Use when the reaction time of safety functions is insufficient.
- Use with inappropriate parameters for operations
- Applications which may cause damage to the robot itself

1.7 Risk Assessment

Before using and installing this product, the user must perform the necessary risk assessments based on the conditions of use. Refer to the regulations specified in the documentation, such as ISO-10218-2, ISO-12100, and ISO-15066 for details. The purpose of the risk assessment is to predict possible accidents during the operation, and prevent the occurrence of accidents or reduce the severity of injuries effectively with appropriate protective measures. Therefore, the scope of the risk assessment must include any operation of the machine. Once a risk assessment has been conducted, the user may use the relevant external components (e.g. sensors, emergency stop devices, fencing or other barrier devices) and configuration of safety-related parameters in the operating system to prevent potential accidents during operations. External safety-related components should be installed as directed. Refer to Chapter 2 for the safety settings of the operating system and how other safety components should be used.

TM Robot expressly indicates that the major significant residual risk below may exist:

1. Excessive rotation of the 6th joint may result in the fingers being caught between the rear-end of the camera module and the 5th joint module.
2. The palm or fingers may get caught between the end module and the body of the robot during robot motion or Hand Guide Instruction.
3. Injuries due to collision with the robot.
4. Injuries due to being hit, crushed, or pinched between the robot and a hard surface.
5. Injuries caused by loose screws which are used to fix the robot to the base.
6. TM Robot explicitly states that serious residual risk may exist in the following scenarios: There is a risk that improper configuration of the collaborative zone or safety space, as well as the running of incorrect projects, may lead to the robot colliding at full speed with the human body within the collaborative space.

1.8 Emergency Stop

If any accidents occur during the operation of the robot, the user can stop all movement by pressing the Emergency Stop button. When the robot stops, the user must ensure that all fault conditions are eliminated before manually turning off the limit switch for the Emergency Stop button and restarting the robot. The Emergency Stop button is only used in critical conditions, to stop the robot during normal operations please use the Stop button on the system controller.

Once the risk assessment has been conducted, if an Emergency Stop button needs to be installed then the selected device must comply with the requirements of ISO-60204-1.



Warning

When an emergency button is pressed, the robot system issues a command to stop the robot, and stops supplying sufficient power to its joint actuators for an effect equivalent to disconnecting the power for the actuation of the robot. In this case, the braking device at each joint automatically locks the joint. However, before the brake completely stops the robot, the robotic link will, under the force of gravity, make the unpowered joint slightly droop in the direction of gravity. In this case, be aware of the possibility that the robot end module may pinch the body or collide with the surroundings.

1.9 Joint Rotation without Drive Power

1. When the Emergency Stop Button is triggered during the operation of the robot, the control system will stop its movement and cease supplying sufficient power to its joint actuators to achieve an effect equivalent to disconnecting the power for actuation to the robot. In this case, the brake at each joint automatically locks the joint to prevent each joint of the robot from drooping continuously under gravity. If the robot needs to be moved to clear the fault condition, press and hold the FREE button on the end module of the robot. Two seconds later, the braking device at the joint will disengage the brakes. Before releasing the FREE button, the user can move the machine by pushing the joint to clear the fault condition.

2. If the robot needs to be moved when the power is disconnected (e.g. disengaging packaging posture), the user can first press the Emergency Stop button while there is no power, then press the Power Button on the controller to supply power to the system. When the control system is turned on, the light blue indicator light on the end module will blink. At this time, press the FREE button on the end module to release the braking device at the joint. The user can move the joint by pushing it.



Danger

When overriding the brake during the movement without drive power, note that the robot limb will droop back down due to the gravity when the FREE button is pressed for 2 seconds. Be sure to grab the end module securely and prepare for the added weight when you press the FREE button to unlock the brake. Lift the end module upwards to avoid increasing the severity of injury if someone is caught under the machine. If the end module can't be held securely or you lack sufficient strength to prevent the robot arm from lowering, release the FREE button immediately. Each joint of the robot will be locked again to avoid personal injury or machine damage.

2. Safety Functions and Interface

2.1 Overview

The control system of the Techman Robot features a series of built-in safety-related functions, and provides an interface for connecting with external safety devices.



For human-machine collaborative tasks, the user or system integrator must configure the safety-related parameters based on the results of the risk assessment. For tasks during which human and machine are separated, evaluate the selection and configuration of external protection equipment. Failure to do so may result in personal injuries or death.

For instructions on how to configure the safety-related parameters in the UI, refer to Section 2.5. For instructions on how to connect external safety devices to the system, refer to Chapter 5.

Note:

1. The user or system integrator should configure the safety-related parameters based on the results of the risk assessment.
2. If any of the safety-related functions is triggered, protection stop is activated. Stop time is provided in Appendix A and this time should be considered as part of the task risk assessment.

The Techman Robot System limits physical values such as offset, speed, force, or even momentum and power, for the robot arm, tool end, and each movable axis. These are monitored and protected by dozens of safety-related protection functions through the real-time system. The figure below lists each protective function.

Limit condition / Limit type	Location	Speed/Momentum	Force/Power
Personnel limit / Robot	N.A	Maximum robot momentum	Maximum robot power
Personnel limit / Tool end	N.A	Maximum speed of tool end	Force Applied to Tool Endpoint
Personnel limit / Axis 1	Minimum/Maximum axis position	Maximum axis speed	Maximum axis torque
Personnel limit / Axis 2	Minimum/Maximum axis position	Maximum axis speed	Maximum axis torque
Personnel limit / Axis 3	Minimum/Maximum axis position	Maximum axis speed	Maximum axis torque
Personnel limit / Axis 4	Minimum/Maximum axis position	Maximum axis speed	Maximum axis torque
Personnel limit / Axis 5	Minimum/Maximum axis position	Maximum axis speed	Maximum axis torque
Personnel limit / Axis 6	Minimum/Maximum axis position	Maximum axis speed	Maximum axis torque



Warning

The "Force Applied to Tool Endpoint" is the external force which is applied at the center point of the tool, and estimated by models. It is not the protection value for the force externally applied by the robot system to the center point of the tool. When the external force applied to the center point of the tool estimated by the robot system exceeds this setting value, the event "Exceed Limit of Force Applied to Tool Endpoint" is triggered. At this time, the robot performs Category 2 Stop and starts deceleration. The robot may still apply force externally until it comes to a complete stop. Thus, it should be understood that the force externally applied by the robot during the period from this time to a complete stop will exceed this setting value. This setting must not be mistakenly used as a basis to assess the force of collision between human and machine.

2.2 Safe Stop Time

The safe stop time is defined as the period from the moment when the Emergency Stop button is pressed or any safety-related function is triggered to the moment when the robot comes to a complete stop. In this system, pressing the Emergency Stop Button is a Category 1 Stop, while triggering built-in safety-related functions or externally connected safety-related equipment is a Category 2 Stop. In certain cases, the user or system integrator must include this time in the risk assessment, because the robot may operate at a certain speed during this period, allowing transfer of energy, which may cause personal injury or equipment damage, please refer to Appendix A for the actual stopping distance.

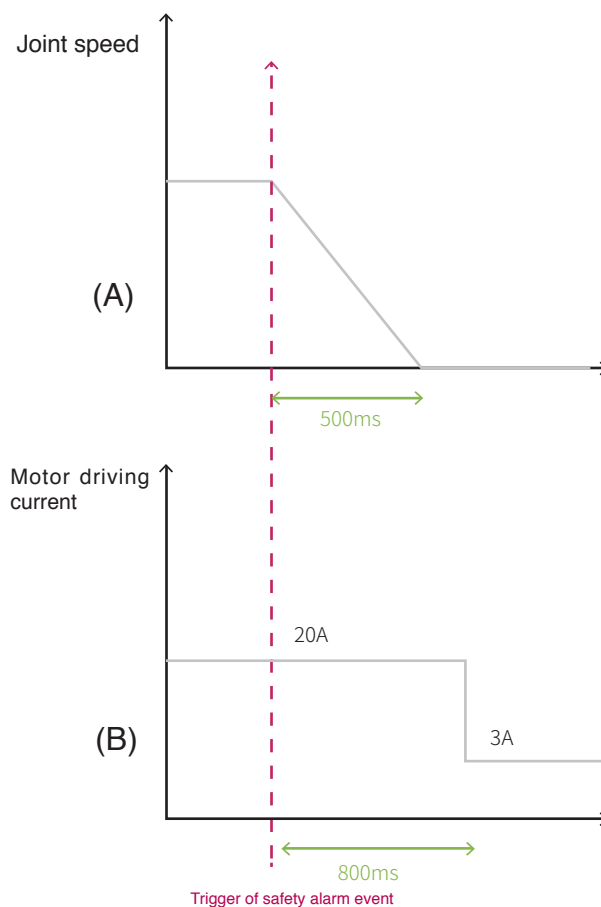

Both (A) and (B) are actuated during a Cat. 1 stop by the system; only (A) actuates during a Cat. 2 stop.

2.3 Safety-related Limiting Mechanisms

All safety-related functions described in Section 2.1 are monitored and controlled by a dedicated safety thread (with a cycle of 10ms) at system level, which provides a trigger signal to another dedicated motion thread (with a cycle of 1ms) to make related responses. In this dedicated safety thread, all physical quantities used for calculation of the required information about each robot axis (angle, angular velocity, torque, etc.) are also updated every 1ms. When any safety related function is triggered, every axis of the robot will stop within 800ms under a Category 2 Stop. When the Emergency Stop button is pressed, the robot will stop movement within 610ms and the system will lower the upper limit of the total drive current from 20 A to 3 A to activate a Category 1 Stop. In addition, when system hardware is operating beyond limits (such as too high joint drive current, overheating motor, unstable power supply, or disconnection of the system communications), a Category 2 Stop is triggered. When a Category 1 Stop or Category 2 Stop is triggered, the Indication Light Ring on the end of the robot will change to a solid red light and the system will beep continuously. When this happens, restart the system according to standard procedure, or contact the distributor for servicing.



Operating on the periphery of the non-working area of the Techman robot or if the range of motion passes through the non-working area (Jacobian matrix is unstable near singularities) may also cause the end tool output force to incorrectly trigger safety conditions even at low speeds. Please set the task requirements of the robot inside its working space to ensure the correct operation of the safety protection.

2.4 Safe Mode

The Techman Robot System has three safety modes: Normal, Reduced, and Recovery. Each mode has a safety limit as described in Section 2.1 which the user can set through HMI. It takes 250ms to switch between two modes. Other physical values described in Section 2.1 are also monitored and protected simultaneously, based on the settings of different modes.

When the robot enters Recovery Mode, it is stopped by a Category 2 Stop. The robot must now be guided by hand to return to Normal or Reduced Mode. At this time, the Hand Guide speed and other physical quantities are also protected by the safety limits of this mode.

2.5 Safety setting

The Techman robot system has three safety setting modes: Normal, Reduced, and Recovery. The user can configure the maximum allowable values of robot momentum, power consumption, TCP speed, TCP force, joint position, joint speed, and joint torque. Please note that the settings for Recovery mode should be large than those for Reduced mode, and the settings for Reduced mode should be large than those for Normal mode. Settings can be saved once they have been confirmed by the user.

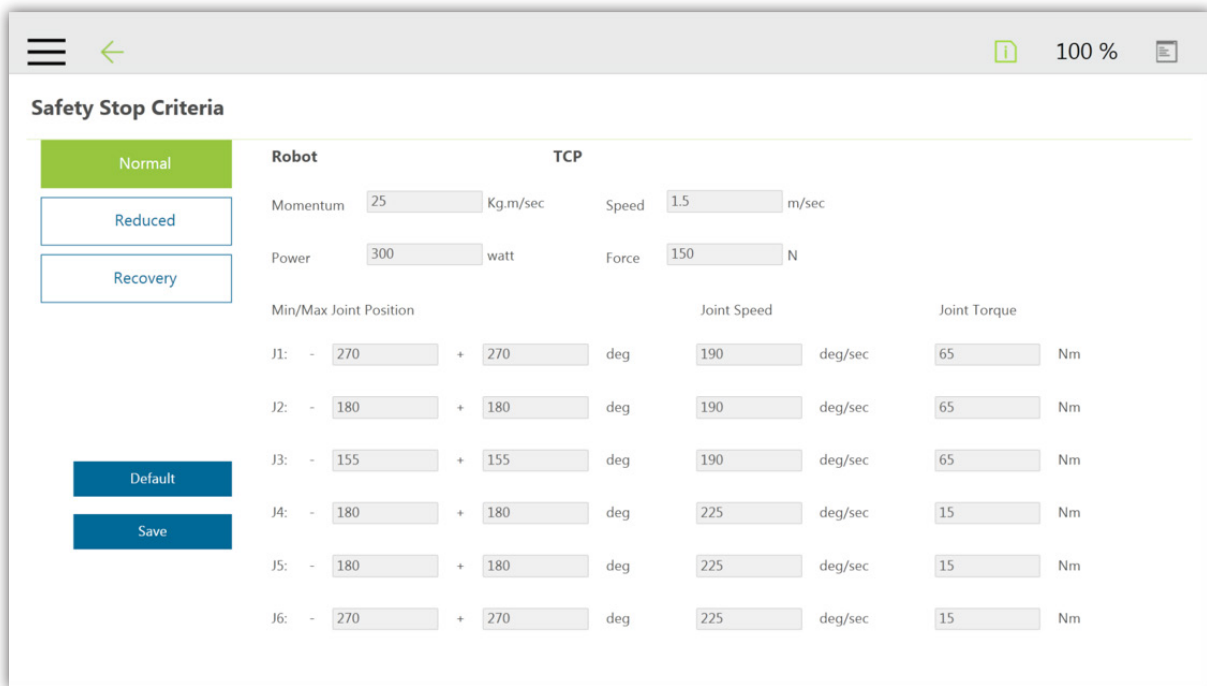

Robot		TCP			
Momentum	25 Kg.m/sec	Speed	1.5 m/sec		
Power	300 watt	Force	150 N		
Min/Max Joint Position		Joint Speed		Joint Torque	
J1:	- 270 + 270 deg	190 deg/sec	65 Nm		
J2:	- 180 + 180 deg	190 deg/sec	65 Nm		
J3:	- 155 + 155 deg	190 deg/sec	65 Nm		
J4:	- 180 + 180 deg	225 deg/sec	15 Nm		
J5:	- 180 + 180 deg	225 deg/sec	15 Nm		
J6:	- 270 + 270 deg	225 deg/sec	15 Nm		

2.5.1 Operating Position

In addition to Hand Guide Mode, for correct operating positions, the user should stay outside of the motionrange of the robot to perform operations. At least one emergency switch is installed outside of the motionrange of the robot. When no motion limit is set for the robot, the motion range of the robot is equal to the maximum motion range of the robot arm (refer to Section 4.2.1). When the user sets a limit for the TM Robot, he/she can avoid the situation whereby all operations have to be out of the maximum motion range of the robot arm.

The robot stick should be placed in an area that the robot cannot reach. The user should also make sure that the movement of the robot will not be within any area where personnel will enter to press any buttons on the robot stick.

2.6 Operating Mode

TM Robot comes with two operating modes: Manual Mode and Auto Mode. Current mode can be determined visually via the mode indicator (see Section 4.2.3.1) on the Robot Stick, and the color of the Indication Light Ring on the robot's end module (see Section 4.2.2.4). The robot starts in Auto Mode.

2.6.1 Auto Mode

When the robot is in Auto Mode the Indication Light Ring on the end module is blue and the mode indicator on the Robot Stick is in the Auto position. Under auto mode, pressing the Play/Pause buttons on the Robot Stick runs or pauses the project. Robot speed is determined by the project speed. The FREE button of the end module does not work under Auto Mode so there is no guiding by hand.

2.6.2 Manual Mode

When the robot is in Manual Mode the Indication Light Ring on the end module is green and the mode indicator on the Robot Stick is in the Manual position. Manual Mode can be further broken down into Manual Control mode and Trial Run mode. The user can tell the difference using the status of the green Indication Light Ring on the end module as well. Constant green light indicates Manual Control mode while flashing green light indicates Trial Run mode.

2.6.2.1 Manual Control Mode

In Manual Mode, if the robot is not moving then it is in Manual Control mode. Press the FREE button on the end module to guide the robot by hand or use the controller page to jog the robot. When the robot is in Manual Control Mode, all robot motion will be limited to less than 250mm/sec. If the robot speed exceeds 250mm/sec then it will stop on an error.

2.6.2.2 Trial Run Mode

When the user is in the HMI's project editing page, pressing the Play/Pause button on the Robot Stick enters Trial Run mode. The 250mm/sec speed limit does not apply while editing projects in Trial Run mode but the project run speed will be reduced to 10% during each trial run. The add/subtract buttons on the Robot Stick can be used to adjust the project run speed in Trial Run mode. Each button press increases or decreases project run speed by 5%. This is used to adjust the project run speed.

2.6.3 Changing the Operating Mode

To change the operating mode of the robot, please use the Switch Mode Button on the robot control to cycle between Auto/Manual mode. The system cannot be changed from Auto to Manual mode while the robot is running a project in Auto mode. The robot must be stopped by pressing the Stop Button on the Robot Stick before it can be switched to Manual mode. When the robot is switched from Trial Run mode to Auto mode by pressing the Change Mode button, the project run speed will be set to the default project running speed. In other words, the run speed in Auto mode for this project will now be fixed unless it is changed by another trial run.

2.7 Hold to Run

TM Robot can not only record points through hand guide instruction but also use TM Flow to move the coordinates of each coordinate system. These include: moving the joint angle, moving the end module through the robot coordinate system, moving the end module through the tool coordinate system, moving the end module through a custom coordinate system, moving to the vision initialization position, visual servo operations, execute step run function, and move to point. In all of the above functions, a hold to run design was adopted by TM Robot for enhanced safety. There are two types of hold to run in the TM Robot system. For operations with a higher level risk, the Robot Stick should be used to carry out different types of hold to run functions. Type 1 is holding down the add/subtract buttons on the Robot Stick to keep the robot moving. Type 2 is holding down the software buttons on the HMI to keep the robot moving. Both move the robot while the button is held down and stops immediately when the physical or virtual button is released. The robot will resume running if the button is held down again. Some of the functions can be used by both types of hold to run functions so the user can choose one of the Types to operate. However, if you are using the software hold to run button from a HMI connected to the robot via TCP/IP or Wi-Fi, if the network is disconnected then the TM Robot system will automatically disengage the robot and make it stop. In this situation however, it may take up to 0.7 second for a disconnection to be detected under different network environments. This means that even if you release the software button the robot may continue to execute the original command. If the physical button on the Robot Stick is used for hold to run, the system's detection time for button release is 30 ms. For operations with a higher level risk, the Robot Stick should therefore be used with all hold to run operations.

3. Transportation

Transport the Techman Robot using its original packing materials. If you will need to transport the Techman Robot after unpacking, store the packing materials in a dry place. Hold both arms of the Techman Robot during transportation. Support the arms before tightening the base screws.

Transport the control box by its handles. Store the cables before transportation.



Warning

Pay attention to your posture when moving the arm and control box cartons to avoid back injury. Techman Robot will not be liable for any injuries caused during transportation.

4. System Hardware

4.1 Overview

This chapter introduces the mechanical interface of the Techman Robot System.

4.2 System Overview

Techman Robot is made up of the robot arm and control box (including a robot stick).



Robot arm



Control Box



Robot Stick

4.2.1 Robot Arm

4.2.1.1 Robot Range of Motion

Techman Robot's working range is a spherical space with a 700mm radius at the base (for TM5-900, it is a 900mm radius). Due to the limitations of configuration, try to avoid moving the center of the tool to the cylindrical space below and above the base.

TM5-700 Movement Range Diagram

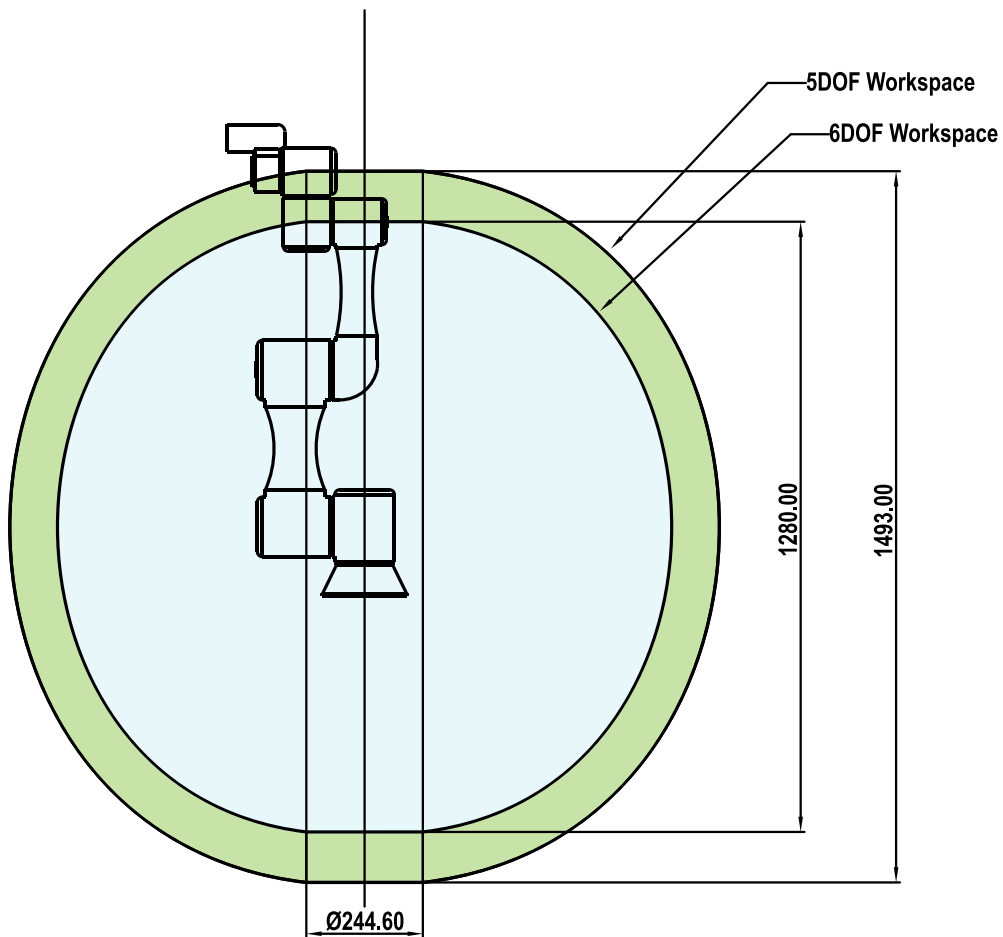

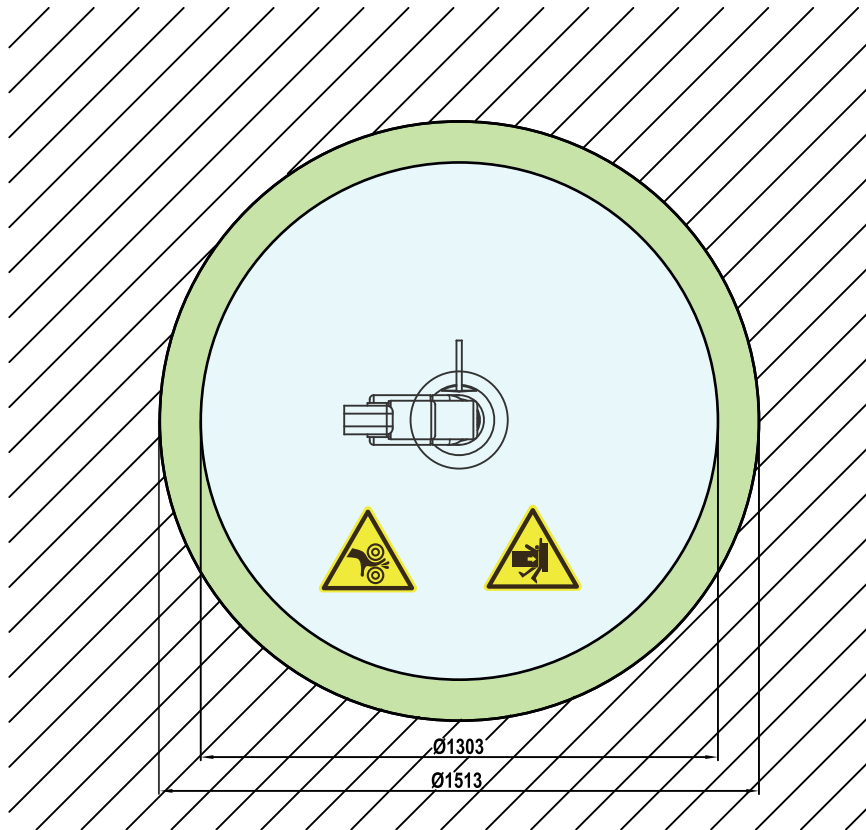

Operator Position



Warning: Risk of crushing within the operating area of the arm.



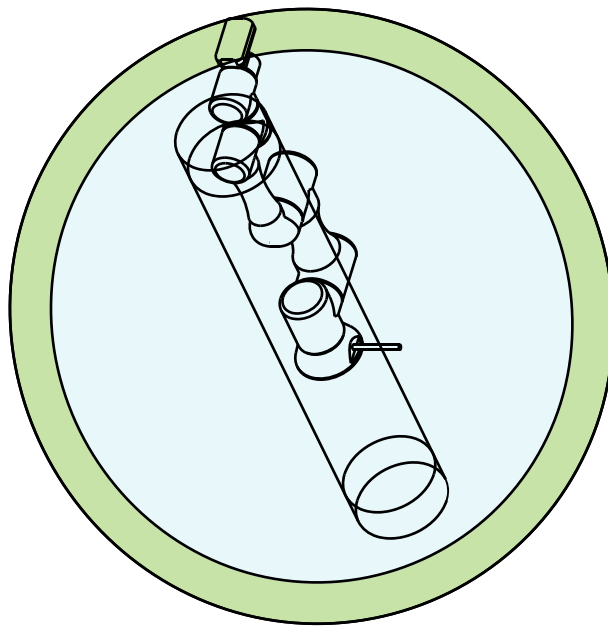

Warning: Risk of collision within the operating area of the arm.

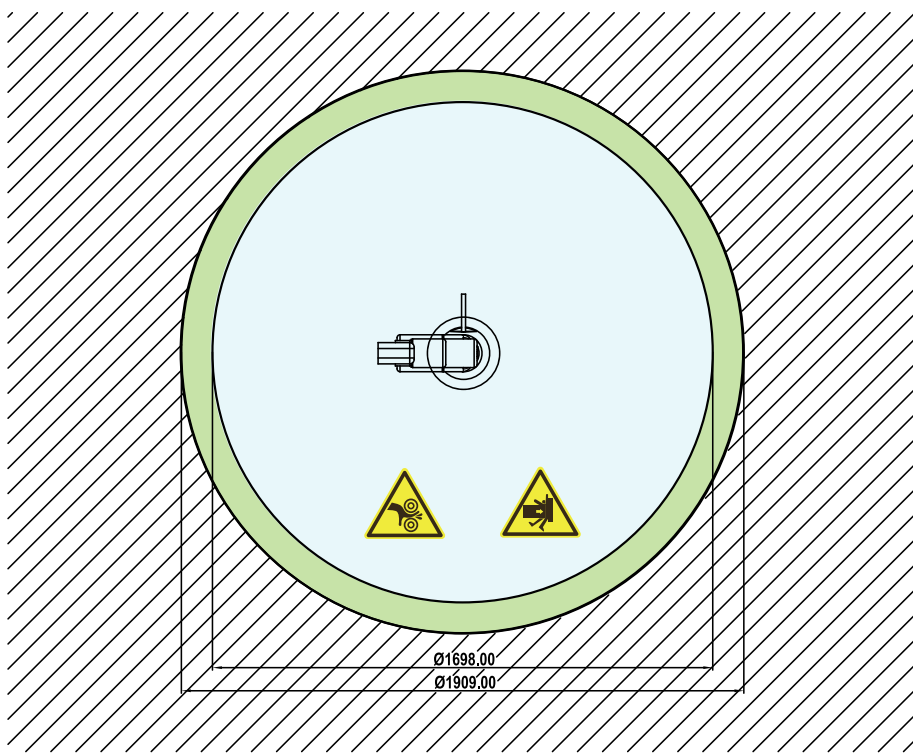
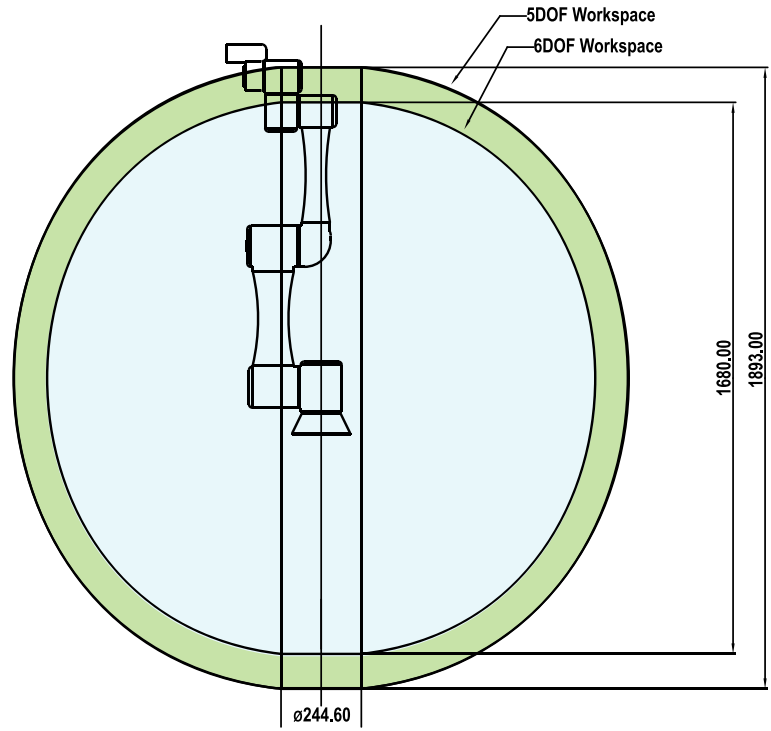

TM5-900 Movement Range Diagram



 Operator Position

 Warning: Risk of crushing within the operating area of the arm.

 Warning: Risk of collision within the operating area of the arm.

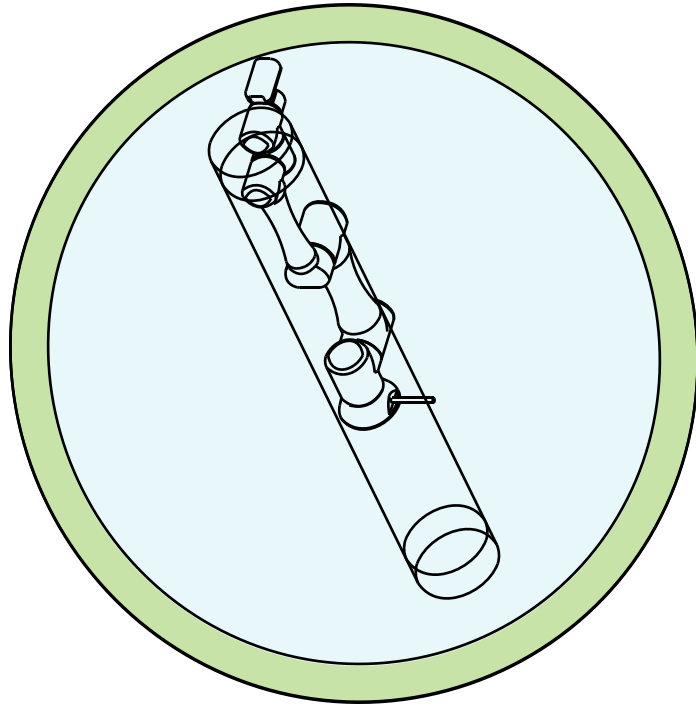

4.2.1.2 Robot Arm Maximum Allowed Payload

The maximum allowed payload of the robot arm is related to its center of gravity offset, which is defined as the distance from the center point of tool flange to the payload's center of gravity. The following figure shows the relationship between payload and the center of gravity offset:

TM5-700/TM5X-700

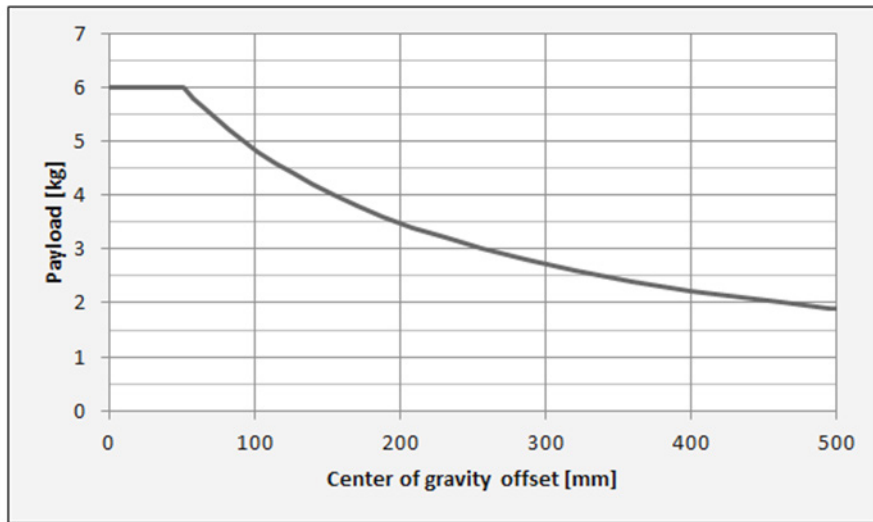

TM5-900/TM5X-900

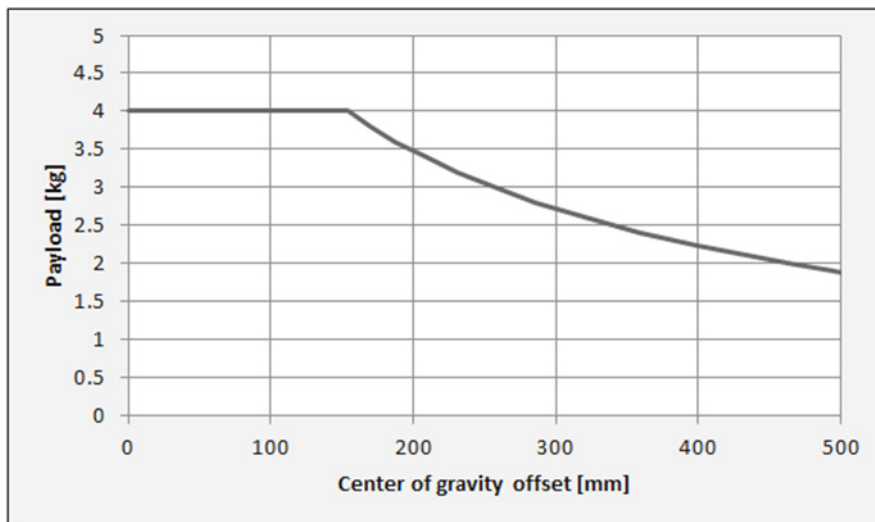

4.2.1.3 Robot Arm Installation

The TM5 is secured by four holes with a diameter of 11mm on the base and four M10 screws. A tightening torque of 35Nm (can be adjusted based on the strength of the bolts used) is recommended. If your application requires more precision, you can use two positioning pins with a diameter of 6mm for a more secure mounting.



1. The Techman Robot must be securely and tightly screwed down before use. The mounting surface should have sufficient strength.
2. Do not immerse the Techman Robot in water. Installation in the water or a humid environment may lead to damage.

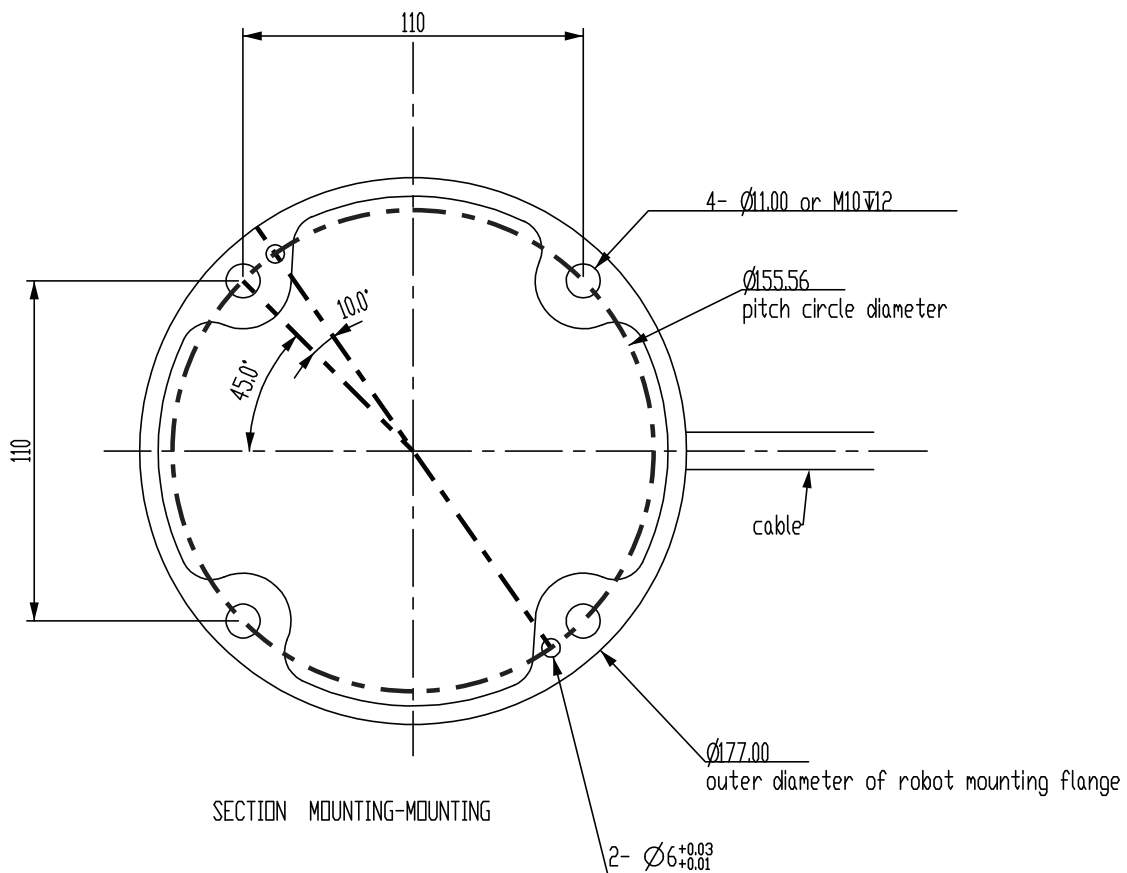

4.2.2 Robot End Module

4.2.2.1 End Module Components

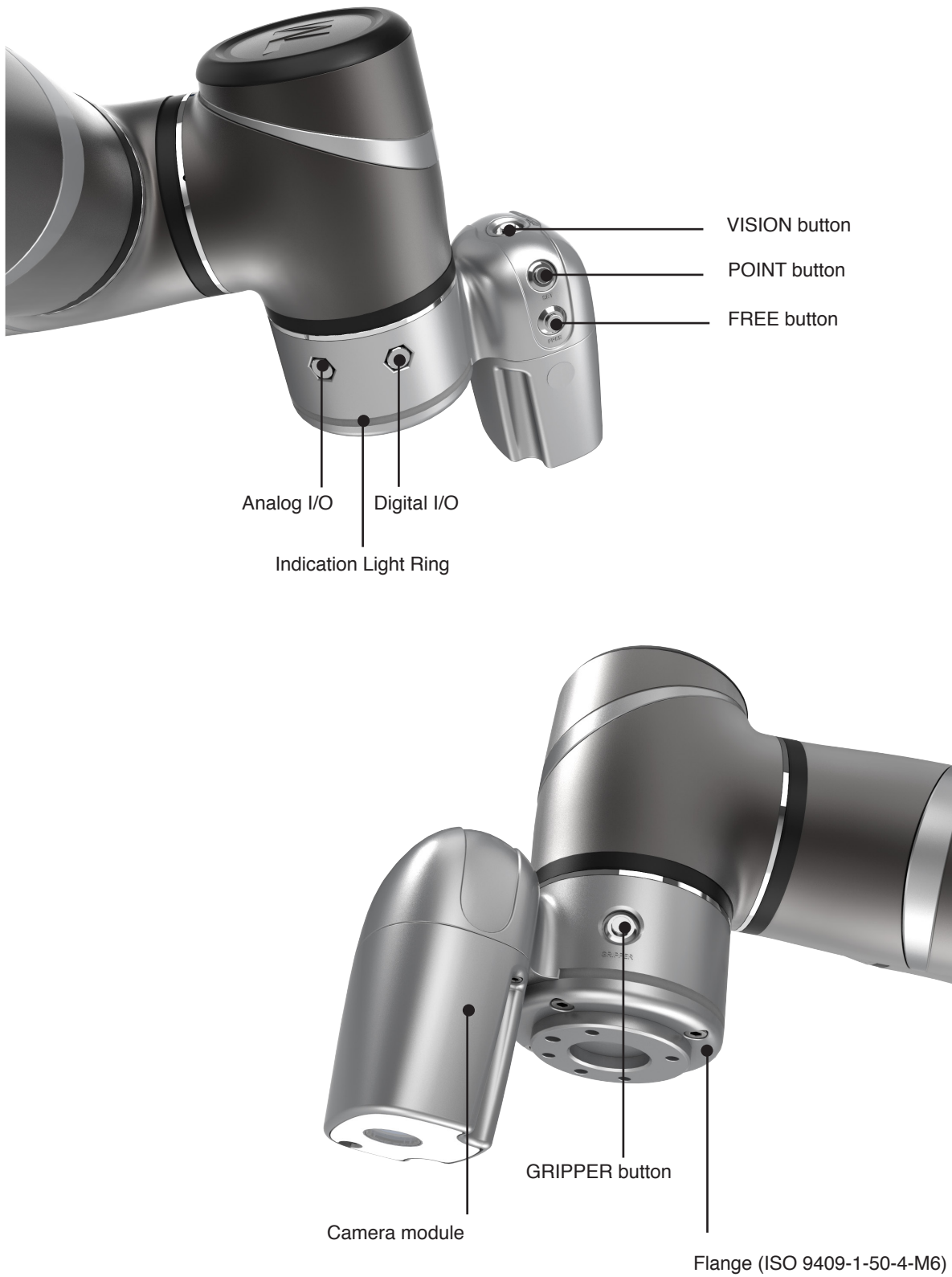

TM5X End Module Components

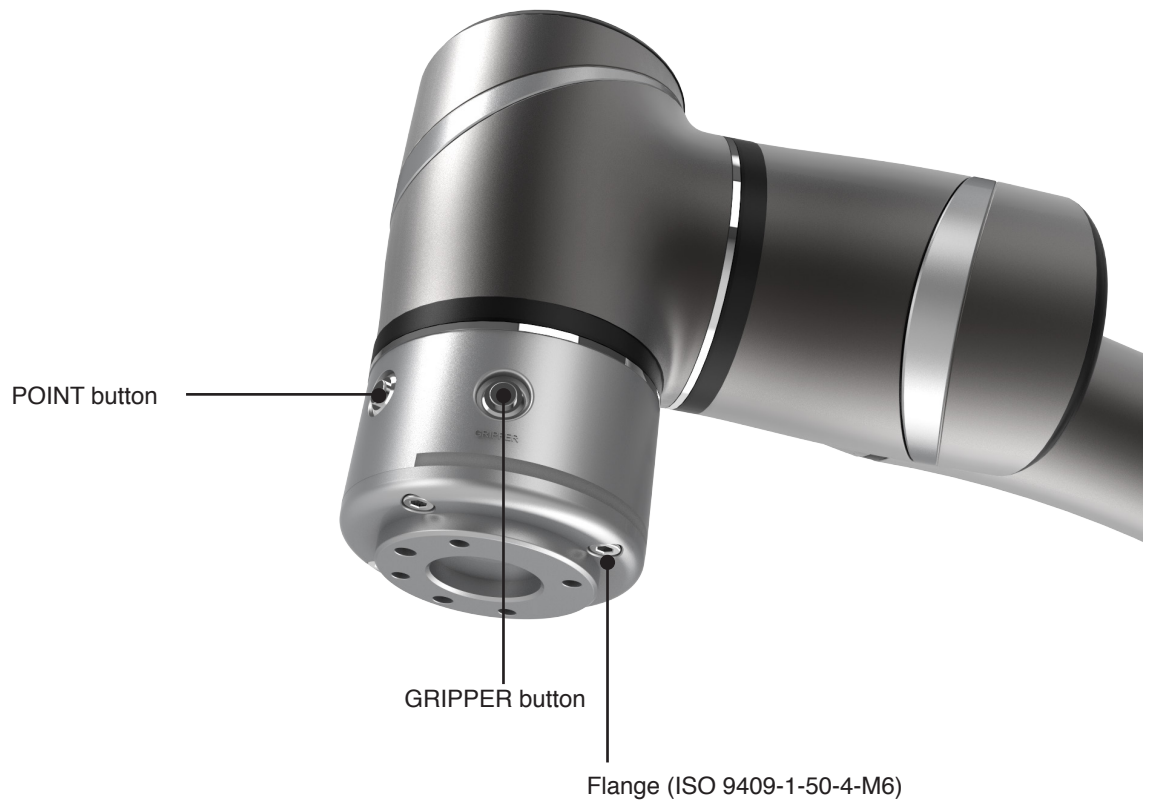

4.2.2.2 End Flange Surface

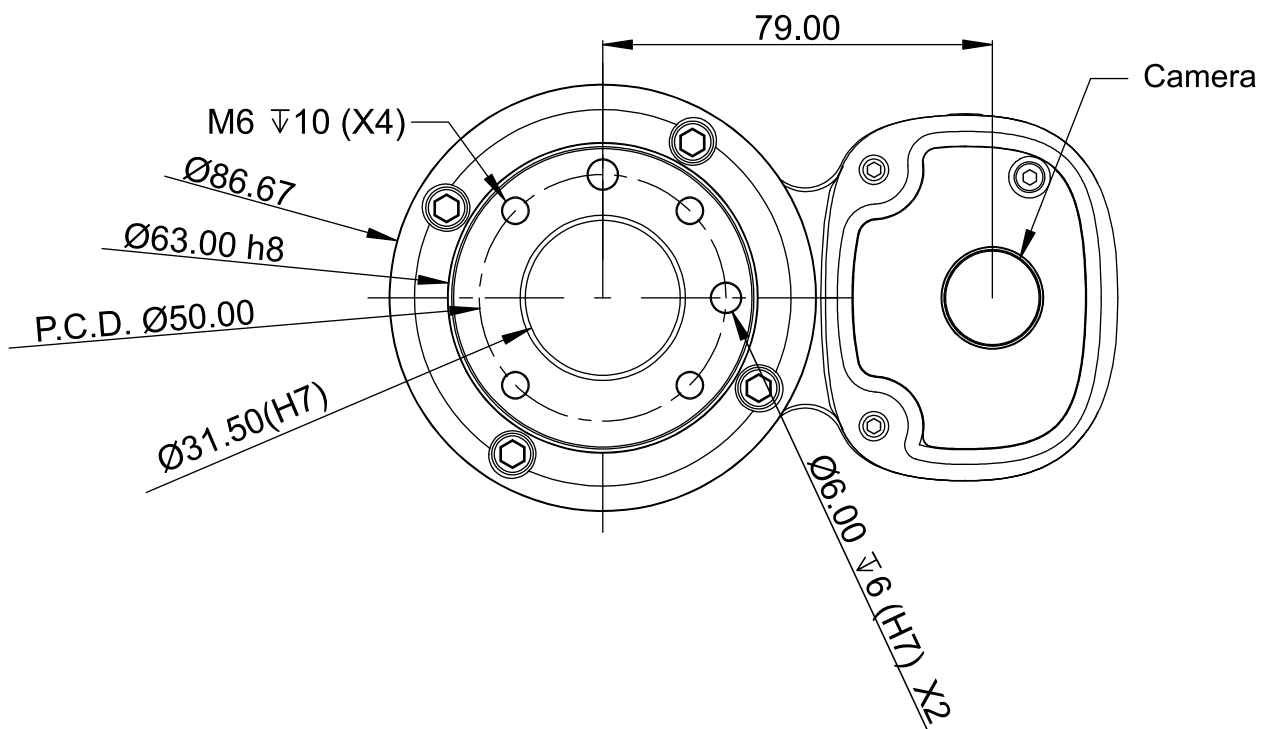
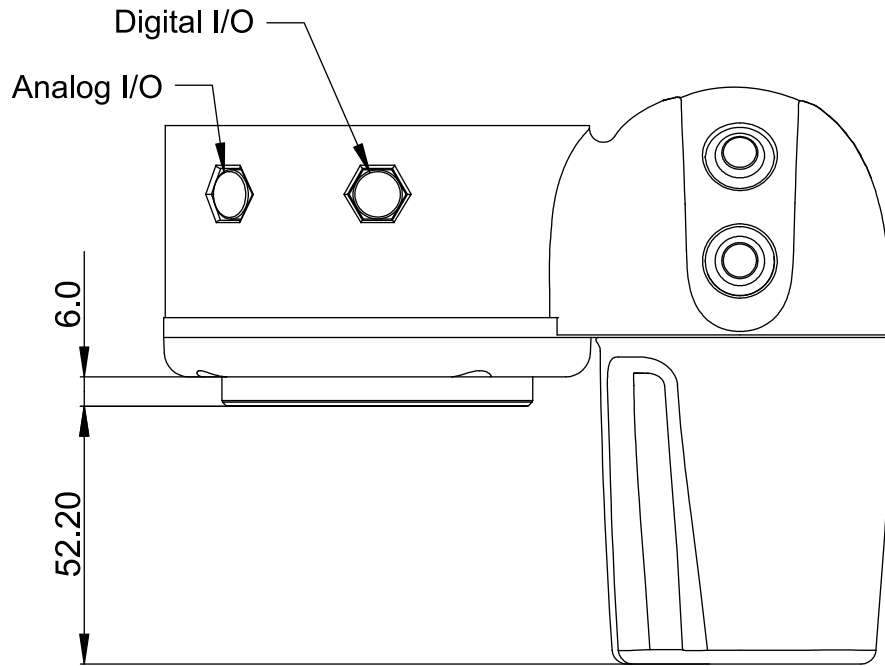

4.2.2.3 End Mounting Caution

The TM5 uses four M6 threaded holes on the end flange and four M6 screws for mounting tools. A tightening torque of 9Nm is recommended. If your application requires higher precision, you can use two positioning pins with a diameter of 6mm for a more secure mounting.



Danger

Tools must be appropriately and securely tightened when using this product. Improper tightening may cause the tool or part to fall out, or even cause personal injury and death.

4.2.2.4 End Indication Light Ring Table

The Indication Light Ring of the TM Robot has several colors which represent different modes and error statuses. Look up the following table which contains troubleshooting methods:

Color/blinking	Description	Troubleshooting
Solid green light	Standby status in Manual Mode (Manual Control mode)	N/A
Flashing green light	Project running in Manual Mode (Trial Run mode)	N/A
Alternating between Green/Red	Manual Mode Error	Press the FREE button to clear the error.
Solid blue light	Standby status in Auto Mode	N/A
Flashing blue light	Project running in Auto Mode	N/A
Alternating between blue and red	Auto Mode Error	After switching to Manual Mode, press the FREE button to clear the error.
Light blue	Safe Startup Mode	Turn on the Emergency button to return to the original mode
Solid red light Buzzer emits a long beep	Fatal error	Shutdown and Restart required

4.2.3 Control Box

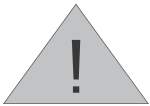

Note

The control box can be placed on the floor or on a rack. Note that 5cm clearance should be left at both sides for air flow.

4.2.3.1 Robot Stick

The Robot Sticks has 6 function buttons, 3 indicator lights, 1 emergency button, and 1 QR-code. There functions are as follow:



Item	Basic Function
Emergency Button	Default emergency button for the robot
Power Button	Bootup (single press)/ Shutdown (long press)
Mode Switch Button	Cycle Manual/Auto Mode (single press). See Section 2.6 for details.
Play/Pause button	Play/Pause Project (press once)
Stop button	Stop Project (press once)
Add/Subtract button	Adjust project speed (press once) under Trial Run mode. See Section 2.6 for details.
Power Indicator	Shows the robot's power status. Not on: Switched off Flashing: Booting Constant:Startup completed
Mode Indicator Lights	The two lights are Manual and Auto. They show the robot's current operating mode. Once bootup is complete only one will always be on.
QR Code Label	Shows the SSID of the robot's own software AP. The content of the SSID is also the robot's name in TCP/IP network.

Some of the function buttons offer the following advanced functions:

Item	Advanced Function
Emergency Button	Hold down before bootup to enter Safe Mode.
Play/Pause button	Play/pause visual calibration operation (press once)
Stop button	Stop visual calibration operation (press once)
Add/Subtract button	<ul style="list-style-type: none"> - Hold to jog the robot at the HMI robot controller page (Hold to Run).See Section 2.7 details. - Lock/ Unlock: hold down both add and subtract until the mode indicator flashes, then follow the sequence "Subtract Add Subtract Subtract Add" when pressing the add/subtract buttons to lock/unlock the Robot Stick (except the Power button)



Note

The robot stick is magnetic so that it can be attached to magnetic surfaces. However, the risk of falling or rotating caused by poor attachment should be taken into account. It is recommended using the official Robot Stick Stand (official accessory) to secure the robot stick. In that case, the Robot Stick Stand should be fixed with screws. Do not freely place the robot stick when it is not fixed. The robot stick should be placed in a way that the signal cables are routed properly to avoid damage caused by pulling.



Danger

1. The control box, cables, power signal cables, and robot stick cannot be used when any of them is in contact with liquids. This may result in personal injury or death.
2. The control box has an IP20 rating so that it cannot be used in environments with powder and moisture. Particular attention should be paid to environments with conductive dust (such as metal swarf).

5. Electrical Interface

5.1 Overview

This chapter introduces all electrical interfaces of the robot arm and control box.

5.2 Electrical Warnings and Cautions

The application design and installation of the robot should comply with the warnings and cautions below.



Danger

1. Ensure all pieces of the equipment are kept dry. If water enters the equipment, disconnect the power and contact your supplier.
2. Only use the original cables included with the robot. If you need longer cables, contact your supplier.
3. Ensure the robot is properly grounded. If the grounding is not correct, it may cause a fire or electric shock.



Warning

The I/O cables used for the link between the control box and other equipment should not be longer than 30 meters, unless testing shows that longer cables are feasible.

5.3 Control Box



Except for USB ports, other interfaces have to be installed while arm is shutdown. Do not install while arm is on to avoid abnormal shutdown.

Front control box configuration

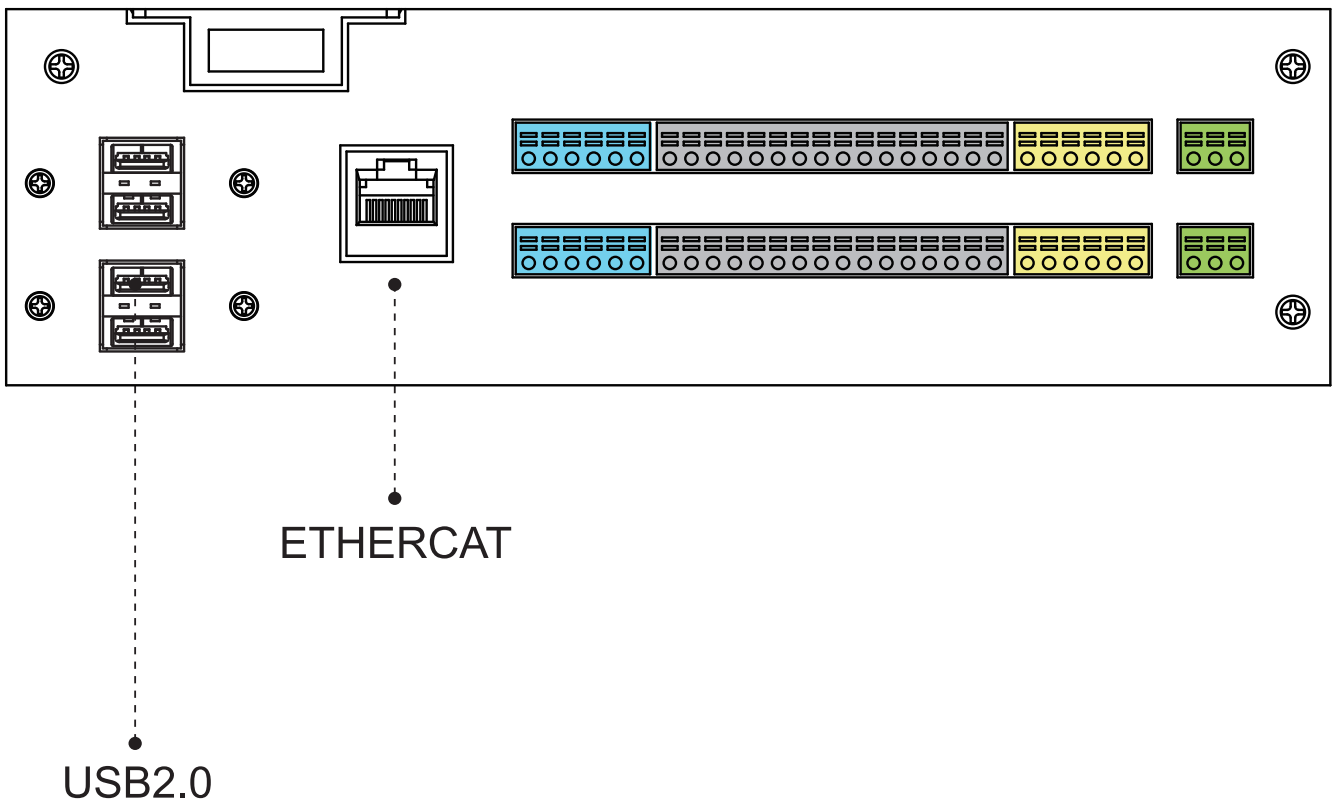

5.3.1 Safety Connector

Provides expansion ports for Emergency Stop(ESTOP) & Safety Stop.

A) ESTOP is a N.C. contact (Normally closed). When ESTOP SW is OPEN,the robot arm enters the Emergency STOP state.

B) Safety A&B is a N.C. contact (Normally closed). When Safety SW is OPEN,the robot arm enters the Pause state.

The factory safety settings are shown below. Operations can be performed without addition of safety devices, as shown below.

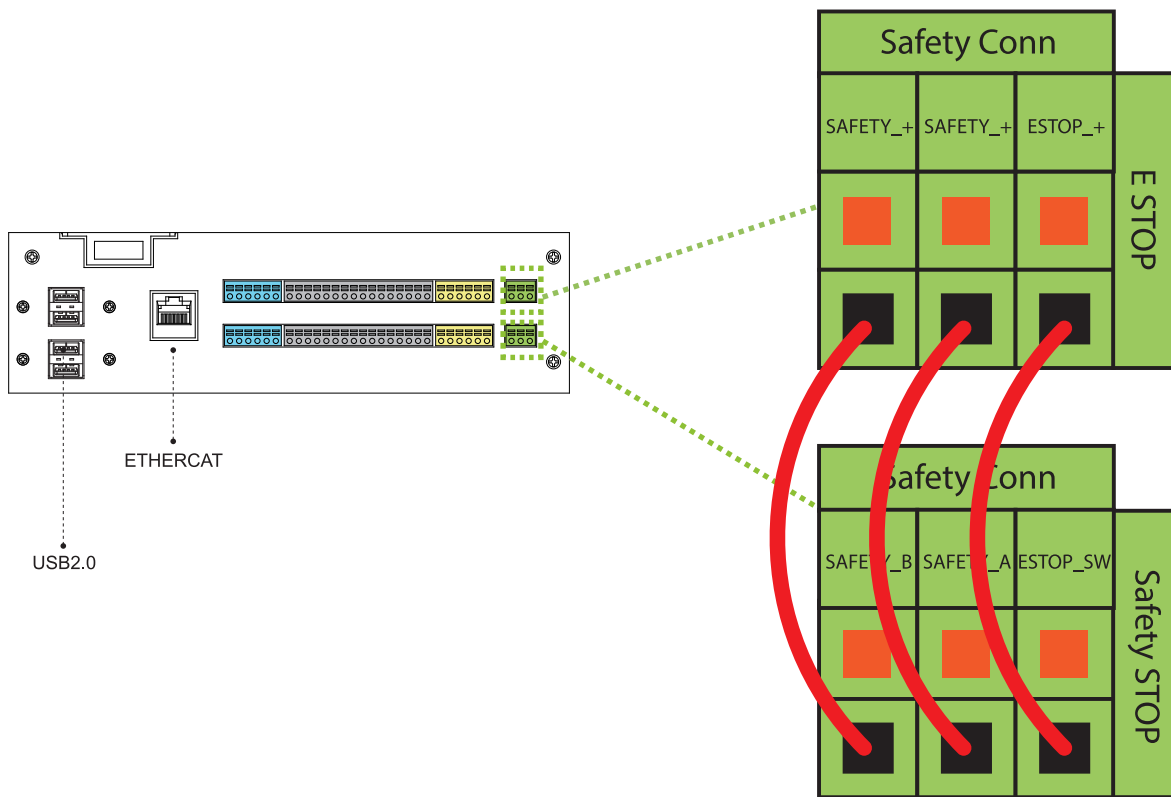

Application settings of the arm safety device

SAFETY & ESTOP SW

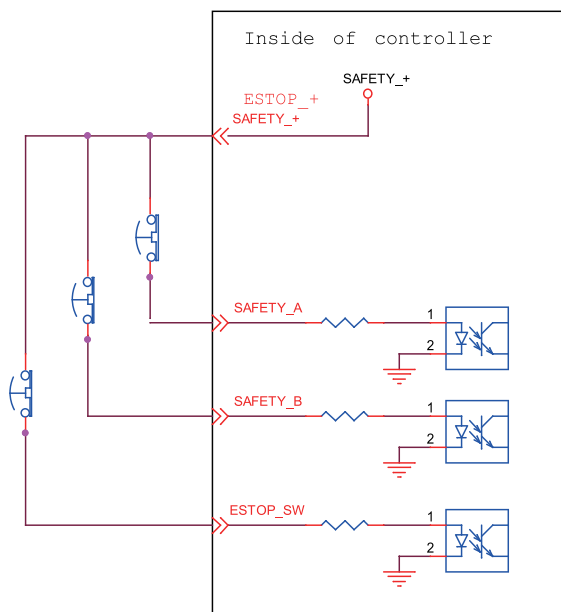

5.3.2 Power Connector

A) During boot, the control box will check for an external 24V input. If none is available then it will switch to the internal 24V supply.

B) The control box itself offers a 24V1.5A output (24_EX). If the 24V load exceeds 1.5A, it enters Safe Mode and disables the 24V output.

C) EX24V provides an external 24V input port. If the load exceeds 1.5A an external power supply can be used instead. The load on EX24V must not exceed 3.5A.

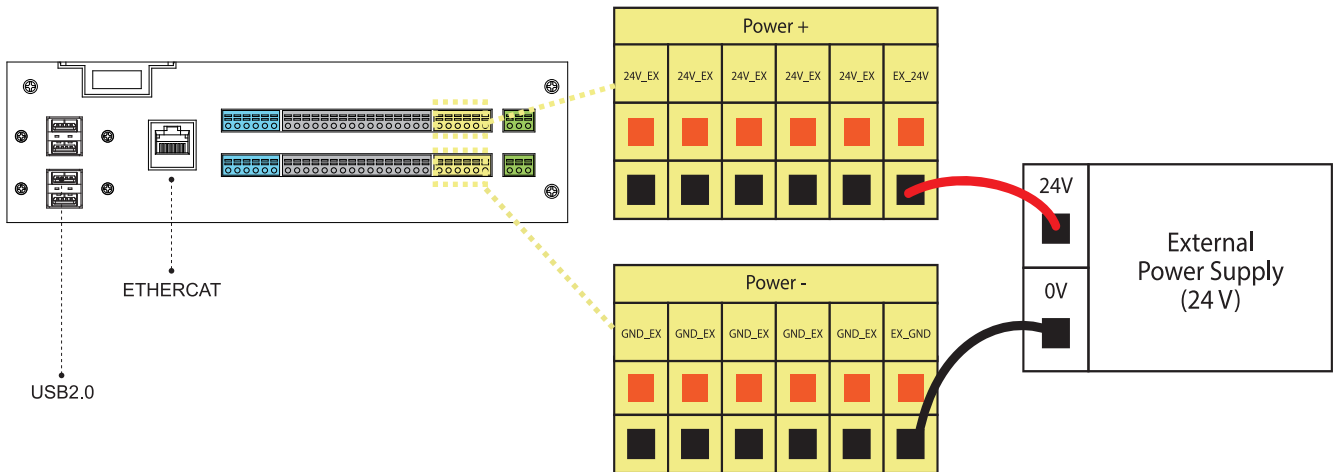

5.3.3 Digital In/Out

Digital In/Out have 16 Channel each, it should be connected as follows,

A) Digital Input: If sensors are connected directly then they should be of the NPN type.

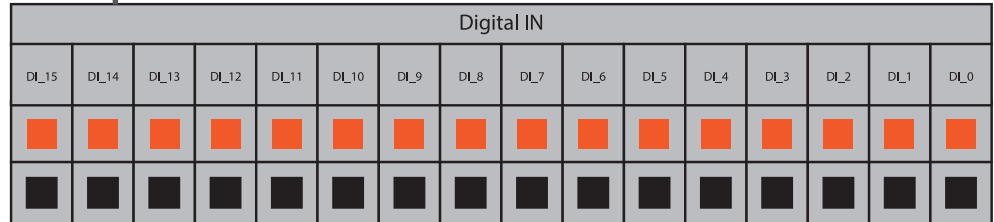
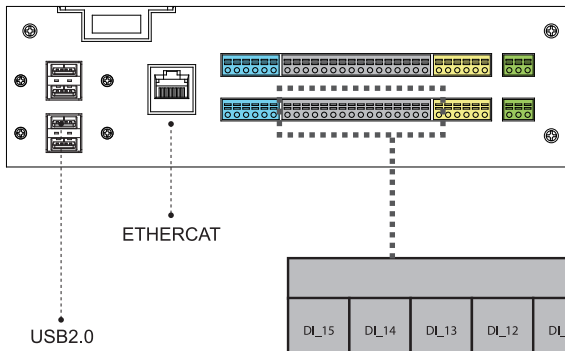

INPUT

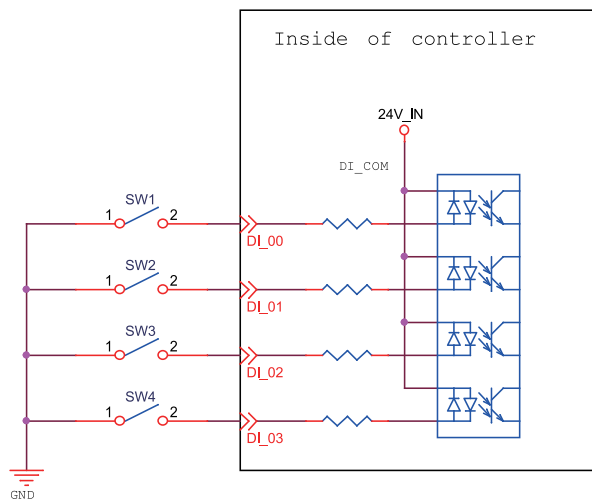

B) Digital Output: The maximum drive current is 100mA per channel. If the load exceeds 100mA, a relay should be used to drive it.

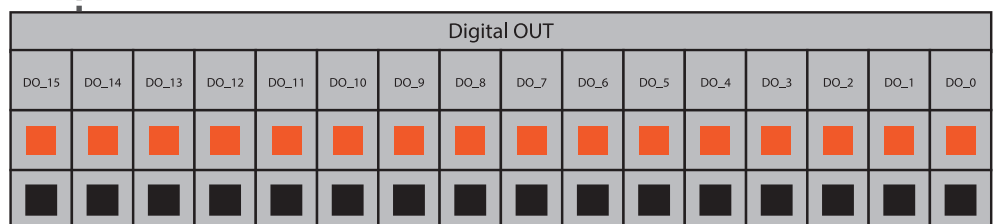
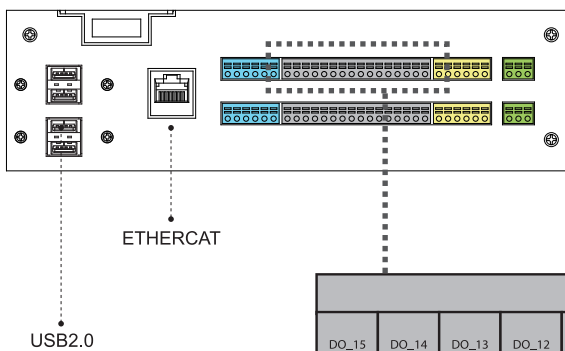

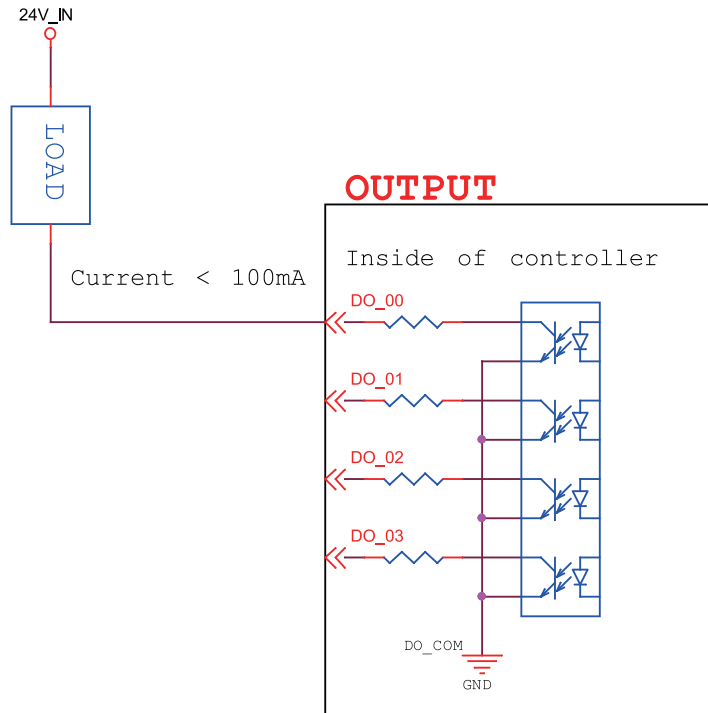

5.3.4 Analog In

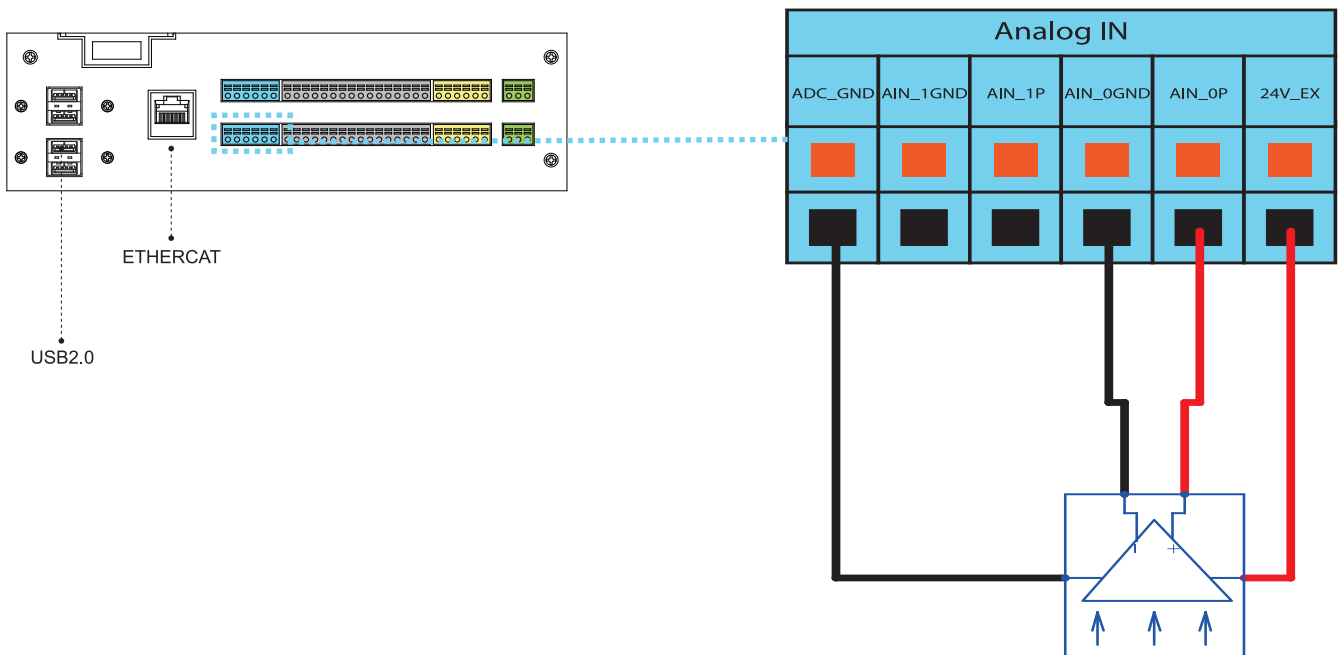

5.3.5 Analog Out

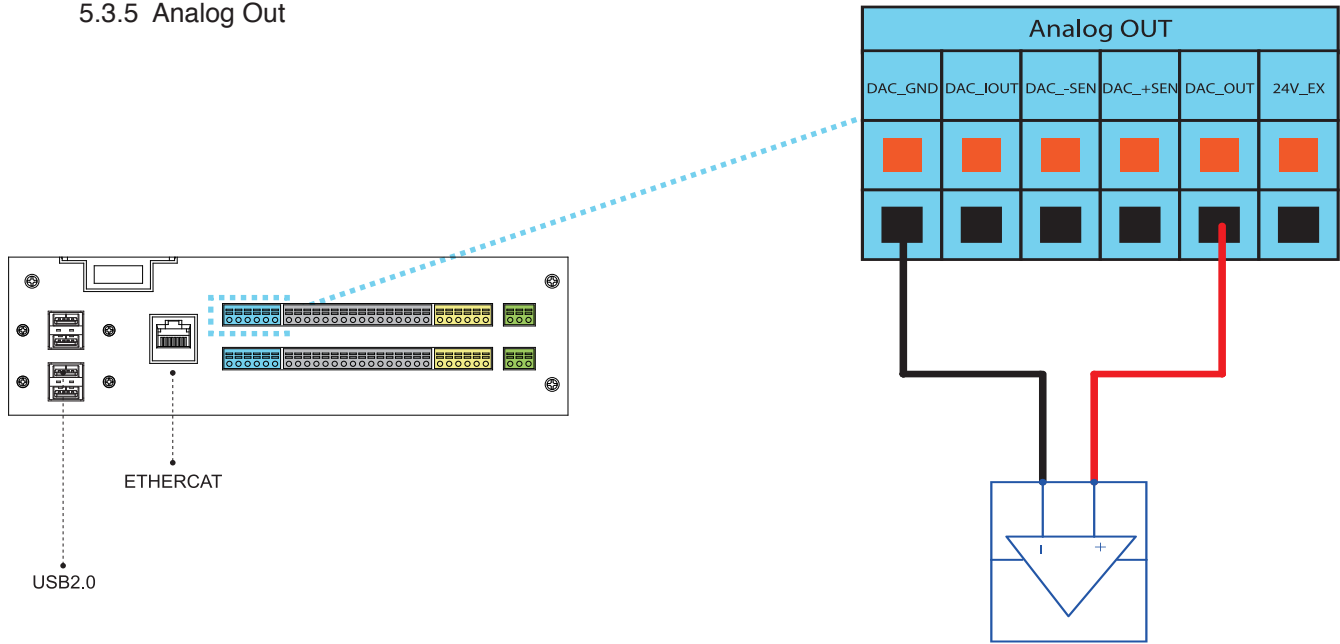

5.3.6 EtherCAT: For EtherCAT Slave I/O Expansion



Robot must be powered off when installing the EtherCAT Slave. Do not plug or unplug the connector while robot is on.

5.3.7 USB Port

The USB port of the control box is used for connecting the keyboard, mouse and external storage devices. External storage devices should only be used for the import/export functions of TM Flow. No USB devices other than those listed above should be connected.

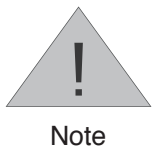

The large differences in the specifications of external storage devices on the market may interfere with high-speed vision transmission while the robot is in operation so do not use your own external storage devices while the robot is running. TM Robot's vision image storage function is a value-added function that can only be used with the dedicated SSD kit sold through the TM Robot website. Interested buyers should contact the TM Robot website.

5.4 Tool End I/O Interface

There are two small connectors on the tool end of the robot: a 8-pin connector and a 5-pin connector.

5.4.1 I/O Terminals

The tool end 24V has a maximum output current 1.5A. If overloading, overload protection is activated and the robot will turn off the 24V output power.

8-pin digital I/O connector

Pin	Wire Color	Pin Define	
1	Brown	+24v	24V output
2	Red	DI_0	Digital Input0
3	Orange	DI_1	Digital Input1
4	Yellow	DI_2	Digital Input2
5	Green	DO_0	Digital Output0
6	Blue	DO_1	Digital Output1
7	Purple	DO_2	Digital Output2
8	Black	+0V	+0v

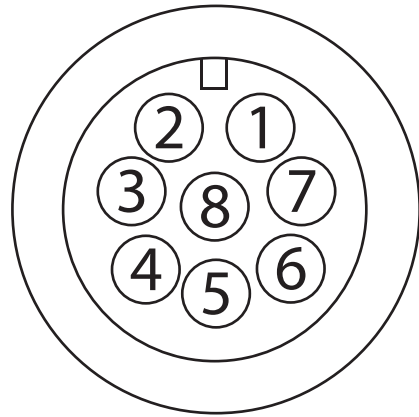

5-pin analog I/O connector

Pin	Wire Color	Pin Define	
1	Black	AI Analog	Input
2	Brown	RSV	Reserve
3	Red	RSV	Reserve
4	Orange	GND	GND
5	Yellow	GND	GND

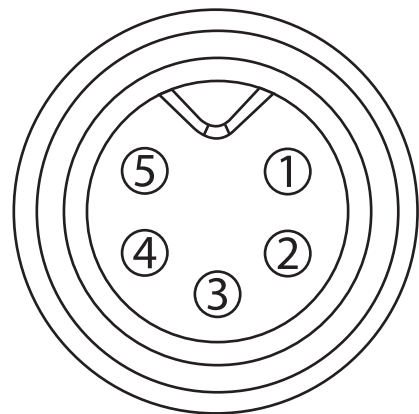

5.4.2 Connecting Tool End Digital Out

The following figure shows how to connect the tool end digital output:

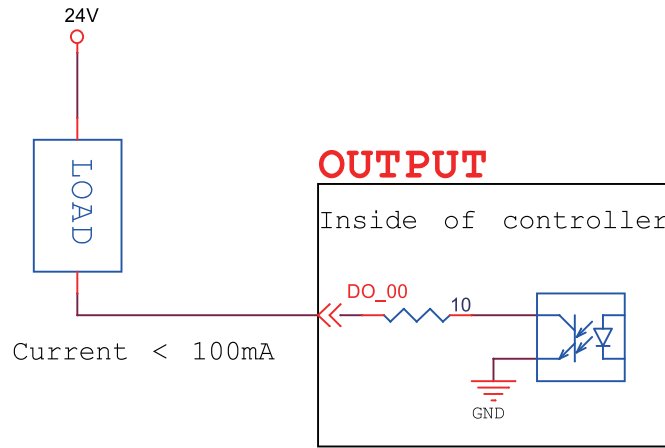

5.4.3 Connecting Tool End Digital In

The following figure shows how to connect the tool end digital input:

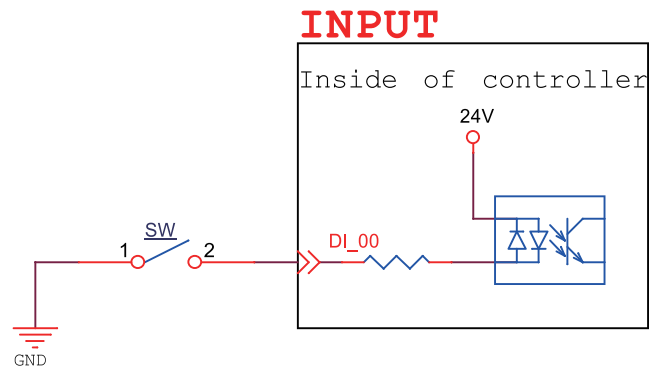

5.4.4 Connecting Tool End Analog In

The following figure shows how to connect the tool end Analog input:

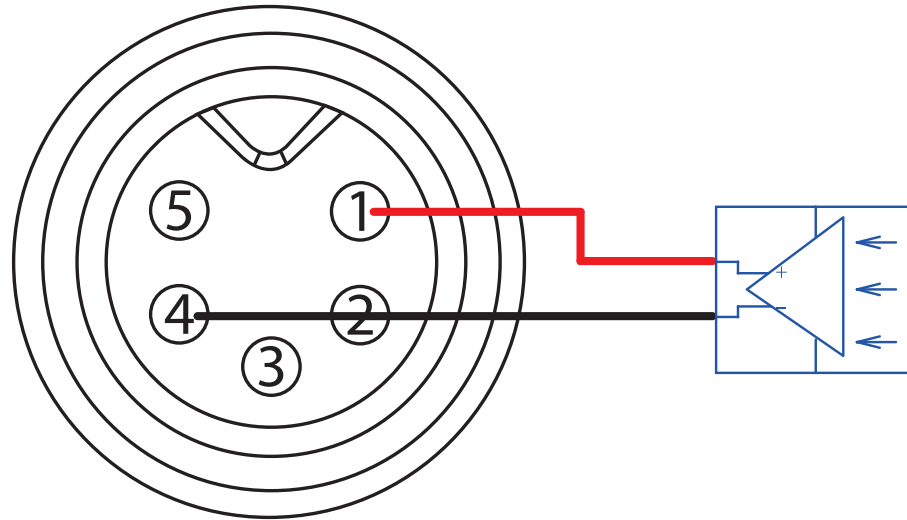

5.5 Control Box Interfaces

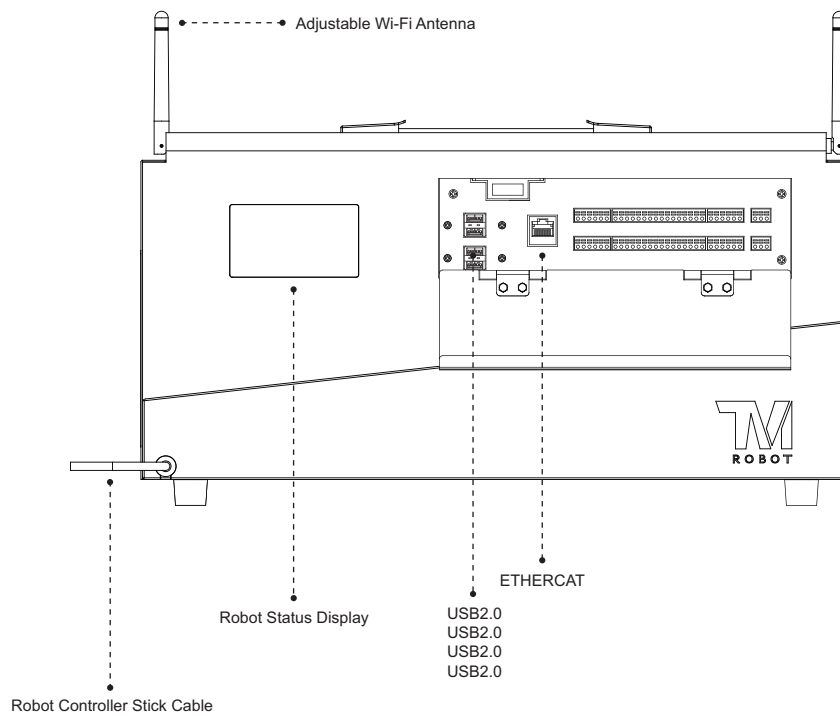



Note

The ETHERCAT interface can only be used to connect ETHERCAT devices. Improper connection may cause stopping of the robot.

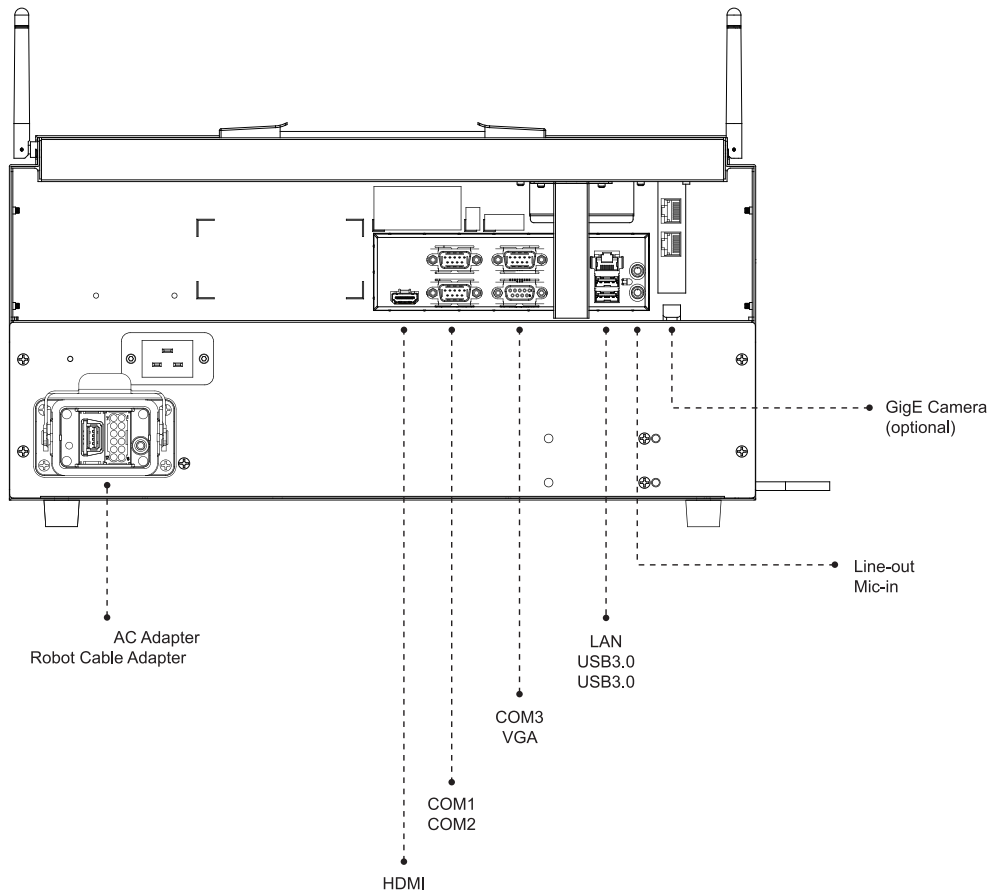

5.6 Control Box Power Interface and Robot Interface

5.6.1 Control Box Power Interface

The power cable of the control box has an IEC plug. The local power plug is connected to the IEC plug.

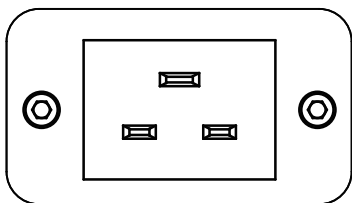

The power supply should be equipped with the following devices:

- Grounding
- Main fuse
- Residual current device (RCD)

It is recommended to install a main switch on the equipment power supply for robot applications for servicing and inspection purpose.

The table below shows the electrical specifications:

Parameters	Minimum value	Typical value	Maximum value	Unit
Input voltage	100	-	240	VAC
External mains fuse (100V~120V)	-	-	15	A
External mains fuse (200V~240V)	-	-	8	A
Input frequency	43	-	63	Hz



Danger

1. Ensure that the robot is correctly grounded (electrical grounding).
2. Ensure that the input current of the control box is protected by the Residual Current Device (RCD) and appropriate fuses.
3. Ensure that all cables are correctly connected before the control box is energized. Always use genuine power cables correctly.

5.6.2 Robot Interface

The following figure shows the connection interface of the robot. The cables of the robot are connected to the control box through the interface.

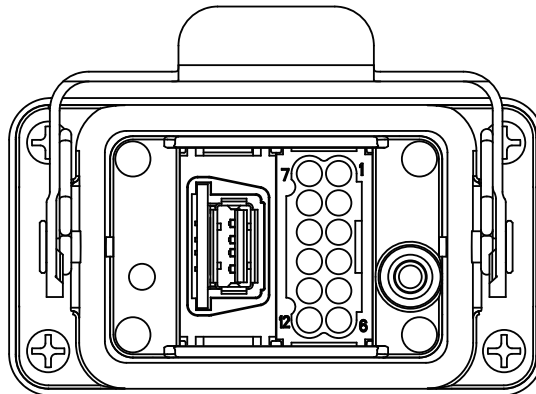

Warning

1. When the robot is turned on, do not disconnect cables of the robot. When cables of the robot are not connected to the connection interface, do not turn on the robot.
2. Do not extend or modify the original cables of the robot.

6. Maintenance and Repair

Maintenance of Techman Robot: Clean the exterior of the Techman Robot periodically, and keep the moving joints clean. The filter of the control box must be cleaned or replaced periodically (determine how often the filter is cleaned or replaced depending on the cleanliness of surroundings).

Only the legal distributor or authorized service center should repair the Techman Robot. The user should not repair it himself or herself.



Danger

When the robot finishes a job and enters maintenance or servicing status, the user should record the details of each setting for the job; after repairing and installing it to the work position, the user must make sure that each setting satisfies the original conditions before resuming working status, including but not limited to:

- Safety Software Settings
- Safety I/O
- Preset operation project
- TCP Settings
- I/O Settings
- I/O Wiring

7. Warranty Statement

7.1 Product Warranty

The user (customer) may make a request to his/her dealer and retailer within any reasonable situation. The manufacturer will provide warranty under the following conditions:

During the first twelve months of the warranty period (no more than 15 months from the date of shipment), Techman Robot will provide necessary spares for malfunctioned parts of new equipment due to production and manufacture error or damage. If the user (customer) has to bear labor costs, a new or refurbished part can be used for servicing. If equipment defects are caused by improper handling or failure to comply with manual requirements, this guarantee is invalid. Warranty services do not cover operations conducted by the dealer or user, such as arm installation, software download. Your warranty request must be made two months before the warranty is expired. All replaced or returned items are the property of Techman Robot. This warranty does not cover other requests directly or indirectly related to equipment. No conditions of this warranty shall attempt to limit or exclude customer's statutory rights or manufacturer's responsibility for personal injury or death due to negligence. The warranty cannot be extended, even if it is the initial warranty. Techman Robot reserves the right to charge customers for replacement or service costs, as long as no warranty terms are violated.

The above-mentioned rules shall not imply a change in the burden of proof to the detriment of the interests of customers. When equipment becomes defective, we are not liable for compensation for any indirect, incidental, special, or corresponding damage, including but not limited to profit loss, loss of use, production loss or other production equipment damage.

7.2 Disclaimer

Techman Robot will continuously improve the reliability and performance of the product. Therefore, we reserve the right to upgrade the product without prior notice. Techman Robot has verified the accuracy and correctness of this Manual, but will not liable for any erroneous or omitted information.

Appendix A. Stop Time and Distance

Stop Time and Distance Table

		Axis 1		Axis 2		Axis 3	
Load (kg)	Axis speed (°/sec)	Stop time (ms)	Stop distance (°)	Stop time (ms)	Stop distance (°)	Stop time (ms)	Stop distance (°)
2	36	600.44	6.912	600	7.25	598.78	7.238
	72	601.3	13.764	600.52	14.042	601.08	14.22
	108	598.794	20.61	600.2	21.034	599.98	21.244
	144	593.07	27.438	597.56	27.876	600.68	27.95
	180	594.94	33.28	600.84	34.006	598.36	34.95
4	36	602.25	6.86	598.82	7.148	600.16	7.114
	72	600.31	13.71	600.04	14.222	600.5	14.27
	108	600.55	20.51	600.02	21.012	600.74	21.076
	144	601.08	27.346	601.3	27.862	598.96	28.082
	180	594.44	33.834	598.82	34.972	601.72	34.976
6	36	600.14	6.83	598.976	7.194	599.56	7.162
	72	599.64	13.616	598.3	14.19	601.68	14.186
	108	599.98	20.526	598.7	21.034	599.24	20.962
	144	600.48	26.766	600.04	27.76	599.68	27.98
	180	598.09	33.986	600.68	34.892	600.76	35.044

Appendix B. Technical Specifications

Technical Specifications

Model		TM5-700	TM5-900	TM5X-700	TM5X-900
Weight		22kg	22.2kg	21.7kg	21.9kg
Payload		6kg	4kg	6kg	4kg
Reach		700mm	900mm	700mm	900mm
Joint ranges:	J1:	+/- 270°			
	J2,J4,J5:	+/- 180°			
	J3:	+/- 155°			
	J6:	+/- 270°			
Speed:	J1~J3:	180°/s.			
	J4~J6:	225°/s.			
Repeatability		+/- 0.05 mm			
Degrees of freedom		6 rotating joints			
I/O ports:		Digital in Digital out Analog in Analog out	Control box 16 16 2 1	Tool conn. 3 3 1 0	
I/O power supply		24V 1.5A for control box and 24V 1.5A for tool			
IP classification		IP54(Arm)			
Power consumption		Max. 1300 watts			
Temperature		The robot can work in a temperature range of 0-40°C			
Power supply		100-240 VAC, 50-60 Hz			
I/O Interface of Control Box		3xCOM, 1xHDMI, 1xEtherCAT, 2xGigE, 1xLAN, 4xUSB2.0, 2xUSB3.0, 1xVGA			
Robot Vision					
Eye in Hand (Built in)		1.2M/5M pixels, color camera		N/A	
Eye to Hand (Optional)		Support Maximum 2 GigE cameras			

