

Tether - 3 pins 48V, 3 pins GND, 2 pins for data
48V from boat to ROV.

Motor reference (magnetic switch)

48V to 12V conversion inside the ROV

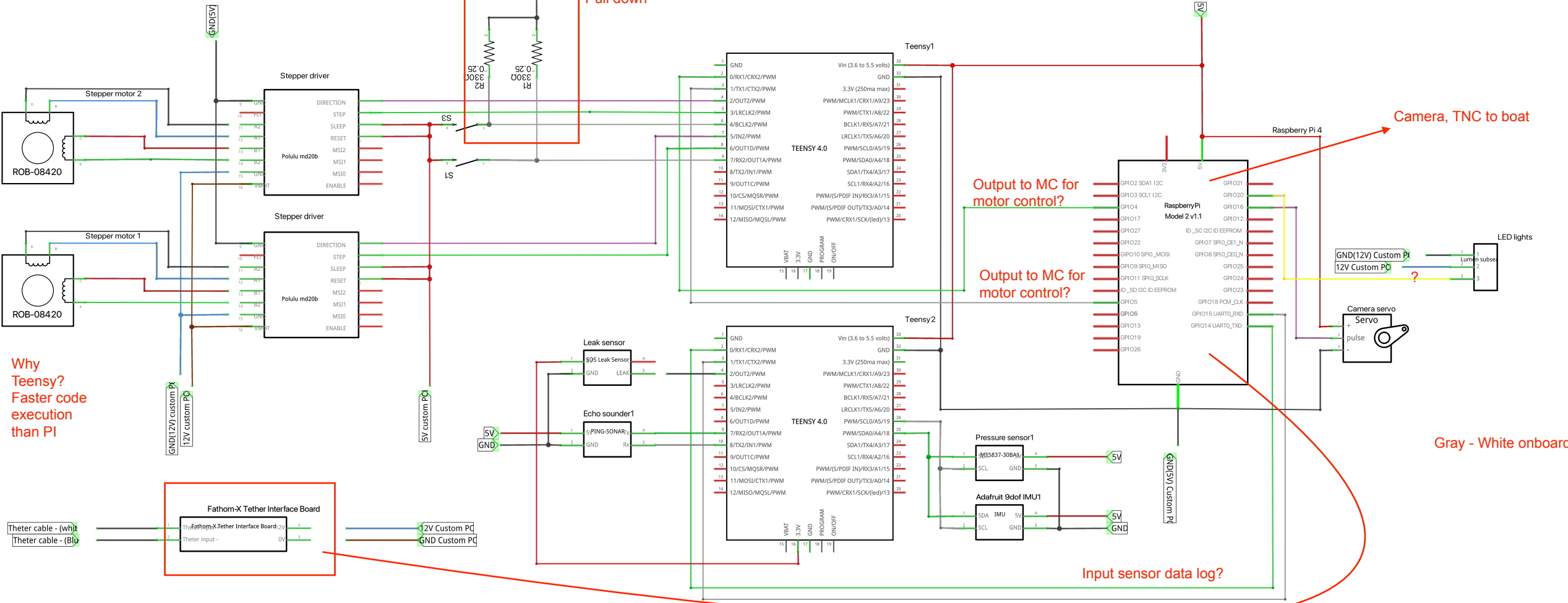

Why Teensy?
Faster code execution than PI

Output to MC for motor control?

Output to MC for motor control?

Camera, TNC to boat

Gray - White onboard

Input sensor data log?