

Installation and User Guide

English

Objet WaterJet



Copyright

Copyright © 2012 Stratasys Ltd. All rights reserved.

This documentation contains proprietary information of Stratasys Ltd. This information is supplied solely to assist authorized users of this Stratasys 3-D printing system. No part of this document may be used for other purposes, and it may not be disclosed to other parties.

The specifications on which this document is based are subject to change without notice.

No part of this book may be reproduced in any form or by any means, nor stored in a database or retrieval system, without prior permission in writing from Stratasys Ltd.

If this document is distributed as a PDF file, you may print it for internal use.

Trademarks

The following are registered trademarks of Stratasys Ltd.: Stratasys®, Objet®, FullCure®.

Microsoft and Windows are trademarks of Microsoft Corporation.

All names of products and services cited in this book are trademarks or registered trademarks of their respective companies.

Equipment Recycling



In the European Union, this symbol indicates that when the last user wishes to discard a product, it must be sent to appropriate facilities for recovery and recycling. For information about proper disposal, check your purchase contract, or contact the supplier of the equipment.

Limitation of Liability

The product, software or services are being provided on an “as is” and “as available” basis. Except as may be stated specifically in your contract, Stratasys Ltd. expressly disclaims all warranties of any kind, whether express or implied, including, but not limited to, any implied warranties of merchantability, fitness for a particular purpose and non-infringement.

You understand and agree that Stratasys Ltd. shall not be liable for any direct, indirect, incidental, special, consequential or exemplary damages, including but not limited to, damages for loss of profits, goodwill, use, data or other intangible losses (even if Stratasys has been advised of the possibility of such damages), resulting from: (i) the use or the inability to use the product or software; (ii) the cost of procurement of substitute goods and services resulting from any products, goods, data, software, information or services purchased; (iii) unauthorized access to or alteration of your products, software or data; (iv) statements or conduct of any third party; (v) any other matter relating to the product, software, or services.

The text and drawings herein are for illustration and reference only. The specifications on which they are based are subject to change. Stratasys Ltd. may, at any time and without notice, make changes to this document. Stratasys Ltd., for itself and on behalf of its subsidiaries, assumes no liability for technical or editorial errors or omissions made herein, and shall not be liable for incidental, consequential, indirect, or special damages, including, without limitation, loss of use, loss or alteration of data, delays, or lost profits or savings arising from the use of this document.

DOC-01201 Rev. A
September 2012

Contents

1	Introduction	
	Objet WaterJet	1-2
	For More Information.....	1-2
	Terms Used in This Guide.....	1-2
2	Safety	
	Safety Guidelines	2-2
	First Aid for Working With Printing Materials.....	2-3
	Contact with Skin.....	2-3
	Contact with Eyes	2-3
	Ingestion.....	2-3
	Inhalation	2-3
	Waste Disposal.....	2-4
3	Overview	
	Configuration	3-2
	Size and Weight	3-3
	Capacity.....	3-5
	On/Off Switch.....	3-5
	Electrical Outlets	3-5
	Cover Latches	3-6
	Nozzle Selection and Flow Regulation.....	3-7
	Foot Pedal	3-8
	Waste Filter	3-8
	Water Inlet	3-8
4	Installation	
	Configuring the WaterJet Stand	4-2
	Attaching the Feet to the Base.....	4-2
	Assembling the Table Stand.....	4-3
	Assembling the Floor Stand	4-4
	Leveling the WaterJet Unit	4-6
	WaterJet Connections.....	4-7
	Connecting the Water Supply	4-7
	Connecting the Drain Hose	4-9
	Connecting the Power Cables	4-9
5	Cleaning Models	
	Cleaning Process.....	5-2
	Removing Excess Support Material by Hand.....	5-2
	Removing Support Material with the WaterJet.....	5-2
	Jet Nozzle	5-2
	Spray Nozzle.....	5-2
	Operating the WaterJet	5-3
	Removing Support Material with Sodium Hydroxide	5-4
6	Maintenance	
	Replacing a Lamp	6-2
	Replacing the Wiper Fuse.....	6-4

Maintaining the Water Pressure Pump	6-5
Maintenance	6-5
Troubleshooting.....	6-5
7 WaterJet Replacement Parts	
WaterJet Replacement Parts	7-2

1

Introduction

Objet WaterJet	1-2
For More Information	1-2
Terms Used in This Guide.....	1-2

Objet WaterJet

The Objet WaterJet provides easy and fast cleaning of support material from models printed on Stratasys 3-D printing systems. The WaterJet comes equipped with two types of nozzles, enabling you to choose the flow rate and pressure suitable for cleaning, both delicate and robust models.

This user guide provides instructions for installing, operating and maintaining the following systems:

- OBJ-01200—Objet WaterJet (110–120-volt)
- OBJ-01201—Objet WaterJet(220–240-volt)
- OBJ-01202—Objet WaterJet (100-volt)

For More Information

Visit <http://www.stratasys.com> for information on Stratasys, its technologies, products, and application methods.

If you have any questions about the information presented in this document, or if you have any comments or suggestions for future editions, please send a message to c-support@stratasys.com.

Terms Used in This Guide

resin	The base substance from which photopolymer printing materials are made for use in Stratasys printers.
Model material	Material used for building models.
Support material	Material used for supporting the structure of models during production. This material is later removed with the WaterJet.
jet nozzle	High-pressure nozzle for removing support material.
Spray nozzle	Medium-pressure nozzle for removing support material.

2

Safety

Safety Guidelines.....	2-2
First Aid for Working With Printing Materials.....	2-3
Contact with Skin.....	2-3
Contact with Eyes.....	2-3
Ingestion.....	2-3
Inhalation.....	2-3
Waste Disposal.....	2-4

Safety Guidelines

The following general guidelines, together with the instructions provided throughout this user guide, ensure user safety while operating and maintaining the WaterJet system. **If the system is not operated as specified, the user's safety may be compromised.**

- Installation and removal of the WaterJet system should only be done by qualified service personnel.
- Service operations should be performed only by personnel who have been instructed in safety relevant precautions.
- All personnel operating or maintaining the WaterJet system should know the location of first aid and emergency equipment and how to use them. **Never block access to this equipment!**
- Read and follow safety and maintenance instructions that come with the pressure pump.
- Do **not** direct the pressurized stream of water at people, animals, or objects.
- Check the WaterJet hoses before each cleaning session. Do **not** operate the WaterJet if a hose is damaged or crimped.
- Never operate the WaterJet while the cabinet cover is open.
- Wear earplugs for protection against loud noise.
- The power cable should be connected at an easily accessible outlet near the WaterJet.
- The wall outlet must be protected by a residual current device (RCD)—ground current leakage detector —that protects from a leakage of more than 30 mA.
- Never connect the power plug to an outlet that does not have a ground (earth) wire, and never disconnect the ground. Doing so may expose the operator to serious danger from electric shock.
- Do **not** change the power plug at the end of the water pressure pump power cable.
- Always connect the water pressure pump power cable to the universal power outlet at the back of the WaterJet unit.
- Protect electrical connections from contact with water spray and moisture.
- Never insert screwdrivers, wires, or other objects into the pump or power supply housing.
- Several parts of the WaterJet can remain extremely hot after use. Avoid touching the main power supply, the wiper motor, the pressure pump and the lamps until they have cooled.
- Notify co-workers and those who have access to the WaterJet system before beginning non-routine and hazardous work.
- Report any potential dangers and safety-related accidents to your safety officer or to other appropriate authorities.

First Aid for Working With Printing Materials

In general, try to avoid direct contact with uncured printing material. If skin or eyes come into contact with it, wash the area immediately and thoroughly with water, and follow the first-aid instructions below.

Contact with Skin

If uncured printing material comes in contact with skin, wash the affected area immediately and thoroughly with soap and cool water, then remove contaminated clothing. Pay particular attention to flushing the hair, ears, nose and other parts of the body that are not easily cleaned.

- Use cool water to prevent skin pores from opening, so that the liquid material does not easily penetrate the skin.
- Do not use solvents to clean skin.
- If large areas of skin have been exposed, or if prolonged contact results in blisters, seek medical attention. In any case, if irritation persists, seek medical attention.
- Avoid the accidental transfer of printing material from the hands to other areas of the body, especially to the eyes.
- If protective cream was used, do not reapply it until the skin has been completely cleansed.

Contact with Eyes

If uncured printing material comes in contact with the eyes, flush immediately with large amounts of water for 15 minutes and seek medical attention.

- Avoid sunlight, fluorescent light, and other sources of ultraviolet radiation.

The wearing of contact lenses when handling liquid printing materials is not recommended. If the liquid splashes into the eyes when contact lenses are worn, immediately remove the lenses and flush the eyes with water.

- Clean and disinfect the contaminated lenses.
- Do not wear contact lenses until eye irritation disappears.

Ingestion

If printing material is swallowed, refer to the instructions included with the cartridge. *Seek medical attention immediately.*

Inhalation

Vapors from printing materials can be irritating to the respiratory system. If respiratory irritation occurs, expose the victim to fresh air immediately.

- If the victim has stopped breathing, perform artificial respiration or cardiopulmonary resuscitation.
- Seek medical attention immediately.
- Keep the patient warm but not hot.
- Never feed anything by mouth to an unconscious person.
- Oxygen should be administered by authorized personnel only.

Waste Disposal

Fully cured models present no special safety or health-related issues. However, check if local regulations regard cured and partially cured resins as hazardous industrial waste, and comply with all applicable regulations governing their disposal.

Overview

Configuration.....	3-2
Size and Weight	3-3
On/Off Switch	3-5
Electrical Outlets.....	3-5
Nozzle Selection and Flow Regulation	3-7
Foot Pedal	3-8
Waste Filter.....	3-8
Water Inlet	3-8

Configuration

The WaterJet system consists of the following main components:

- a. WaterJet unit (cabinet and stand)
- b. water pressure pump
- c. metal base
- d. stand extensions

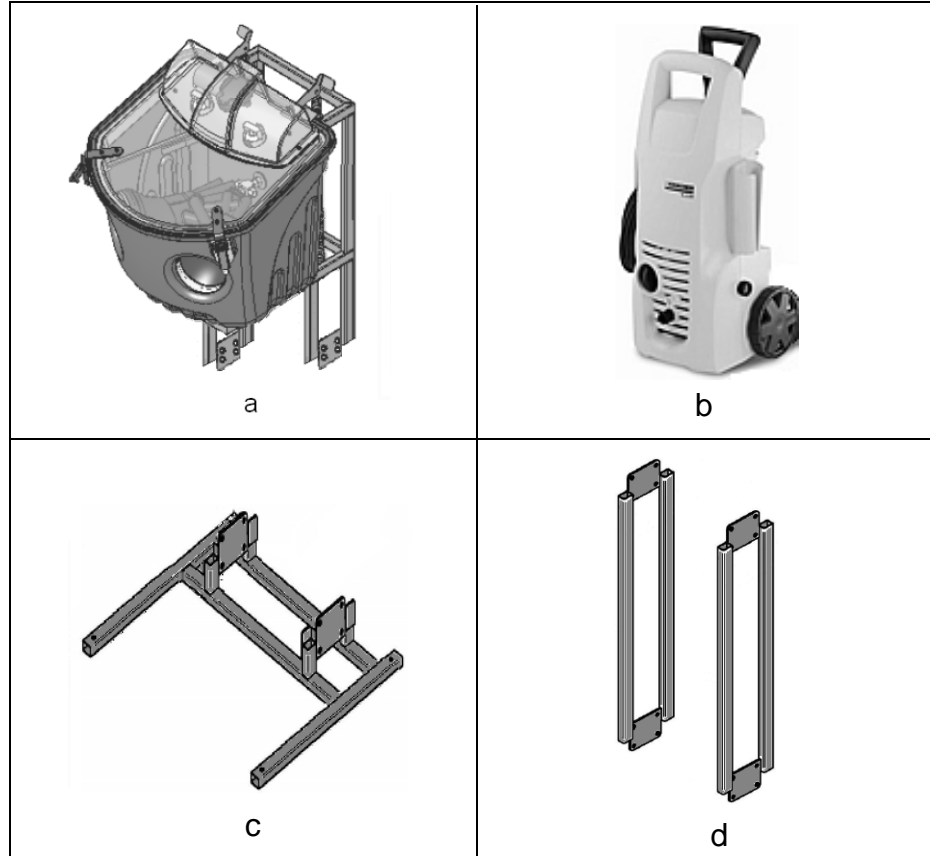

Figure 3-1: WaterJet system components

Note: The water pressure pump supplied with the WaterJet may differ from the water pressure pump shown above.

You can configure the WaterJet unit to stand on the floor, or to sit on table by adding or removing the stand extensions.

Size and Weight

The following table lists the size and weight of the WaterJet unit and water pressure pumps.

Unit		W × H × D (cm)	W × H × D (in.)	Weight
WaterJet with table stand		58 × 75 × 70	22.8 × 29.5 × 27.5	25.6 kg / 56.3 lb
WaterJet with floor stand		58 × 155 × 70	22.8 × 61 × 27.5	30 kg / 66 lb
Water Pressure Pump	220-240 V	29.5 × 55.6 × 24	11.6 × 21.9 × 9.4	9 kg / 19.8 lb
	110-120 V	31.8 × 57.2 × 22.9	12.5 × 22.5 × 9	7 kg / 15.4 lb
	100 V	22.9 × 58.4 × 35.6	9 × 23 × 14	7.3 kg / 16 lb

Table 1: WaterJet and water-pressure-pump dimensions and weights



When its cover is open, the effective height of the WaterJet unit increases by 25 cm (9.8 inches).

The following figure shows the WaterJet unit installed on a table.

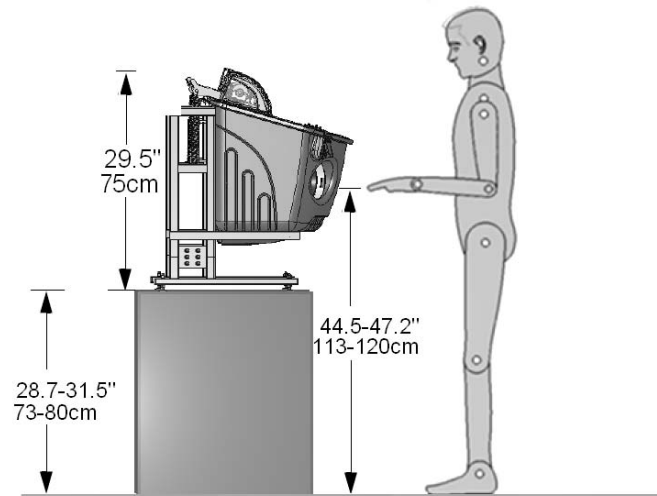

Figure 3-2: Dimensions of the WaterJet unit installed on a table

The following figure shows the WaterJet unit installed on the floor.

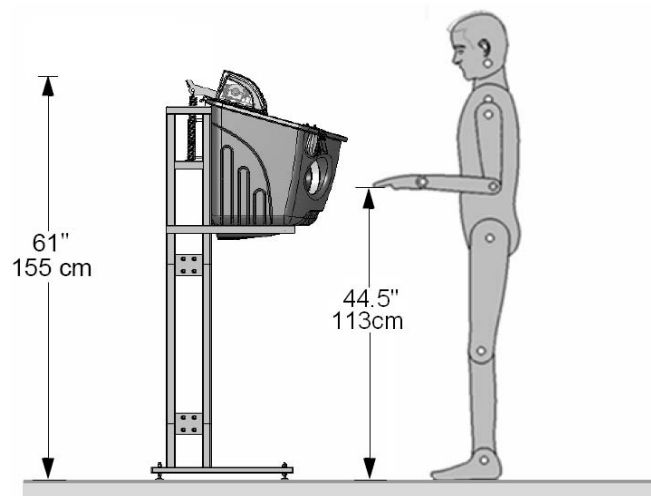

Figure 3-3: Dimensions of the WaterJet unit installed with stand extensions

Capacity

The Objet WaterJet can clean models that have the following maximum dimensions:

W × H × D (cm)	W × H × D (in.)
30 × 25 × 20	11.8 × 9.8 × 7.9

Table 2: Maximum model size

On/Off Switch

The WaterJet unit has a power switch on the electrical box, located on the back of the WaterJet unit. Use this switch to turn the WaterJet on and off. Leave the water pressure pump on/off switch on at all times, to enable the switch on the WaterJet unit to control the pump as well.

The switch at the back of the WaterJet cabinet turns the WaterJet on and off. The lamps inside the WaterJet cabinet light when the WaterJet is switched on (see figure 3-4).

- Turn off the WaterJet.
- Close the water supply
- **Important:** Make sure to open the water supply to the water pressure pump before using the WaterJet again.



If the pressure pump has its own power switch, leave it in the ON position, so that it will be controlled by the power switch on the WaterJet unit.

Electrical Outlets

The Waterjet is equipped with two electrical outlets at the back of the WaterJet cabinet.

- a universal power outlet
The power cable from water pressure pump connects to the outlet at the back of the WaterJet.
- an IEC 320 C14 power outlet
The IEC 320 power cable connects between the WaterJet unit and the wall outlet.

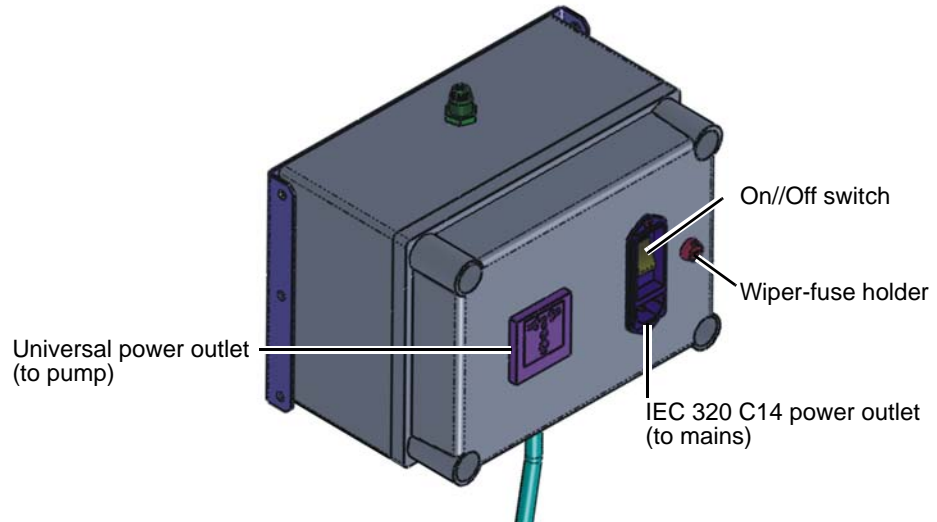

Figure 3-4: Power control box at the back of the WaterJet



WARNING: Electrical Hazard. Leakage currents could cause serious electrical shock. Make sure that the wall outlet conforms with the requirements specified in the Site Preparation Guide.

Cover Latches

Two latches on the front of the WaterJet unit lock the cover.

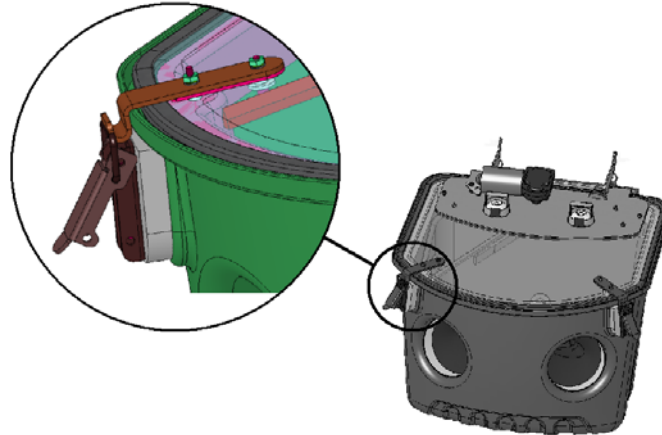

Figure 3-5: WaterJet locking latches



WARNING: High water pressure. Lock the WaterJet unit cover before operating it.

Nozzle Selection and Flow Regulation

You select which nozzle to use by turning nozzle selector valve. For example, in figure 3-6, when the selector points to the right, the spray nozzle is used.

The flow regulator allows you to increase or reduce the water flow. It is available in some models only and can be ordered as a spare part.

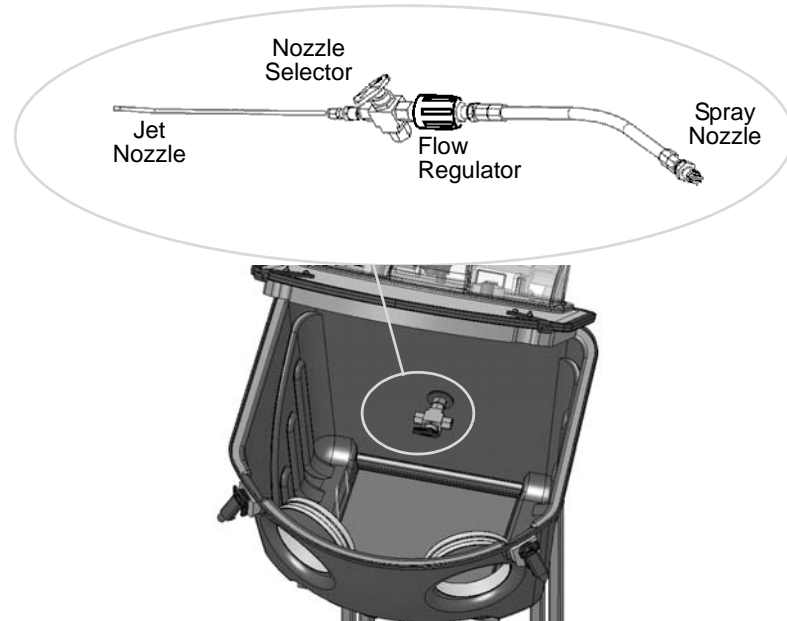

Figure 3-6: Nozzle selector valve

Foot Pedal

The foot pedal activates the water pressure pump.

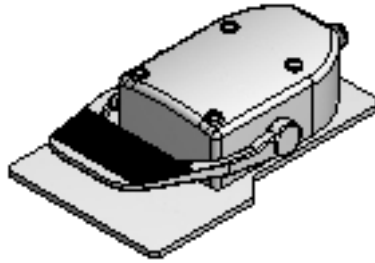

Figure 3-7: Foot pedal

Waste Filter

The support material removed during the cleaning process collects in the waste filter at the bottom of the WaterJet unit. Remove and clean the waste filter regularly, preferably after each model-cleaning session.

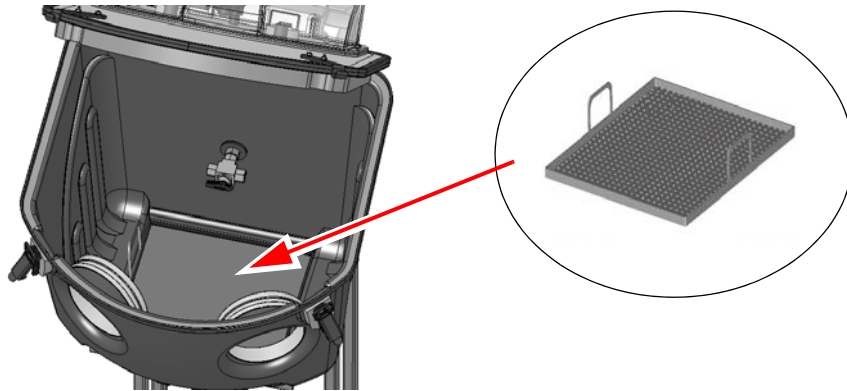

Figure 3-8: Waste filter

Water Inlet

The water enters the WaterJet unit through the water inlet. The high-pressure hose from the water pressure pump connects to the water inlet.

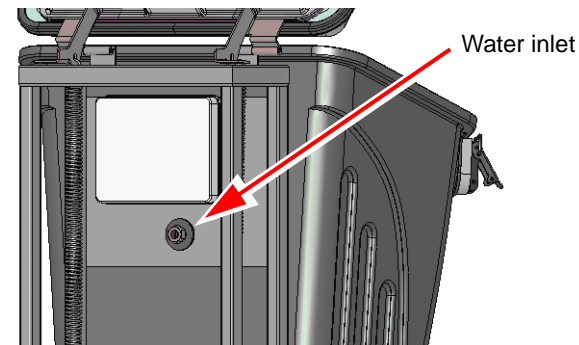

Figure 3-9: WaterJet inlet connection

4

Installation

Configuring the WaterJet Stand	4-2
Attaching the Feet to the Base	4-2
Assembling the Table Stand	4-3
Assembling the Floor Stand	4-4
Leveling the WaterJet Unit.....	4-6
WaterJet Connections.....	4-7
Connecting the Water Supply	4-7
Connecting the Drain Hose	4-9
Connecting the Power Cables.....	4-9

Configuring the WaterJet Stand

You can place the WaterJet unit on the floor or on a raised surface, such as a table or a counter.

Attaching the Feet to the Base

Before assembling the WaterJet stand, connect the four feet to the base of the stand (see figure 4-1).

To connect the feet to the base:

1. Prepare—
 - a 17 mm open-end wrench
 - four feet with nuts (supplied)
2. Fasten a nut on each of the WaterJet feet.
3. Insert the feet into the base, through the holes.
4. Secure each of the feet to the base with another nut.
5. Tighten the nuts.

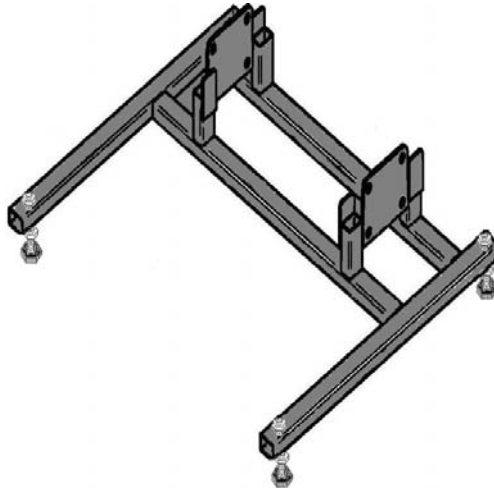

Figure 4-1: Attaching the WaterJet feet

Assembling the Table Stand

To assemble the stand for placing the WaterJet unit on a table or counter:

1. Prepare—
 - an M6 Allen key
 - a 13 mm open-end wrench
 - Eight (8) M8 Allen screws with nuts (supplied)
2. Place the WaterJet cabinet on the base (see figure 4-2).
Make sure the matching attachment plates (on the cabinet and base) are flush, and that the holes are aligned.

Note: There should be no space between the two plates.

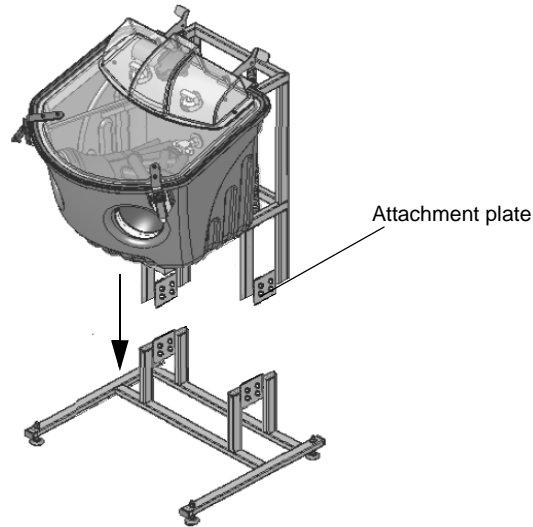

Figure 4-2: Assembling the stand for tables

3. Insert the Allen screws into the holes in the attachment plates and attach the nuts.
4. Tighten the screws and nuts, using the M6 Allen key and 13 mm open-end wrench.

Assembling the Floor Stand

To assemble the stand for placing the WaterJet unit directly on the floor:

1. Prepare—
 - an M6 Allen key
 - a 13 mm open-end wrench
 - 16 Allen screws and nuts (supplied).
2. Fit a stand extension onto the base (see figure 4-3).

Make sure the matching attachment plates (on the stand extension and base) are flush, and that the holes are aligned.

Note: There should be no space between the two plates.

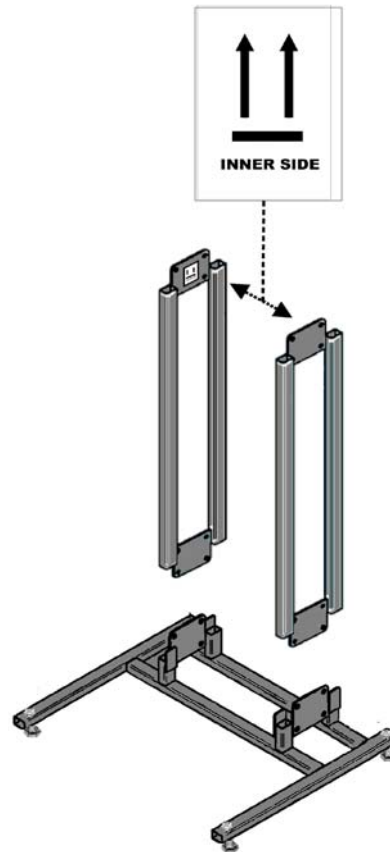

Figure 4-3: Attaching the stand extensions

3. Insert the Allen screws into the holes in the attachment plates and attach the nuts.
4. Tighten the screws and nuts, using the M6 Allen wrench and 13 mm open-end wrench.
5. Repeat steps 1-3 for the other stand extension.

6. Place the WaterJet cabinet on the stand extensions (see figure 4-4).
Make sure the matching attachment plates (on the WaterJet cabinet and stand extensions) are flush, and that the holes are aligned.
Note: There should be no space between the two plates.

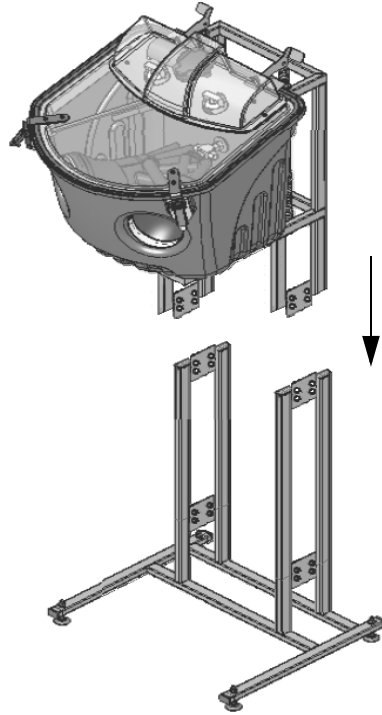

Figure 4-4: Attaching the WaterJet cabinet to the stand extensions

7. Insert the Allen screws into the holes in the attachment plates and attach the nuts.
8. Tighten the screws and nuts, using the M6 Allen wrench and 13 mm open-end wrench.

Leveling the WaterJet Unit

The WaterJet unit should be level, with all four feet resting securely on the floor or table.

To adjust the height of the feet:

1. Prepare—
 - a 17 mm open-end wrench
 - a spirit (bubble) level
2. Place the spirit level on the base of the WaterJet (front-to-back and left-to-right)
3. Loosen the nuts securing the feet at their current height (a).
4. Adjust the height of the feet (b).
5. Tighten the nuts so that the foot height is retained (c).

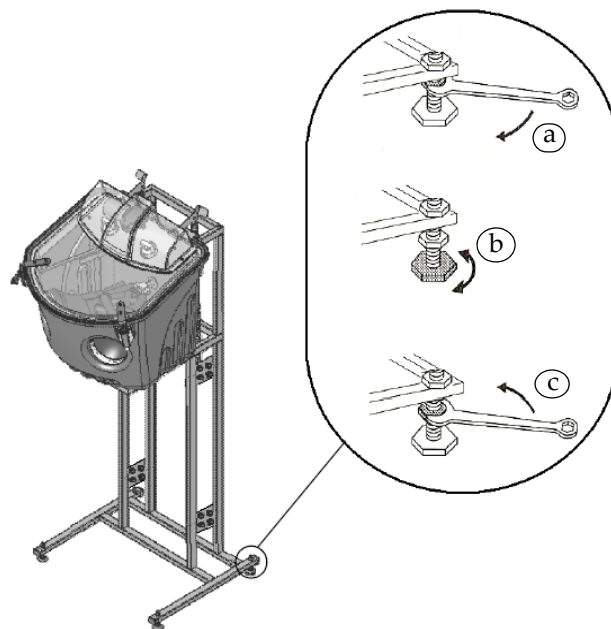

Figure 4-5: Leveling the WaterJet

WaterJet Connections

The following figure shows the WaterJet unit and the water pressure pump assembled and connected to the electrical and water supplies.

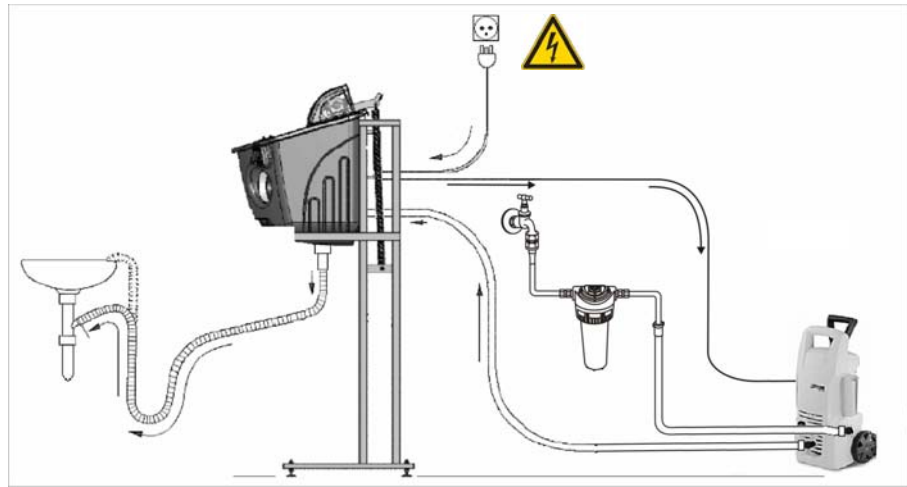

Figure 4-6: WaterJet connections

Connecting the Water Supply

To connect the water supply:

1. Prepare the following:
 - garden hose with hose adapters and hose clamps (supplied)
 - pressure hose (supplied)

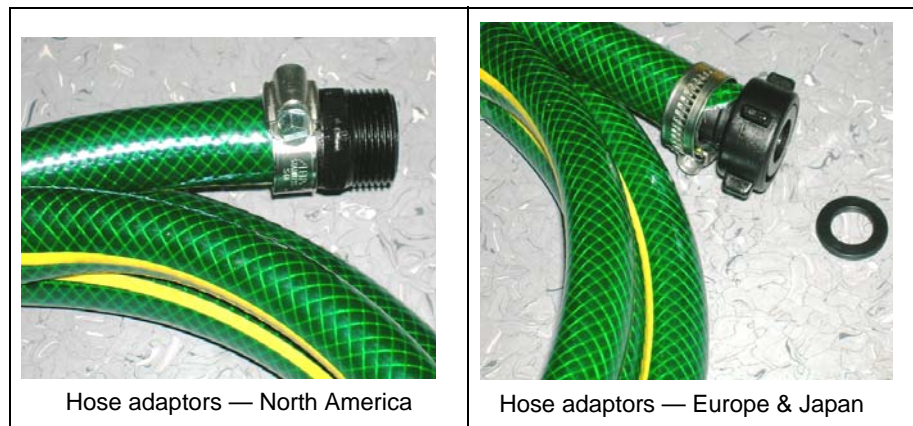

Figure 4-7: Garden hose inlet adapters

2. Connect the hose adapter on the garden hose to the inlet on the water pressure pump.

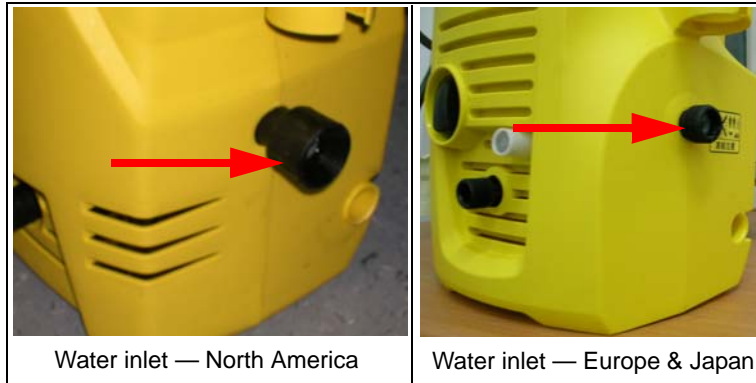

Figure 4-8: Water pressure pump inlets

3. Connect the other side of the garden hose to the filtered cold water tap.
4. Secure the hose to the water tap with a hose clamp.



CAUTION: Lack of water or insufficient water pressure may cause the pump to operate improperly, overheat, or fail. Read the instructions provided with the water pressure pump.

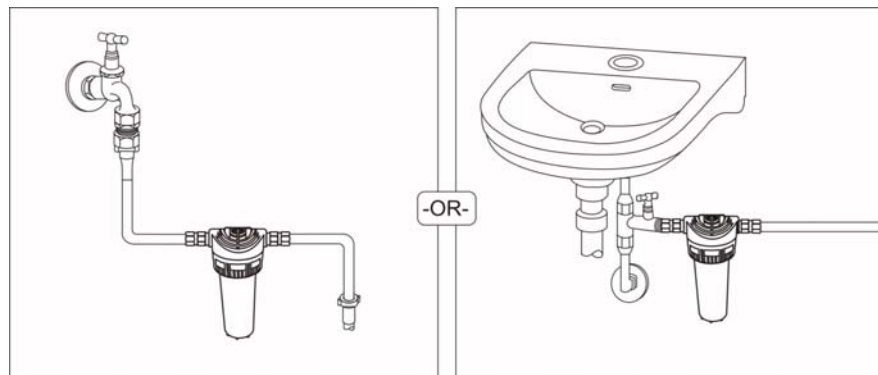

Figure 4-9: An example of the water supply connections

5. Connect the high pressure hose between the water outlet on the water pressure pump and the water inlet on the WaterJet unit.

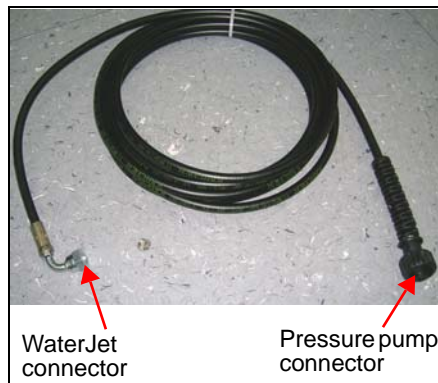

Figure 4-10: High pressure hose

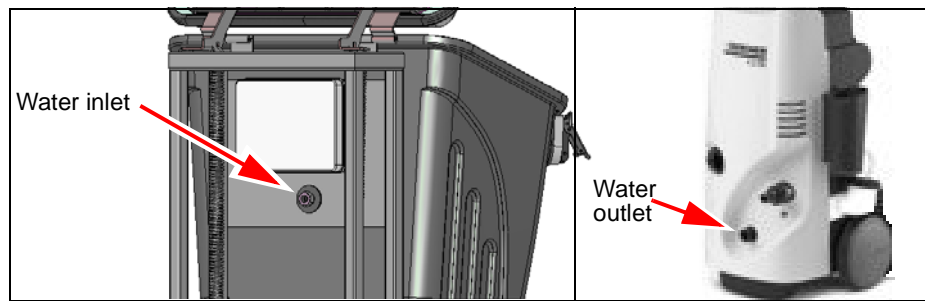

Figure 4-11: WaterJet inlet and pressure pump outlet

Connecting the Drain Hose

To connect the drain:

1. Connect the drain hose between the WaterJet outlet and the drain connection.
2. Insert the hose about 5 cm (2 in.) into the drain, to prevent the waste water from overflowing.

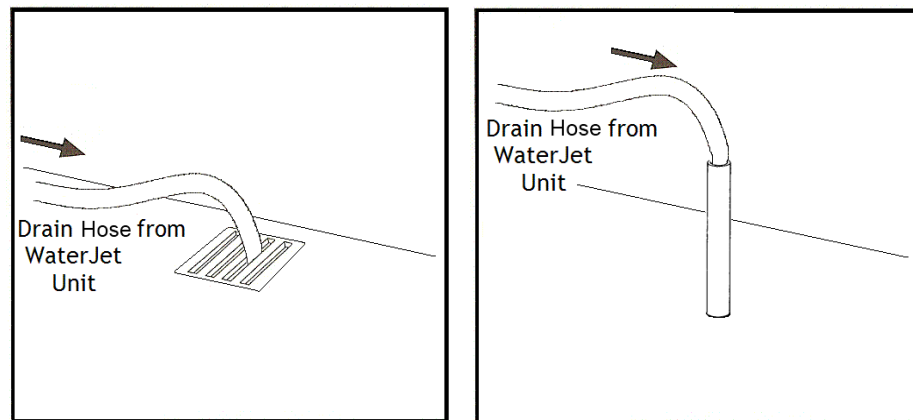

Figure 4-12: Drain options

Connecting the Power Cables

The water pressure pump is controlled with the WaterJet foot pedal, which is connected to the electric box on the back of the WaterJet unit at the factory. The pump's power cable connects to the electric box on the back of the WaterJet unit, as shown in figure 3-4 on page 3-6. The WaterJet unit connects to a wall outlet.



Do not change the power plug at the end of the water pressure pump power cable.

To connect the power cables:

1. Prepare the main power cable that connects the WaterJet unit to the wall outlet.
 - For Europe: an IEC 320 10A/100-230 V, C13 cable is supplied by the distributor or the customer.
 - For North America and Japan: the power cable is supplied with the WaterJet unit.



Figure 4-13: Power cable for North America and Japan



WARNING: Be sure the power cable is properly grounded, and that it can handle the electrical load of the WaterJet and the water pressure pump:

- 15 A for 100-volt system
- 15 A for 110–120-volt system
- 10 A for 220–240-volt system

2. Make sure the pressure pump is turned off.
3. Connect the cable from the water pressure pump to the universal power outlet at the back of the WaterJet unit (see figure 3-4 on page 3-6).



Always connect the water pressure pump power cable to the WaterJet unit.

4. Make sure the main power switch at the back of the WaterJet cabinet is turned off (see “On/Off Switch” on page 3-5).
5. Connect the main power cable between the IEC 320 C14 power outlet at the back of the WaterJet unit (see figure 3-4 on page 3-6) and the wall outlet.



WARNING: Electrical Hazard. Leakage currents could cause serious electrical shock. Make sure that the wall outlet conforms with the requirements specified in the Site Preparation Guide.

Cleaning Models

Cleaning Process.....	5-2
Removing Excess Support Material by Hand	5-2
Removing Support Material with the WaterJet	5-2
Jet Nozzle	5-2
Spray Nozzle.....	5-2
Operating the WaterJet	5-3
Removing Support Material with Sodium Hydroxide	5-4

Cleaning Process

The cleaning process consists of different methods, depending on the size of the model, how delicate it is, and the amount and location of the support material.

Use the following methods for cleaning models.

Removing Excess Support Material by Hand

While wearing protective gloves, break away the excess support material on the outside of the model. For delicate models, use a toothpick, pin or small brush after dipping the model in water.

Removing Support Material with the WaterJet

For most models, the most efficient way to remove support material is by using the high water pressure, using the jet or spray nozzles.

Jet Nozzle

Use the jet nozzle like a scalpel to cut and trim large support-structure areas. The jet nozzle provides higher water pressure and is suitable for:

- large models without thin walls or fragile sections
- clearing support material from cavities, pipes, tubes and cylinders



The jet nozzle is not suitable for cleaning models made from Tango printing materials. Using it could leave noticeable marks on the model.

Examples of models suitable for cleaning with the jet nozzle are: engine blocks and shoe soles.

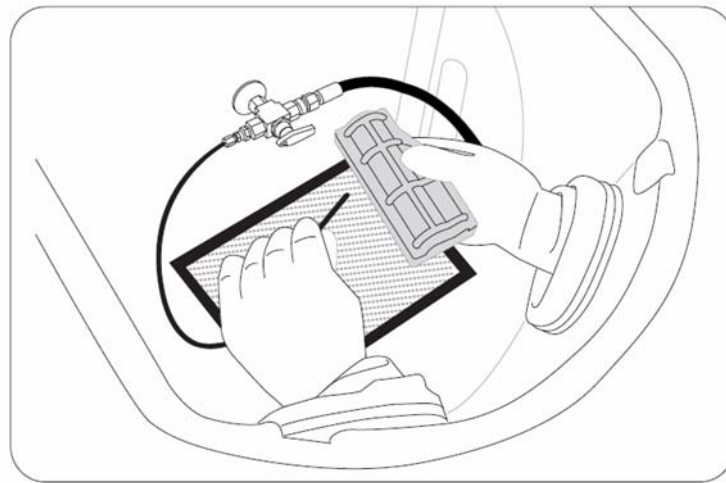

Figure 5-1: Model cleaning using the jet nozzle

Spray Nozzle

Use the spray nozzle for cleaning:

- delicate parts
- parts with thin walls or fragile areas
- models made from TangoBlack and TangoGray materials

Examples of models suitable for cleaning with the spray nozzle are: jewelry and dental appliances.

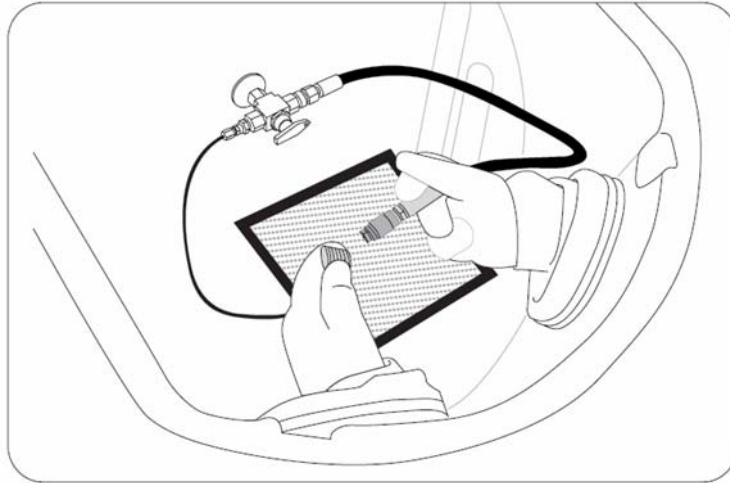

Figure 5-2: Model cleaning using the spray nozzle

Operating the WaterJet

To operate the WaterJet:

1. Open the water supply source to the water pressure pump.
2. Turn on the main power switch at the back of the WaterJet (see “On/Off Switch” on page 3-5).
3. Open the WaterJet unit cover.
4. Place a model in the WaterJet unit.
5. Close the cover and lock it with the latches (see “Cover Latches” on page 3-6).



WARNING:

- Do not continue until you make sure that you have closed and locked the WaterJet cover.
 - Wear earplugs for protection against loud noise.
6. Insert your hands in the built-in gloves in the WaterJet unit.
 7. Select a suitable cleaning nozzle (see “Nozzle Selection and Flow Regulation” on page 3-7).

8. Activate the WaterJet using the foot pedal (see “Foot Pedal” on page 3-8) and clean the model. If available, use the flow regulator to increase or decrease the flow.

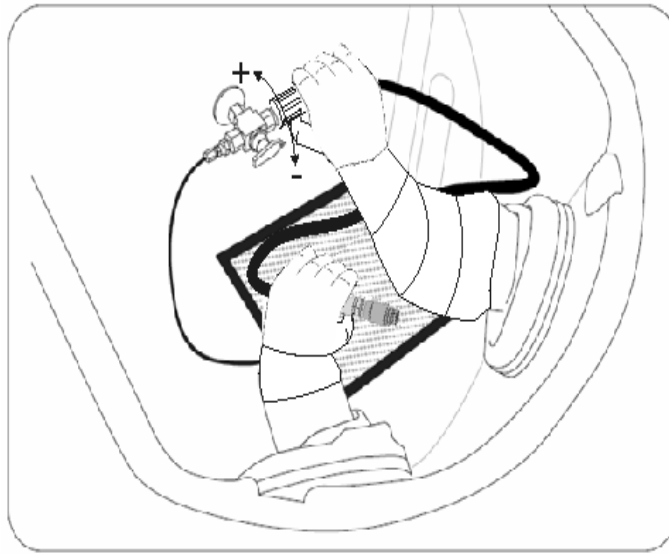

Figure 5-3: Using the Regulator

9. When you have finished removing the support material, open the WaterJet unit cover and remove the model.
10. When you have finished cleaning models, turn off the power to the WaterJet.
11. Turn off the water supply to the water pressure pump.
12. Empty the waste filter (see “Waste Filter” on page 3-8).



When the WaterJet is not in use:

- Keep the cover open. This allows the cabinet to dry and prevents corrosion of the wiper motor.
- **Always** turn off the water supply. This prevents leaks and damage to the water hose and connections.

Removing Support Material with Sodium Hydroxide

To remove thin layers of support material or from hard-to-reach areas and to give the model a smooth, clean finish, soak the model in a 2-percent solution of sodium hydroxide (NaOH, known as *caustic soda*).

The amount of time required to soak the model in the solution depends on how delicate it is and how much support material needs to be removed, but it is typically between half-an-hour and several hours. In any case, you should remove as much support material as possible before the treatment, and rinse the model thoroughly with the WaterJet afterwards.



WARNING: Caustic soda may cause chemical burns, scarring and blindness. Mixing it with water generates heat that could ignite other materials. Take adequate safety precautions; always use nitrile gloves when handling caustic soda and models soaked in it.

6

Maintenance

Replacing a Lamp.....	6-2
Replacing the Wiper Fuse	6-4
Maintaining the Water Pressure Pump.....	6-5

Replacing a Lamp

When a lamp inside the WaterJet cover fails, replace it with a standard 24 volt, 15-watt halogen lamp.



WARNING: Wait until the lamp has cooled before handling it.

To replace a lamp:

1. Make sure that the WaterJet is switched off.
2. Using a Phillips screwdriver, open the two locking nuts (see figure 6-1) and remove the protective cover.

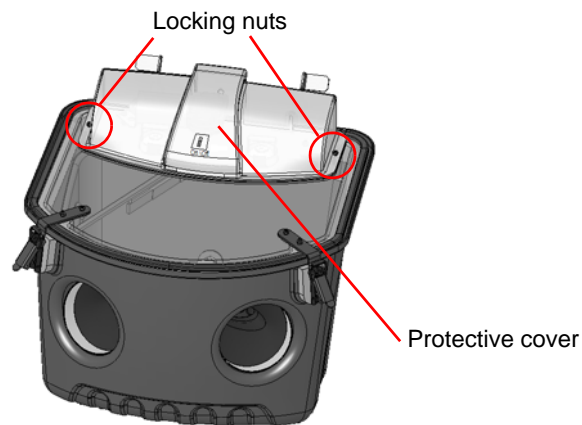

Figure 6-1: Removing the protective cover

3. Remove the lamp holder (see figure 6-2).

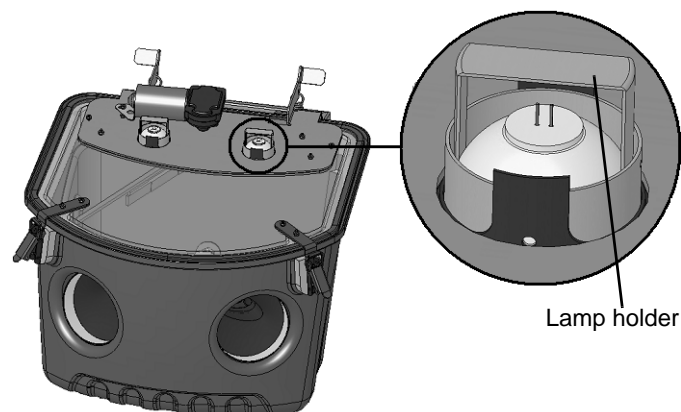

Figure 6-2: Lamp assembly (wires and connector).

4. Remove the metal band securing the lamp and carefully move the lamp out of the lamp assembly.
5. Pull the faulty lamp out of the socket to disconnect it from the wires.
6. Grasp the new lamp with its carton or a clean cloth, and insert it into the socket.



CAUTION: Do not touch the glass part of the new lamp with your fingers. Oil from your fingers can cause the lamp to explode or fail.

7. Place the lamp in the lamp assembly and attach the metal band.
8. Insert the lamp holder.
9. Attach the protective cover. (If necessary, push the locking screws up from under the WaterJet cover.)

Replacing the Wiper Fuse

When the wiper fuse fails, replace it with one that has the same rating (250 V/3.5 A/SB).

To replace the wiper fuse:

1. On the electrical box, turn off the power switch.
2. Disconnect the power cable plug from the wall socket, and place it on a dry surface.



WARNING: Electrical hazard. Handling the fuse while the cable is connected could result in injury. Do not continue to the next step until the WaterJet cable has been disconnected.

3. Carefully replace the existing fuse.
 - a. Using a flat head screwdriver, remove the fuse holder from the electrical box.
 - b. Remove the existing fuse from the fuse holder.
 - c. Check that the new fuse has the same rating (250 V/3.5 A/SB).
 - d. Insert the new fuse into the fuse holder.
 - e. Re-insert the fuse holder into the electrical box.

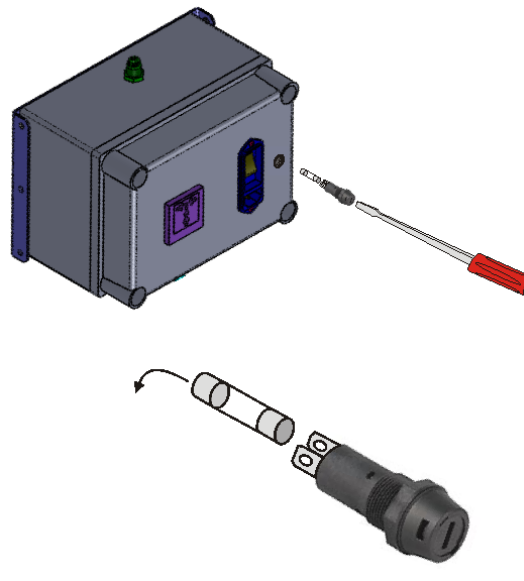

Figure 6-3: Replacing the Wiper Fuse

4. After making sure that the electrical plug is dry, insert it into its socket.
5. Turn on the power switch on the electrical box.
6. Activate the WaterJet and make sure that the wiper is functional.

Maintaining the Water Pressure Pump

Maintenance Perform the following maintenance checks at least once every six months.

Water Pressure

The water pressure supplied to the pump should be at least 1 atm, delivering 12 liters of water per minute. Pressure lower than this can damage the pump.



In case of low water pressure at the WaterJet, verify that the tap is open fully. If so, close the tap and check the water filter.

Water Leaks

Check the water pressure pump, water hoses, and their connections.

- If water leaks from a hose connection, open it and replace the O-ring.
- If a connector leaks, replace the thread-seal tape:
 1. Open the connector and remove the old thread-seal tape.
 2. Wrap fresh thread-seal tape (for example, *PTFE* or *Teflon*[®] tape) on the thread of the connector.
Wrap thread-seal tape clockwise, in the direction of the thread, so that it doesn't unwrap when tightening the connection.
 3. Close and tighten the connector.

Troubleshooting The following are some typical issues and suggested solutions.

The pump turns off every 10 to 15 seconds.

1. Detach the spray nozzle tip from the nozzle selector valve in the WaterJet and let the water run for about five minutes with the pump on.
This action removes air and dirt trapped in the water pressure pump and in the water supply hose.
2. Check that the nozzle tip is not blocked or damaged.
3. Reattach the spray nozzle tip.



A clogged nozzle can prevent the WaterJet from operating!

The pump stops working.

- Check the water pressure supplied at the pump. Low water pressure may cause the pump to overheat and stop.
The minimum required pressure at the pump is 1 atm.
A clogged water filter will reduce the water pressure to the pump.
- Check the main fuse and replace, if necessary.

7

WaterJet Replacement Parts

WaterJet Replacement Parts..... 7-2

WaterJet Replacement Parts

The following diagram shows most of the replaceable components in the WaterJet system.

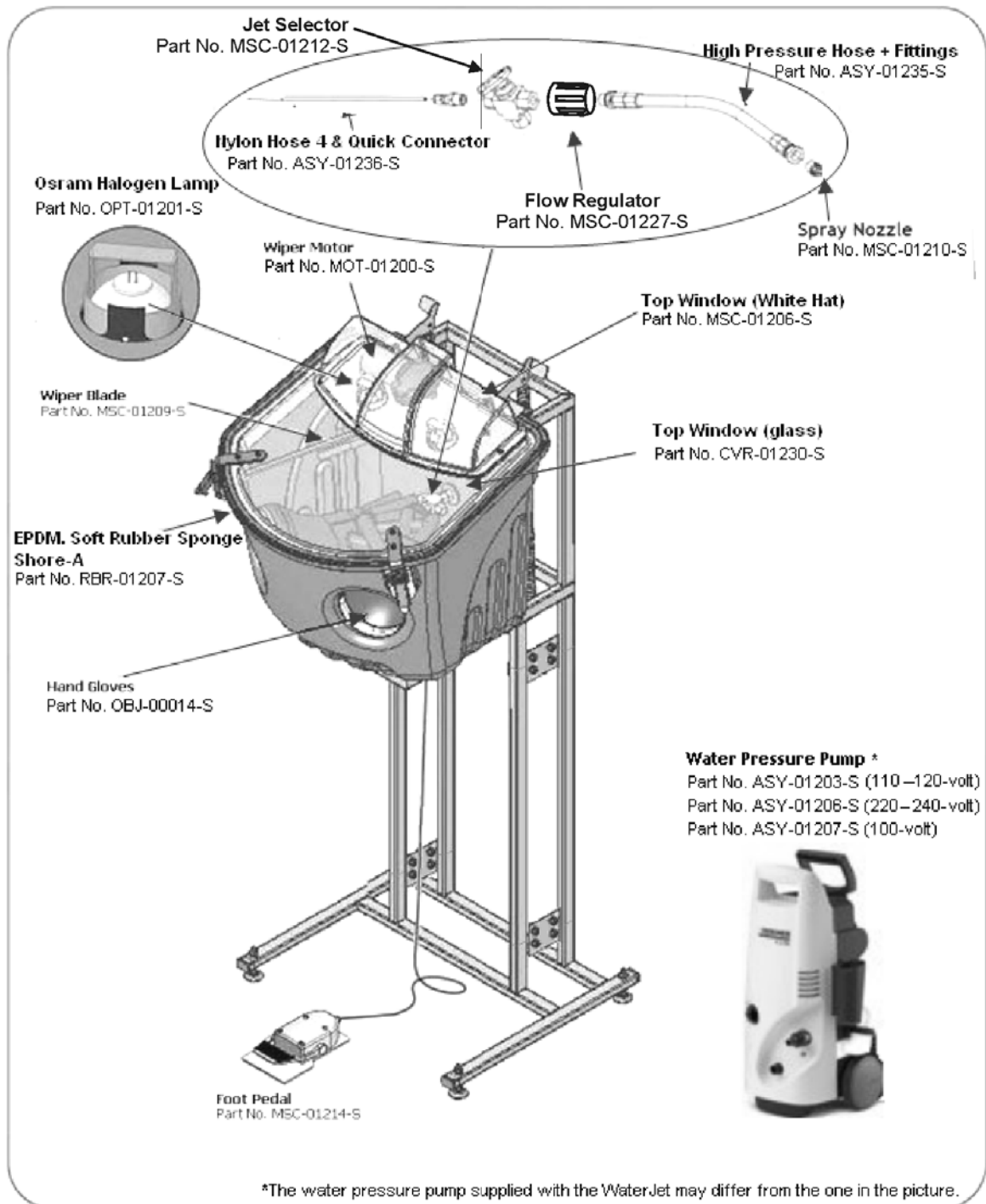

Figure 7-1: Objet WaterJet system and part numbers

The part number for all of the replaceable parts are listed in the table below.

Table 1: Spare parts for the Objet WaterJet

Description	Part Number (P/N)
Top window (White hat)	MSC-01206-S
Top window (glass)	CVR-01230-S
Wiper motor	MOT-01200-S
Wiper blade	MSC-01209-S
Osram halogen lamp	OPT-01201-S
220–240-volt electrical box	ASY-01227-S
100–120-volt electrical box	ASY-01226-S
100-volt electrical box	ASY-01225-S
EPDM soft rubber sponge (gasket)	RBR-01207-S
Hand gloves	OBJ-00014-S
Jet selector	MSC-01212-S
Nylon hose 4 & quick connector	ASY-01236-S
High pressure hose & fittings	ASY-01235-S
Spray nozzle	MSC-01210-S
Flow regulator	MSC-01227-S
Waste (mesh) filter	FLT-01200-S
Foot pedal	MSC-01214-S
Water pressure pump (100V)	ASY-01207-S
Water pressure pump (110-120V)	ASY-01203-S
Water pressure pump (220-240V)	ASY-01206-S

